

# PALERANG DEVELOPMENT CONTROL PLAN 2015



Document ID: 1780051

## Dates of Approvals & Commencement of this Development Control Plan

Date Approved by Council	Date Commenced	Description	Version
21 May 2015	27 May 2015	Development Control Plan (in full)	1
8 April 2020	29 April 2020	Amendment to Part E Notification	2
9 September 2020	14 November 2022	Amendment to reflect QPRLEP 2022, updated Tree and Vegetation section and inserted Character Statement for North Elmslea	3
27 October 2021	10 November 2021	Amndment and updates to re-adopt Heritage Controls of the Braidwood DCP, update Tree and Vegetation Controls and add Character Statement for North Elmslea New Residential Development Areas as well as updating outdated references.	4

## Table of Contents

<b>Part A Preliminary Information</b> .....	<b>6</b>
A1 About this Development Control Plan.....	6
A2 Citation - Name of this Development Control Plan .....	6
A3 Land covered by this Development Control Plan .....	6
A4 Purpose.....	7
A5 Structure of this Development Control Plan .....	7
A6 Variations to the Development Control Plan .....	8
A7 When to use this Development Control Plan .....	8
A8 Lodging a Development Application.....	9
A9 Notification of a Development Application.....	9
A10 Publication of Development Applications Received List.....	9
A11 Amendments, Modifications and Reviews .....	9
A12 Process Following Receipt of Submissions .....	10
A13 Developer Levies .....	10
A14 Relationship to Voluntary Planning Agreements .....	11
A15 Relationship to Other Council Policy Documents .....	11
A16 Savings and Transitional Provisions .....	11
A17 References to External standards and documents .....	11
A18 The Consent Authority .....	11
A19 Glossary .....	11
A20 Planning Framework.....	12
A21 Ecologically Sustainable Development.....	13
<b>Part B General Provisions</b> .....	<b>15</b>
B1 Site Analysis.....	15
B2 Accessible Design.....	16
B3 Flora, Fauna, Soil and Watercourses .....	20
B4 Bush Fire Prone Land.....	31
B5 Crime Prevention through Environmental Design .....	34
B6 Development on ridges and prominent hills and within 200 metres of a classified road .....	35
B7 Engineering Requirements .....	36
B8 Erosion and Sediment Control .....	53
B9 Flood Planning.....	57
B10 Heritage - European (non-Indigenous), Aboriginal (Indigenous) and Natural.....	59
B11 Social and economic impact assessment .....	74
B12 Landscaping .....	74
B13 On-site System of Sewage Management (OSSM).....	76
B14 Potentially contaminated land .....	82
B15 Waste management.....	83

B16	Greywater reuse .....	85
B17	Rainwater tanks .....	86
B18	Solid fuel heaters.....	88
B19	Sydney, Googong and Captains Flat drinking water catchments.....	89
<b>Part C Development Specific Provisions.....</b>		<b>90</b>
C1	Subdivision.....	90
C2	Residential development.....	101
C3	Affordable Housing.....	116
C4	Exhibition homes and villages .....	117
C5	Temporary residential accommodation .....	117
C6	Sheds, garages, carports and animal housing in residential and RU5 land use zones .....	118
C7	Business land development - B2 Local Centre and B4 Mixed Use.....	119
C8	Industrial development .....	123
C9	Restaurants or cafés in RU1 Primary Production or C4 Environmental Living.....	127
C10	Eco-tourist facilities .....	127
C11	Bed and Breakfast Accommodation .....	128
C12	Outdoor Dining .....	130
C13	Roadside Stalls .....	132
C14	Use of the footpath.....	133
C15	Swimming pools.....	135
C16	Shipping Containers.....	136
C17	Lighting .....	137
C18	Advertising signage .....	137
C19	Directional signage .....	143
C20	Events.....	145
C21	Caravan Parks and camping grounds (including primitive camping grounds).....	146
C22	Filling of land .....	147
C23	Demolition of buildings or structures.....	148
C24	Sheds in RU1 Primary Production, C3 Environmental Management and C4 Environmental Living .....	149
C25	Rural industry.....	150
C26	Intensive Agriculture .....	151
C27	Animal boarding or training establishments for cats, dogs and horses.....	152
C28	Horse stables and horse arenas .....	155
C29	Gates and Fencing.....	157
<b>Part D Area Specific Provisions.....</b>		<b>159</b>
D1	Bungendore .....	159
D2	Braidwood.....	166
D3	Villages.....	168
D4	Mt Gillamatong.....	172

D5	Lots 1 and 2 DP 456367, Lot 2 DP 131294 and Lot 1 DP 1067259 .....	173
D6	North Elmslea New Residential Development Areas Identified for Residential Growth under the Bungendore Structure Plan 2048 .....	174
<b>Part E Notification of Development Applications.....</b>		<b>175</b>
<b>Appendices.....</b>		<b>176</b>

## Part A Preliminary Information

### A1 About this Development Control Plan

The *Queanbeyan-Palerang Regional Local Environmental Plan 2022 (QPRLEP2022)* provides the statutory framework for land use management in the Queanbeyan-Palerang Local Government Area (LGA), subject to overriding planning controls in State Environmental Planning Policies and legislation.

This development control plan (DCP) expands on the aims, objectives and other provisions of the *QPRLEP2022* and provides detailed development provisions for development in the former Palerang LGA.

The purpose of a DCP is to provide guidance to developers and the consent authority when carrying out or approving development to:

- Achieve the objectives of land use zones under an environmental planning instrument (EPI); and
- Facilitate permissible development under an EPI.

Provisions in a DCP are therefore to provide guidance and are not statutory requirements.

### A2 Citation - Name of this Development Control Plan

This DCP is called the Palerang Development Control Plan 2015. It has been prepared pursuant to the provisions of Section 3.6 of the *Environmental Planning and Assessment Act 1979* and Clauses 16-24 of the *Environmental Planning and Assessment Regulation 2000*.

Queanbeyan-Palerang Regional Council ('Council'), as the consent authority, is required under Section 4.15 of the *Environmental Planning and Assessment Act 1979* to take into consideration the relevant provisions of the DCP in determining development applications on land to which it applies.

### A3 Land covered by this Development Control Plan

The DCP applies to all land in the former Palerang local government area except for the state conservation area 'Braidwood and its setting'. Controls relating to 'Braidwood and its setting' are contained in the *Braidwood Development Control Plan 2006*.

The adoption of this DCP repeals the following development control plans:

- Palerang Council, Fencing Requirements in Rural, Environmental Protection and Rural Residential Areas
- Cooma-Monaro DCP No. 1 Development and Subdivision of Land (Urban and Rural)
- Cooma-Monaro Development Control Plan No. 20 Exempt Development
- Cooma-Monaro Development Control Plan No. 21 Complying Development
- Mulwaree Development Control Plan No. 6 Rural Subdivision for Dwelling Houses
- Mulwaree Development Control Plan No. 5 Dwelling Houses and Class 10 Buildings
- Palerang Council Development Control Plan Advertising and Notifying Development Applications
- Palerang Council, Palerang Advertising Signs Development Control Plan 2007
- Palerang Council, Palerang Activities in Public Places Development Control Plan 2007
- Palerang Council, Development Control Plan Yarrowlumla LEP 2002 2(v) Village Zone
- Yarrowlumla Development Control Plan Rural Zones
- Yarrowlumla Development Control 7(e) Environmental Protection Zone
- Tallaganda Environmental Heritage Development Control Plan No. 1

- Tallaganda Development Control Plan No. 3. Rural Small Holding Development
- Tallaganda Development Control Plan No. 6 Exempt Development
- Tallaganda Development Control Plan No. 7 Complying Development
- Tallaganda Shire Council, Development Control Plan No. 8 On-Site Sewage Management
- Tallaganda Shire Council, Development Control Plan No. 4 Rural 1(a)

## A4 Purpose

The purpose of this DCP is to provide more detailed provisions and to support the aims of the *QPRLEP2022*. The aims of the *QPRLEP2022* are:

- a) to protect and promote the use and development of land for arts and cultural activity, including music and other performance arts,
- b) to protect and improve the economic, environmental, social and cultural resources and prospects of the community,
- c) to facilitate the orderly and economic use and development of land having regard to ecological sustainability principles,
- d) to provide for a diversity of housing to meet the needs of the community into the future,
- e) to provide for a hierarchy of retail, commercial and industrial land uses that encourage economic and business development that caters for the retail, commercial and service needs of the community,
- f) to keep and protect important natural habitat and biodiversity,
- g) to protect water quality, aquifers and waterways,
- h) to keep, protect and encourage sustainable primary industry and associated commerce in rural areas,
- i) to identify and protect the cultural heritage of the area, including the built heritage and the Aboriginal heritage,
- j) to protect important scenic quality, views and vistas,
- k) to facilitate the orderly growth of urban release areas,
- l) to ensure development does not unreasonably increase the demand for public services or public facilities,
- m) to identify, protect and provide areas for community health and recreational activities.

## A5 Structure of this Development Control Plan

This DCP is comprised of four parts. It is important to read all parts as development applications must respond to all relevant matters in the DCP.

### Part A – Preliminary Information

This part contains the preliminary information associated with the DCP and an explanation as to how it should be used. It also sets out the planning framework for the DCP.

### Part B – General Provisions

This part contains the General Provisions that apply to all development. These provisions include:

- Site Analysis
- Biodiversity
- Bush fire prone land
- Contaminated land
- Crime prevention through environmental design

- Disability standards for access
- Engineering requirements (roads, parking, stormwater management, water and utilities)
- Erosion and sediment control
- Flood planning
- Heritage
- Landscaping
- On-site system of sewage management
- Tree and vegetation preservation
- Waste management

## Part C – Development Specific Provisions

This part contains the development specific provisions and includes:

- Subdivision
- Rural development
- Residential development
- Business development
- Industrial development
- Specific land uses

## Part D – Area Specific Provisions

This part contains area-based provisions. Where an area-based provision is inconsistent with a general provision or a development specific provision, the area-based provision prevails to the extent of that inconsistency.

## Part E – Notification of a Development Application

This part contains provisions to ensure that public participation occurs in an orderly, consistent and transparent manner.

# A6 Variations to the Development Control Plan

Provisions of a DCP are intended to provide guidance and are not statutory requirements. Council may consider varying the development provisions where it can be demonstrated that the objectives to which the provision relates can be wholly achieved by an alternative solution and the proposal is consistent with the *QPRLEP2022* aims and zone objectives.

A variation that is inconsistent with any local environmental plan aim or zone objective will not be supported.

# A7 When to use this Development Control Plan

This DCP applies to all development that requires consent in the former Palerang local government area except for the state conservation area of 'Braidwood and its setting' where the *Braidwood DCP 2006* applies.



## A8 Lodging a Development Application

### Pre-lodgement meetings

Applicants are encouraged to seek advice from Council prior to lodging a development application by contacting Council's customer service staff to arrange a pre-lodgement meeting.

### Standard development application requirements

The *Environmental Planning and Assessment Act 1979* and the associated regulations specify the documentation required with all development applications. Missing or incomplete documentation can delay processing the development application. Checklists setting out the required information for different types of development are available from Council's customer service staff or on Council's website [www.qprc.nsw.gov.au](http://www.qprc.nsw.gov.au)

## A9 Notification of a Development Application

Public participation is an important component of the development assessment process. To ensure that public participation occurs in an orderly, consistent and transparent manner the development application will be advertised or notified in accordance with Part E.

## A10 Publication of Development Applications Received List

A list of development applications received will be published on Council's website.

## A11 Amendments, Modifications and Reviews

### Amended applications – prior to determination

In accordance with the Environmental Planning and Assessment Regulation 2000, a development application may be amended or varied by the applicant (but only with the agreement of the consent authority) at any time before the development application is determined.

When a development application is amended, prior to it being determined, the development application may be readvertised and re-notified in accordance with Part E.

### Modification of development consents - Section 4.55 applications

The *Environmental Planning and Assessment Act 1979* allows the modification of development consents where the consent authority is satisfied that following the modification the development will be substantially the same development as the development that was originally approved.

There are 3 categories of Section 4.55 applications:

- Section 4.55(1) – modifications involving minor error, misdescription or miscalculation
- Section 4.55(1A) – modification involving minimal environmental impact
- Section 4.55(2) – other modifications

The application may be readvertised and re-notified in accordance with Part E.

### Request for review of determinations – Section 8.2 review

In accordance with the *Environmental Planning and Assessment Act 1979*, an applicant may request that Council review a determination of an application, other than:

- a) a determination to issue or refuse to issue a complying development certificate, or
- b) a determination in respect of designated development, or

- c) a determination in respect of integrated development, or
- d) a determination made by the council under Division 4.6 in respect of an application by the Crown.

## A12 Process Following Receipt of Submissions

Submissions in relation to development applications, Section 4.55 applications and Section 8.2 applications must be in writing (email is acceptable).

Submissions received by the Council will be available for public inspection upon request under the *Government Information (Public Access) Act 2009*. Submissions will not be kept confidential, and the names and details of submitters will not be suppressed, but details will not be included in Council business papers and will not be published on Council's website.

The Council will acknowledge submissions in writing.

If a development application is to be considered at a Council meeting, those who made written submissions, together with the applicant, will be advised of the Council meeting date at which the development application is to be considered. Applicants and submitters will have the opportunity to make a short statement at the Council meeting.

Those who made submissions will be advised in writing of the Council's decision regarding the development application.

## A13 Developer Levies

Development contributions are levies applied to certain development as a means to fund local infrastructure and services that are required as a result of new development. The contributions are levied under the provisions of Section 7.11 and Section 7.12 Local Infrastructure Contribution Plans prepared pursuant to the *Environmental Planning and Assessment Act 1979* and Section 64 of the *NSW Local Government Act 1993*.

The following Development Contributions Plans apply to the Palerang local government area:

- Palerang Section 94A Development Contribution Plan
- Bungendore Section 7.11 Development Contributions Plan for Community and Recreation Facilities 2022
- Bungendore Section 7.11 Contributions Plan No. 8 - Provision of Pathway Network at Bungendore
- Bungendore Section 7.11 Contributions Plan No. 9 - Street upgrading at Bungendore
- Palerang Section 94 Plan No. 10 - Provision of Kings Highway Culverts at South Bungendore
- Bungendore Section 7.11 Development Contributions Plan for Car Parking Facilities 2021
- Yarrowlumla Section 94 Plan No. 2 - Provision of Access Roads
- Yarrowlumla Section 94 Plan No. 3 - Provision of Community Facilities
- Tallaganda Section 94 Plan No. 3 - Roadworks
- Tallaganda Section 94 Plan No. 4 - Bushfire Control and Suppression
- Mulwaree Section 94 Plan - 2003-2008

Section 7.11 and 7.12 contributions are determined in conjunction with a Development Application and are imposed by a condition of consent in accordance with the development contributions plan in force at that time. Contribution rates are adjusted quarterly in line with the Consumer Price Index or as specified in the individual plans.

Generally development applications for subdivision, dual occupancy, secondary dwelling, multi dwelling housing, residential flat buildings, seniors housing, commercial and industrial development, as well as

development applications for dwelling houses on lots that were not created by an approved subdivision, will be subject to development contributions.

Contributions are usually satisfied by payment of a monetary contribution. However, subject to Council approval, contributions can also be satisfied by dedication of land and material public benefit (works-in-kind) or a combination of these.

The Act also provides for the negotiation of development contributions via a Voluntary Planning Agreement between Council and a developer.

The following Section 64 plans apply to the Palerang local government area:

- Water Supply - Development Servicing Plan for former Palerang
- Sewerage - Development Servicing Plan for former Palerang

## A14 Relationship to Voluntary Planning Agreements

The consent authority is required to take into consideration, where relevant, a planning agreement that has been entered into under Section 7.4 of the *Environmental Planning and Assessment Act 1979*, or any draft planning agreement that a developer has offered to enter into under Section 7.4.

## A15 Relationship to Other Council Policy Documents

This DCP should be read in conjunction with the *QPRLEP2022*.

Certain development may be subject to other policies of Council. The onus is on any prospective applicant to check with Council if there are any additional or updated documents relevant to the site that require consideration when making a development application.

## A16 Savings and Transitional Provisions

This DCP does not apply to any development application, any application to modify development consent under Section 4.55 of the *Environmental Planning and Assessment Act 1979* Act, or any application for a review of determination under Section 8.2 of the *Environmental Planning and Assessment Act 1979*, which was lodged with Queanbeyan-Palerang Regional Council, but not finally determined before the commencement of this DCP. Any development application lodged before the commencement of this DCP will be assessed in accordance with any previous DCP, or other Council policy which applied at the time of development application lodgement.

## A17 References to External standards and documents

References are made in this DCP to external documents and standards, including but not limited to Australian and New Zealand Standards, AUSPEC specifications and standard drawings. In all circumstances, the reference is taken to mean the current version of that standard or specification.

## A18 The Consent Authority

Queanbeyan-Palerang Regional Council is the consent authority for most development applications. The Minister is the consent authority for projects identified as being of state significance and the Joint Regional Planning Panel may be the consent authority for development of regional significance.

## A19 Glossary

This DCP adopts the terms and definitions of the *QPRLEP2022*. Additional terms used in this DCP are defined below:

## Arterial road

Arterial road are roads that carry high volumes of traffic and provide key transport links but are not classified roads

## Buffer

Land set aside for the purpose of separating land areas where uses are incompatible, for example industry and housing.

## Building articulation

Building articulation refers to the manner in which the building surfaces, edges, corners and materials unit to form the building. Elements of articulation include treatment to porches, balconies, doors, windows, roofs, materials and other architectural details. In highly articulated buildings each part clearly stands out.

## Building envelope

The building envelope illustrates in a document such as an instrument made under the *NSW Conveyancing Act 1919*, the area where buildings can be erected.

## Classified road

Classified road are roads designated by NSW Roads and Maritime Services as important transport links. The classified roads in the Queanbeyan-Palerang local government area are the Federal Highway, Monaro Highway, Kings Highway, Cooma Road, Sutton Road, Nerriga Road, Goulburn Road, Tarago Road, Macs Reef Road, Captains Flat Road and Bungendore Road (refer to map in Appendix D).

## Development application

An application which seeks consent to carry out development and includes details of the proposed development and its impacts.

## Easement

An easement is a restriction on the use of land. The width, location and purpose of an easement is shown on the Deposited Plan.

## Public domain

Urban space which can be accessed by the public. It may include footpaths, roads and different types of park. In some instances the area is used for passive or non-passive recreation.

# A20 Planning Framework

## NSW Environmental Planning and Assessment Act 1979

Planning and development is carried out under the NSW *Environmental Planning and Assessment Act 1979* and the NSW Environmental Planning and Assessment Regulation 2000.

## State Environmental Planning Policies

State Environmental Planning Policies are made under the NSW *Environmental Planning and Assessment Act 1979*. They are environmental planning instruments and are developed where policy extends beyond a local area. For example the State Environmental Planning Policy (Biodiversity and Conservation) 2021 manages water quality in the Sydney drinking water catchment. A large part of the Queanbeyan-Palerang local government area is within the Sydney drinking water catchment. There are numerous State Environmental Planning Policies applying to the local government area.

## The Queanbeyan-Palerang Regional Local Environmental Plan 2022

The *QPRLEP2022* has been prepared for the Queanbeyan-Palerang local government area in accordance with the *Standard Instrument (Local Environmental Plans) Order 2006*.

The local environmental plan consists of a text document and maps. The aims of the local environmental plan are contained in the first part and each of the land use zones has a set of objectives.

The objectives are taken into account when a development application is being determined. It is not necessary to meet every objective. However, a development application that meets several is likely to be favourably considered.

It should be noted that the objectives are not strategies which require either property owners or Council to undertake work.

## Exempt and Complying Development

The *Environmental Planning and Assessment Act 1979* provides that, as long as specified requirements are satisfied, certain developments can be:

- Exempt development, this type of development can proceed without any approvals under the *Environmental Planning and Assessment Act 1979*
- Complying development, this type of development can proceed with a streamlined approval process under the *Environmental Planning and Assessment Act 1979*

Provisions relating to exempt and complying development are contained primarily in the *State Environmental Planning Policy (Exempt and Complying Development Codes) 2008*, with some additional provisions in the *QPRLEP2022*.

Exempt and complying development is still subject to any approvals or other requirements under other legislation such as the *Local Government Act 1993*, *Roads Act 1993* and *Water Management Act 2000*. This includes approvals for driveways across nature strips, water and sewer connections and stormwater discharge.

## A21 Ecologically Sustainable Development

Ecologically Sustainable Development means using, conserving and enhancing natural resources so that the ecological processes on which life depends are maintained, and the total quality of life, now and in the future, is improved. A key concept of sustainable development is that social, economic and environmental considerations are interdependent.

Ecologically sustainable development policies have been adopted by governments at all levels across Australia and the principles have been included in a range of legislation. One of the objectives of the *Environment and Planning Assessment Act 1979* is to encourage ecologically sustainable development.

The *Local Government Act 1993* Dictionary defines the principles of ecologically sustainable development as those set out below. Principles are rules of conduct or action that are applied when implementing a policy or making decisions. They provide guidance on how decisions should be made.

### Principles of ecologically sustainable development

Ecologically sustainable development requires the effective integration of economic and environmental considerations in decision-making processes. Ecologically sustainable development can be achieved through the implementation of the following principles:

- a) The precautionary principle—namely, that if there are threats of serious or irreversible environmental damage, lack of full scientific certainty should not be used as a reason for postponing measures to prevent environmental degradation.

In the application of the precautionary principle, public and private decisions should be guided by:

- i. Careful evaluation to avoid, wherever practicable, serious or irreversible damage to the environment, and
  - ii. An assessment of the risk-weighted consequences of various options
- b) Inter-generational equity—namely, that the present generation should ensure that the health, diversity and productivity of the environment is maintained or enhanced for the benefit of future generations

- c) Conservation of biological diversity and ecological integrity—namely, that conservation of biological diversity and ecological integrity should be a fundamental consideration,
- d) Improved valuation, pricing and incentive mechanisms—namely, that environmental factors should be included in the valuation of assets and services, including the following:
  - i. Polluter pays—that is, those who generate pollution and waste should bear the cost of containment, avoidance or abatement.
  - ii. The users of goods and services should pay prices based on the full life cycle of costs of providing goods and services, including the use of natural resources and assets and the ultimate disposal of any waste.
  - iii. Environmental goals, having been established, should be pursued in the most cost effective way, by establishing incentive structures, including market mechanisms, that enable those best placed to maximise benefits or minimise costs to develop their own solutions and responses to environmental problems.

Examples of addressing the principles of Ecologically Sustainable Development in a new development might include the:

- use of solar or wind power
- planting of a xeriscape garden instead of using exotic plants
- use of a conservation agreement to protect an area of high biodiversity
- total cost of the development, for example a private recreation facility, is borne by those who will benefit from the development. This could be through the charging of an entry fee which covers all operational costs and provides funds for maintenance and ongoing improvements
- provision of walkways and shaded outdoor areas
- development is located close to a reasonable level of community services and infrastructure, or
- reuse of an older building
- water re-use and water sensitive urban design

The *Local Government Act 1993* requires Council to take account of Ecologically Sustainable Development in all decision making, including its assessment of any development proposal. Additionally, the *NSW Land and Environment Court* has found that the principles of Ecologically Sustainable Development are to be considered.

The principles should also be taken into account by applicants in establishing project objectives, site selection and in the project layout, design, technology and operational decisions.

## Part B General Provisions

### B1 Site Analysis

A site analysis is required to ensure that development is of a high quality, minimises environmental impacts and positively contributes to the existing character of the locality.

The site analysis should comprise of a site plan and accompanying written material. The site plan is to illustrate the existing site attributes and constraints and must be based on a survey drawing produced by a qualified surveyor and contain a reference number and a date. Where no Deposit Plan is available distances shall be provided from natural features such as a river. In some instances an identification survey may be required

Unless otherwise agreed in writing by Council at a pre-lodgement meeting, a site analysis is required for all development applications.

#### Objective

- a) To ensure that site attributes and constraints are carefully considered in the site planning and assessment process

#### Development application requirements

- Plans of the proposed development at a scale that shows the detail of the proposed development
- A due diligence assessment for Aboriginal heritage. Refer to section B10.2 Aboriginal Heritage in this DCP
- An A3 sized site plan is required for all development at a scale that allows it to be easily read. The following scales are provided as a guide:
  - 1:100 to 1:200 within a village area
  - 1:500 to 1:2000 for rural residential/rural development
  - 1:1000 for a road.
  - north point and bar scale

**Note:** Development on large lots may require lodgement of more than one site plan, each at different scales to allow all the site attributes and constraints to be read.

The plan is to show the following:

- microclimate including the prevailing winds
- lot dimensions, fences, boundaries and any easements
- existing contours at 0.25m intervals and levels to Australian Height Datum (AHD). Where development is proposed on land that has a slope of less than 2%, contour intervals are to be at 0.2m intervals. Development applications should show contours that are appropriate to the topography and nature of the proposed development
- steeply sloping land in excess of 18 degrees (unsuitable for house construction) – Note the *QPRLEP2022* Landscape Map shows slopes over 18 degrees and clause 7.7 of the *QPRLEP2022* requires that proposed development on these areas receive additional consideration
- existing cadastral boundaries and all adjoining Crown land (including Crown Public roads) must be identified
- flood affected areas (refer to section B.9 Flood planning in this DCP)
- overland stormwater flow paths, drainage and services

- any potentially contaminating land uses that have occurred on the land, contaminated soils or filled area or unstable lands (refer to section B.14 Potentially contaminated land in this DCP)
- easements or connections for drainage and internal house drains, water, sewer and utility services
- Identification of any existing trees or significant vegetation, including remnant vegetation, native grasses, improved pasture, habitat corridors and habitat for threatened species (refer to section B3 Flora, fauna, soil and watercourses)
- any existing buildings and other structures, including their setback distances from the existing or proposed lot boundaries
- heritage features (refer to sections B.10 Heritage – European (non-Indigenous), Aboriginal (Indigenous) and Natural and D Area Specific Provisions in this DCP)
- existing and proposed road network, including connectivity and access for all adjoining land parcels (refer to section B.7 Engineering requirements in this DCP)
- pedestrian and vehicle access (refer section B.7 Engineering requirements in this DCP)
- views to and from the site, including prominent ridgelines visible from surrounding areas and dedicated public roads (refer to section B.6 Development on ridgelines and prominent hills in this DCP)
- overshadowing by neighbouring structures
- any other notable features or characteristics of the site
- adjoining land uses
- sources of noise
- information required by other sections of this DCP. For example details relating to the proposed On-site System of Sewage Management (refer to B13).

## B2 Accessible Design

### B2.1 Access

The way in which buildings are designed can result in discrimination in places of employment, tourist or other accommodation, offices, or places of entertainment, recreation and leisure. The *Disability Discrimination Act 1992* makes it unlawful to discriminate on the grounds of disability in providing access to or use of premises that the public can enter or use.

Walkways, ramps and landings, handrails, grab rails, doorways, doors and door circulation space, entertainment facilities, signs, car parking, sanitary facilities, washbasins, washroom fixtures and fittings, showers and floor surfaces are all areas where accessibility requires consideration.

### B2.2 Premises standards

The *Disability (Access to Premises – Buildings) Standards [Premises Standards]* requires any new building open to the public, or existing buildings undergoing renovation, to comply with the standards.

The *Premises Standards* apply to certain classes of buildings and structures governed by the *Building Code of Australia* that require building approval for a construction certificate or complying development certificate where the application is for the:

- erection of a building
- alterations and additions to an existing building, or
- an application for a change in building use where building works are proposed or required to meet fire safety standards.

The *Premises Standards* also introduce a new concept referred to as an ‘affected part’ of an existing building. This means the principal pedestrian entrance to the building and any part of the building that



is necessary to provide a continuous accessible path of travel from the principal pedestrian entrance to the new or upgraded part of the building.

Table 1 summarises the *Building Code of Australia* classes of building to which the *Premises Standards* apply. This Table should be read in conjunction with the *Premises Standards* for more detailed requirements, including exemptions.

The lodgement of a development application does not in itself trigger the *Premises Standards*. However, it should be considered at this stage to reduce the need to modify any consent issued through a Section 4.57 application at the construction certificate stage so as to comply with the *Premises Standards* requirements.

Table 1 Class of building and the premises standards

Building Class	Building Type	Premises Standards that can apply
Specified Class 1b	Premises (not exceeding 300m <sup>2</sup> and maximum of 12 persons) providing short term holiday accommodation such as bed & breakfast, farm stay, holiday cabin, tourist park, hostel and boarding house.	Access required to and into specified common areas and proportion of rooms or cabin.
Class 2	Residential flat building common areas where one or more sole occupancy units are made available for short term rent as holiday units, serviced apartments or time-share facilities.	For new buildings access is required to specified common areas and at least one floor containing sole occupancy units up to the entrance doorway of every sole occupancy unit on that level.
Class 3	Hotel, motel or a larger boarding house or hostel (that is not a class 1 or class 2 building), residential parts of schools or universities, specialist accommodation for people with a disability and residential parts of detention centres.	Access provided through a pedestrian entrance to at least one floor containing sole occupancy units and to the doorway of each unit. Access to be provided to at least one of each type of common room or space. Minimum ratio of accessible sole occupancy units specified.
Class 5, 6, 7b, 8 & 9a	Includes schools, universities, early childhood centres theatres, cinemas, sports stadiums and concert halls	Access required by any person using the building, to all areas within the building normally used by the occupants Small Class 5, 6, 7b and 8 buildings may qualify for exemptions regarding access to upper floors.
Class 7a	Car park	Continuous accessible path of travel must be provided from any building required to be accessible to any level of an associated car park containing accessible car parking spaces.
Class 9b	Includes schools, universities, early childhood centres theatres, cinemas, sports stadiums and concert halls	Access must be provided to all areas normally used by the occupants. In larger class 9b buildings wheelchair seating must be provided in locations representative of fixed-seating locations taking into account amenity, proximity to facilities, available sight lines and pricing. Class 9b transport facilities are subject to additional requirements.
Class 9c	Aged care buildings	Access provided through a pedestrian entrance to at least one floor containing sole occupancy units and to the doorway of each unit. Access to be provided to at least one of each type of common room or space. Ratio of accessible sole occupancy units specified.

Class 10a	Non-habitable building including private garage, carport, shed, toilet block, change room or the like..	Certain class 10a buildings are require to be accessible if they are located in an accessible area, eg, a toilet block in a park, a change room associated with a sports field or a structure used to provide shelter.
Class 10b	Structure including wall, fence, swimming pool and the like	Health centre pools, public pool or a common-use pool associated with class 3 buildings and has a perimeter measured at the water's edge of more than 40m requires at least one form of access for people with a disability.

## Objective

- a) To ensure that the public domain of new developments provides equitable and safe access.

## Control

- 1) An access report detailing how the proposed development will meet the *Premises Standards* and *Building Code of Australia* will be required with the development application.
- 2) Access is to be compliant with the *Disability Discrimination Act 1992* where it is not covered by the Premises Standards.

## B2.3 Adaptable Housing

Across Australia almost 1 in 5 persons have a disability. As people age this ratio increases to around 1 in 2 persons for those aged over 60 years (ABS 2009). There is an increasing need for dwellings that can be lived in by people with a disability, but also dwellings that can be easily adapted to meet the changing needs of occupants across their lifetime. Adaptable housing provides for the flexible design of a dwelling, which has the potential to meet, a broad range of housing needs (for example older people and those with a disability) as it can be modified to cater for a range of occupants or visitors whose circumstances may change over time.

### Liveable housing design guidelines

Liveable housing design means designing homes to meet the changing needs of occupants across their lifetime. A liveable home is designed to be:

- easy to enter
- easy to move around in
- capable of easy and cost effective adaptation
- designed to respond to the changing needs of the home occupants

*Liveable Housing design guidelines (National Dialogue on Universal Housing Design 2011)* provide information on how to introduce liveable design features into a new home or applied within existing homes. Reference is also made to *AS1428.1 - 2009 Design for Access and Mobility* and *AS4299 - 1995 Adaptable Housing*.

### Australian Standard AS4299 – 1995 Adaptable Housing

In addition to being designed to be usable by most people, a house built to *AS4299-1995* has provision for additional modifications, should they be required, to meet the specific needs of an occupant. This may include the modification of kitchen joinery to meet changing physical needs, alterations to the laundry and bathroom to increase access and usability, the increase of lighting levels in response to sensory disability or the introduction of support devices such as grab rails and or additional security measures.

The objectives of *AS4299-1995* are to ensure that adaptable dwellings generally meet the following performance requirements:

- To be visitable by people who use wheelchairs, including at least one wheelchair accessible entry and a path of travel to the living area and to an accessible or visitable toilet.

- To have no steps and a minimum of level changes.
- To enable manoeuvrability for wheelchairs in and between the living area, kitchen, bedroom, bathroom and toilet.
- To provide ease of reach to electrical controls, taps, shelves and cupboards at levels to suit people who use wheelchairs.
- To provide laundry facilities capable of adaptation to enable access by people who use wheelchairs (can be external to the housing unit providing there is a wheelchair accessible path of travel).
- To prevent the establishment of small spot fires within the structure.
- To protect the structure from the external environment by providing adequate protective space around the structure.

The Standard contains both normative and informative components. Appendix A of the Standard comprises a checklist of 119 design and performance features for adaptable housing units which are classified as essential (55), first priority desirable (41), and desirable (23).

Plans and construction of adaptable housing units can be independently certified to this checklist as follows:

- adaptable house class A: all essential and desirable features incorporated,
- adaptable house class B: all essential and a minimum 50% of desirable features (including all those notated first priority) incorporated, or
- adaptable house class C: all essential features incorporated.

## Objective

- To encourage the introduction of livable housing design elements to single dwellings and dual occupancy development to meet the changing needs of occupants across their lifetime.
- To increase the stock of dwellings which meet the Class B *Adaptable Housing Australian Standard AS4299-1995*.

## Control

- Single dwellings, secondary dwellings, dual occupancy and semi-detached dwellings are to consider incorporating, as a minimum, the following six core design elements in the design of the building:
  - a safe and continuous path of travel from the street entrance and/or car parking area to the dwelling entrance that is level,
  - at least one level (step free) entrance into the dwelling,
  - internal doors and corridors that facilitate comfortable and unimpeded movement between spaces,
  - a toilet on the ground (or entry) level that provides easy access,
  - a bathroom that contains a hobless (step free) shower recess, and
  - reinforced walls around the toilet, shower and bath to support the safe installation of grab rails at a later date.
- Where a development will contain three or more dwellings, a minimum of one third of the dwellings are to meet the Class B requirements of *Australian Standard AS4299-1995 Adaptable Housing*.

## References

- Australian Human Rights Commission ([www.humanrights.gov.au](http://www.humanrights.gov.au))
- Australian Standards
  - AS4299-1995 Adaptable Housing*

- ii. *AS1428.1-2009 Design for Access and Mobility*
- Disability (Access to Premises – Buildings) Standards 2010, at [www.legislation.gov.au/Details/F2010L00668](http://www.legislation.gov.au/Details/F2010L00668)
- National Dialogue on Universal Housing Design, Revision1, (2011) Liveable Housing Design Guidelines at the Department of Families, Housing, Community Services and Indigenous Affairs <https://www.dss.gov.au/our-responsibilities/disability-and-carers/program-services/government-international/national-disability-strategy-initiatives/livable-housing-design/national-dialogue-on-universal-housing-design-strategic-plan>

## B3 Flora, Fauna, Soil and Watercourses

The management of assets such as native flora and fauna, soil and watercourses is important as they are the key to ensuring quality air and water and high levels of biodiversity which in turn means lower levels of pest and weed species and productive soils which provide opportunities for agriculture. The *QPRLEP2022* contains clauses relating to terrestrial biodiversity, soil erosion and salinity, and watercourses. Additionally, there is State (and in some instances Commonwealth) legislation relating to each of these. Before commencing any works that involve the disturbance of these assets it is necessary to check what approvals are required.

### B3.1 Terrestrial Biodiversity

The Queanbeyan-Palerang local government area, including in some instances the outer parts of urban areas, contains a wide range of terrestrial and aquatic threatened species (which are listed as being either critically endangered, endangered or vulnerable) and endangered ecological communities. Ecological communities are defined as a group of species that are found in the same land area. The *Biodiversity Conservation Act 2016* defines as ‘Threatened Ecological Community’ as a critically endangered ecological community, an endangered ecological community or a vulnerable listed in Schedule 2 of the Act.

Threatened ecological communities and species are required to be considered as part of the development assessment process. The threatened ecological communities and threatened species are listed in Schedule 1 and 2 of the *Biodiversity Conservation Act 2016*.

In some instances a proposal to remove trees or vegetation may require approval from government agencies that administer these acts in addition to Council.

#### Managing the conservation of biodiversity in relation to development

Currently there are a range of strategies to manage the conservation of biodiversity in relation to development. Options include Property Vegetation Plans, biodiversity offsets, biobanking and conservation agreements.

#### Further information

- Heritage NSW at [www.heritage.nsw.gov.au](http://www.heritage.nsw.gov.au)
- NSW Department of Planning and Environment at [www.planning.nsw.gov.au](http://www.planning.nsw.gov.au)
- NSW Local Land Services at [www.lls.nsw.gov.au](http://www.lls.nsw.gov.au)

The *QPRLEP2022* contains a Terrestrial Biodiversity map and clause 7.2 Terrestrial Biodiversity. The map shows the vegetation that has been determined as being of high conservation value, and thus, the areas to which clause 7.2 applies. However, as the map is at a large scale and only includes native vegetation known to be of conservation value, there may be some areas which are not shown. Therefore all areas that are proposed to be subject to development require at least preliminary consideration of biodiversity values. The level of consideration will depend on the type of development and its location.

## Objective

- a) To maintain and enhance the Queanbeyan-Palerang local government area's biodiversity
- b) To encourage the recovery of threatened species and endangered ecological communities
- c) To ensure that a report contains sufficient information to enable Council to determine the impact of the development proposal on biodiversity

## Control

- 1) The *QPRLEP2022* Terrestrial Biodiversity Map and clause 7.2 Terrestrial Biodiversity should be considered in the preparation of a development application. If the lot (or part of the lot) to be developed are shown on the Terrestrial Biodiversity Map, the development application must demonstrate how clause 7.2 has been addressed.
- 2) In the consideration of native flora and fauna, if the lot (or part of the lot) to be developed is shown on the Terrestrial Biodiversity Map, a landscape/habitat approach is to be taken in the assessment of whether threatened species or an endangered ecological community is present. This means that rather than focusing on records of flora and fauna species, the type of vegetation community present is to be the basis of the assessment. The type of vegetation present will determine the fauna species that may be present. For example if the vegetation community is identified as being Natural Temperate Grassland then it is possible that threatened native reptile species will be present or if there are mature trees, it is likely that native birds will use the area.
- 3) In some instances it will be necessary to have a native flora and fauna report prepared as part of the development application. Developments that commonly require a flora and fauna report includes subdivision and earthworks in rural and environmental zones. Council's requirements for flora and fauna reports are listed below. It is strongly recommended that prior to commencing the report, that the development application and the need for the report be discussed with Council and that the relevant NSW Government agency guidelines are consulted.
- 4) Terrestrial flora and fauna reports are to be prepared by a person experienced and qualified in the terrestrial native flora and fauna of the former Palerang local government area.

Note: Where aquatic species may be impacted, an aquatic ecologist should be consulted as part of the survey and report preparation.

The terrestrial flora and fauna report is to contain the following information:

- the qualifications and experience of the person undertaking the flora and fauna survey and writing of the report
- a map of the survey area (include the scale). Note: surveys are to include all areas associated with the proposed development, for example entrances, powerline routes, internal roads and areas of affected road reserve
- the date and time of the survey and the survey method (the guidelines published by the NSW Department of Planning and Environment are to be taken into account)
- a list of flora and fauna species identified in the survey
- a search of the NSW Wildlife Atlas and other government data bases
- the impact of the development proposal on native flora and fauna
- recommendations in relation to habitat corridors. Refer to section B3.4 habitat corridors in this DCP
- comments in regard to the corridor significance of the survey area
- seven part tests on any threatened species or endangered ecological communities
- mitigation measures
- species for planting

- recommended biodiversity conservation strategies (if these are to be used). Refer to the control below. The requirement for these strategies should be discussed with Council.
- 5) The integrity of remnant vegetation areas and corridors is to be preserved and enhanced where possible through strategies that may include fencing or supplementary planting – refer to section B3.4 Habitat Corridors in this DCP
- 6) Vegetation on ridge lines should not, unless absolutely necessary, be removed. Refer to section B6 Development on ridges and prominent hills of this DCP
- 7) Where native vegetation is to be removed, strategies to compensate for the clearing may be required. Strategies might include the legal preservation of the same vegetation type either on the land to be developed or other areas of the property or in the region. It should be noted that the planting of tube stock where mature trees are proposed to be removed is not considered an appropriate compensation strategy. The proposed strategy is to be included with the development application.

### Further information

- NSW Department of Planning and Environment at [www.environment.nsw.gov.au](http://www.environment.nsw.gov.au)

## B3.2 Soils and steep slopes

Some types of development can have an impact on accelerating erosion and sedimentation on steep land or on land with fragile and dispersible soils. These areas pose considerable challenges for the construction of buildings and infrastructure such as roads. Development in areas subject to impeded drainage, waterlogging or salinity should also be carefully examined to ensure expensive intervention strategies are not required in the future and damage to infrastructure does not occur.

The *QPRLEP2022* contains clauses 7.5 Salinity, 7.6 Highly erodible soils and 7.7 Slopes over 18 degrees and an associated Landscape Map. In some instances it will be necessary to have a report prepared as part of a development application.

### Objective

- a) To ensure that a report contains sufficient information to enable Council to determine the impact of the development proposal on the land

### Control

- 1) The *QPRLEP2022* Landscape map and clauses 7.5 Salinity, 7.6 Highly erodible soils and 7.7 Slopes over 18 degrees should be considered in the preparation of a development application
- 2) If it is considered that the areas shown on the Landscape map will not be impacted by the development this is to be demonstrated in the development application. If the development proposal will have an impact on an area on the Landscape map, a report will be required. The report is to contain the following information and is to be submitted with the development application:
  - the qualifications and experience of the person undertaking the survey and writing of the report. The person undertaking the report should have a strong background in soil science
  - a map of the survey area (include the scale)
  - the date and time of the survey and the survey method
  - a description of the soils and drainage of the area
  - a list of flora species in the development area
  - the impact of the development proposal on the area
  - mitigation measures
  - species for planting.

## Further information

- NSW Local Land Services at [www.lls.nsw.gov.au](http://www.lls.nsw.gov.au)
- NSW Department of Planning and Environment at [www.environment.nsw.gov.au](http://www.environment.nsw.gov.au)

## B3.3 Watercourses

Riparian areas provide an important transition area between aquatic and terrestrial environments. They provide bank stabilisation which reduces the loss of sediment into watercourses and habitat for aquatic and terrestrial fauna species.

Clause 7.4 Riparian land and watercourses of the *QPRLEP2022* and the associated map Riparian Lands and Watercourses contains provisions relating to development in riparian areas and watercourses.

Work proposed to be undertaken in a riparian area or watercourse may also require approval under the *Water Management Act 2000* and the *Fisheries Management Act 1994*.

In some instances it will be necessary to have a report prepared as part of the development application.

### Objective

- a) To ensure that a report contains sufficient information to enable Council to determine the impact of the development proposal on the land.

### Control

- 1) If it is considered that the areas shown on the Riparian Lands and Watercourse Map will not be impacted by the development, this is to be demonstrated in the development application. If the development proposal will have an impact on an area shown on the Riparian Lands and Watercourse, a report will be required. The report is to contain the following information and is to be submitted with the development application:
  - the qualifications and experience of the person undertaking the survey and writing of the report. Note: Where aquatic species may be impacted an aquatic ecologist should be consulted as part of the survey and report preparation
  - a map of the survey area (include the scale)
  - the date and time of the survey and the survey method
  - a description of the soils and drainage of the area
  - a list of flora and fauna species in the area
  - the impact of the development proposal on the area
  - mitigation measures
  - species for planting.

## Further information

- NSW Department of Primary Industries at [www.dpi.nsw.gov.au](http://www.dpi.nsw.gov.au)
- NSW Department of Industry - Water at [www.dpie.nsw.gov.au/water](http://www.dpie.nsw.gov.au/water)

## B3.4 Habitat corridors

A habitat corridor is an area of land (the size and shape varies) which allows for the movement of native flora and fauna. Areas of native flora allow native fauna species to move to a range of areas so that they can source food and breeding partners (the more potential breeding partners the more the potential for genetic diversity is increased).

Both of these are important in ensuring the health of the species, particularly when climate change is causing the location of flora and fauna species to change.

The movement may be either through terrestrial or aquatic environments or by flight. Different species will require different size habitat corridors. The retention of areas of native vegetation (including grasses) will provide the opportunity for habitat corridors to be maintained.

The planting of native vegetation particularly to link patches of native vegetation, may over time increase the size of the corridor. In landscapes that have been disturbed (such as land cleared for agriculture and housing) the retention and creation of links is crucial if native species are to remain in the area.

Buffer areas around patches of native vegetation can improve the condition of a patch. Buffers may include areas where grazing is reduced or native trees have been planted.

Strategies to maintain or enhance areas that contribute to a corridor include:

- avoiding clearing or cultivating on or around patches of native vegetation. During construction these areas should be fenced off
- retaining logs and leaf litter during the construction phase of development and beyond
- revegetating existing remnants and cleared areas with native species that are indigenous to the area
- controlling noxious and environmental weeds prior to the commencement of construction and once development is completed

In assessing a development application, the NSW *Environmental Planning and Assessment Act 1979* requires the consideration of the impact of the proposed development on native flora and fauna. Refer to section B3.1 Terrestrial biodiversity in this DCP.

## Objective

- a) To maintain or enhance habitat corridors

## Control

- 1) Developments that involve large amounts of land, for example wind or solar farms or subdivisions undertaken under the following *Queanbeyan-Palerang Regional Local Environmental Plan (QPRLEP) 2022* clauses (listed below), may require a habitat corridor management plan that will maintain or enhance existing habitat corridors

4.1	Minimum subdivision lot size (in rural and environmental zones)
4.1AA	Minimum subdivision lot size for community title schemes
4.1D	Subdivision of certain land in Zones RU1 and C3
4.1E	Subdivision of land in Zones C3 and C4

- 2) The habitat corridor management plan is to contain the following information:
  - a map illustrating the existing native vegetation on the property and habitat corridors in the region
  - the species that will be planted and the proposed location
  - proposed strategies other than planting, for example fencing, which will maintain or enhance habitat corridors
  - the timing of the proposed strategies

## Further information

- NSW Local Land Services at [www.lls.nsw.gov.au](http://www.lls.nsw.gov.au)
- NSW Department of Planning, Industry and Environment at [www.environment.nsw.gov.au](http://www.environment.nsw.gov.au)



## B3.5 Tree and Vegetation Management

The purpose of this Section is to declare trees and other vegetation under Part 2.2 of the *State Environmental Planning Policy (Biodiversity and Conservation) 2021*. Where a tree or other vegetation is declared in this Section, a person must not clear vegetation without a permit granted by Council (Clause 2.10 of the *State Environmental Planning Policy (Biodiversity and Conservation) 2021*).

This Section provides controls in respect of the preservation of trees and other vegetation. It outlines the circumstances in which trees and other vegetation can be removed without a permit, and those circumstances where a permit is required from Council. It is relevant to both the assessment of development applications, and applications for permits to remove vegetation where required.

Relevant clauses of the *QPRLEP2022* that also need to be considered in respect of the management of vegetation are:

- Clause 5.10 - Heritage Conservation
- Clause 7.2 - Terrestrial Biodiversity
- Clause 7.4 - Riparian Land and Watercourses
- Clause 7.14 - Scenic Protection

Various community land Plans of Management are referenced in this document with regard to maintenance of vegetation on public land. More detailed information for particular sites can be found on the Community Land Plans of Management section of Council's website.

Other sections of this DCP also deal with vegetation in certain circumstances, and these should also be referred to. These include:

- Part B3.4 - Habitat Corridors
- Part B10 - Heritage
- Part C1.3 - Specific requirements for land uses zones

### B3.5.1 Relationship to Other Legislation and Controls

The *Biodiversity Conservation Act 2016* is the overarching legislation governing the management of native vegetation in NSW. Any proposed activity or development that includes the removal of any native vegetation must be undertaken consistent with that legislation as well as the provisions set out in this plan.

The clearing of any native vegetation on land zoned RU1 Primary Production, RU2 Rural Landscape, RU3 Forestry or RU4 Primary Production Small Lots is wholly regulated by NSW Local Land Services under the *Biodiversity Conservation Act 2016*. Accordingly Council has no role in managing any clearing proposed in rural zones and any such proposals should be discussed with the relevant Local Land Services office.

*State Environmental Planning Policy (Biodiversity and Conservation) 2021* is also relevant to the management of both native and non-native vegetation in non-rural areas (ie, all zones with the exception of land zoned RU1, RU2, RU3 and RU4). Any clearing of trees and vegetation in these non-rural zones that is below the thresholds set out in the *Biodiversity Conservation Act 2016*, is primarily regulated by Council. Any removal or pruning of trees and vegetation in these circumstances requires a permit from Council, unless it falls within the exemptions identified elsewhere in this Section.

The Commonwealth Government also administers the *Environment Protection and Biodiversity Conservation Act 1999* which also provides controls for the protection of various native fauna and flora and which may also be relevant to any proposals to remove or damage native vegetation.

Note: Anyone proposing to pick, prune, damage or remove any native vegetation should ensure they discuss any proposals with the relevant State and Commonwealth Government agencies to confirm any other legal requirements in addition to the controls set out in this DCP.

### B3.5.2 Objectives

- 1) To declare trees and other vegetation under Part 2 of State Environmental Planning Policy (Biodiversity and Conservation) 2021,
- 2) To protect significant trees and vegetation from inappropriate removal to enhance the amenity, streetscape and ecological values of land subject to *QPRLEP2022*,
- 3) To preserve existing biodiversity values where possible through the preservation of trees and other vegetation that contribute to these values,
- 4) To minimise the loss of trees and other vegetation that contribute to the scenic character of the LGA,
- 5) To provide suitable criteria for the assessment of development applications,
- 6) To provide appropriate controls for the management of trees and vegetation consistent with State Environmental Planning Policy (Biodiversity and Conservation) 2021, and
- 7) To outline circumstances where the clearing of trees or other vegetation do and do not require a permit from Council.

### B3.5.3 Land to Which this Section Applies

This Section applies to the removal or pruning of vegetation that is less than the biodiversity offsets scheme threshold on non-rural land (land in any zone other than RU1 Primary Production, RU2 Rural Landscape, RU3 Forestry or RU4 Primary Production Small Lots) subject to *QPRLEP2022*.

**Note:** The proposed removal or pruning exceeds the biodiversity offsets scheme threshold if it is:

- the clearing of native vegetation of an area that exceeds the threshold (see Table 1 below), or
- the clearing of native vegetation is on land mapped as ‘Sensitive Values’ on the Biodiversity Values Map prepared by the NSW Department of Planning and Environment and located on their website.

If the proposed removal or pruning exceeds the biodiversity offsets scheme threshold, it requires an approval from the Native Vegetation Panel (refer to Part 2.14 of the *State Environmental Planning Policy (Biodiversity and Conservation) 2021*).

Table 1 - Thresholds for Clearing by Property Size

Minimum lot size associated with the property	Threshold for clearing, above which the BAM and offsets scheme apply
Less than 1 ha	0.25 hectares or more
1 ha to less than 40 ha	0.5 hectares or more
40 ha to less than 1000 ha	1 hectares or more
1000 ha or more	2 hectares or more

The minimum lot size applicable to any land being cleared is as follows:

- the minimum lot size as shown on the *QPRLEP2022* Lot Size Map, or
- if the Lot Size Map does not map a minimum lot size for the land, the actual size of that allotment of land on which the proposed development is to be carried out.

Figure 1 - Vegetation Clearing Procedure – Summary Chart

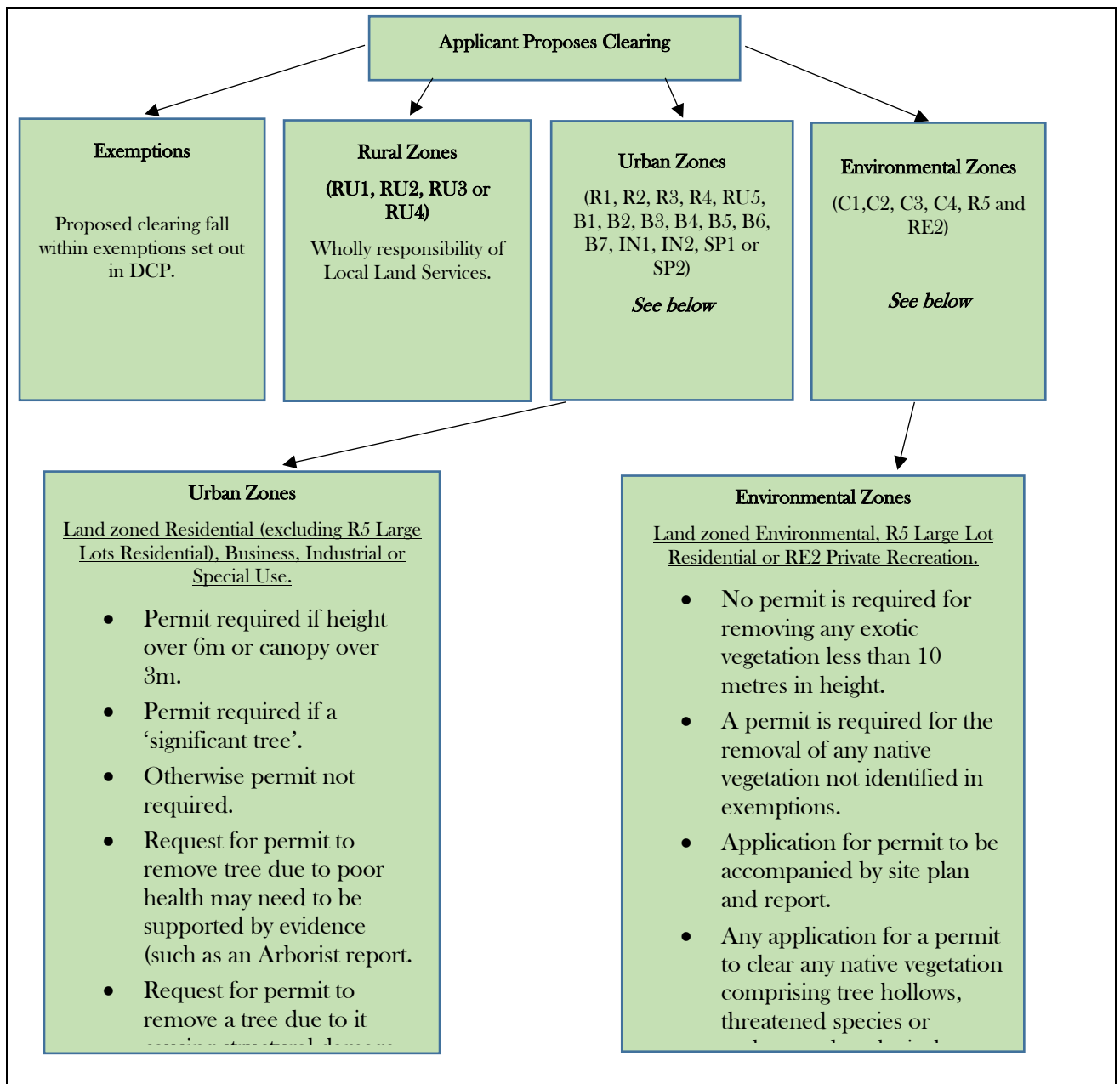

### 3.5.4 Exemptions

#### Exclusions from Exemptions

##### Environmental Heritage including Aboriginal Heritage

None of the exemptions listed in this Section apply to any trees or other vegetation located on a heritage item, Aboriginal object, Aboriginal place of heritage significance, or on land within a heritage conservation area.

Council can only grant a permit for the removal or pruning of vegetation on land that is, or forms part of a heritage item; or is within a heritage conservation area; or that is or forms part of an Aboriginal object; or is within an Aboriginal place of heritage significance, if it is:

- of a minor nature; or
- is for the maintenance of the heritage item, Aboriginal object, Aboriginal place of heritage significance, or heritage conservation area, and would not adversely affect the heritage

significance of the heritage item, Aboriginal object, Aboriginal place of heritage significance, or heritage conservation area.

As per clause 5.10(3) of the *QPRLEP 2020*.

Therefore, Council requires:

- a) a permit application for any removal or pruning of vegetation that is minor in nature or is for the maintenance of the heritage item, Aboriginal object, Aboriginal place of heritage significance, or heritage conservation area, and
- b) a development application for any other removal or pruning of vegetation on a heritage item, Aboriginal object, Aboriginal place of heritage significance, or on land within a heritage conservation area.

Clause 2.8 of *State Environmental Planning Policy (Biodiversity and Conservation) 2021* and Clause 5.10 of *QPRLEP2022* contain specific requirements for trees and other vegetation located on heritage items and heritage conservation areas and should be read in conjunction with this Section.

#### *Consent Conditions and 88B Instruments*

None of the exemptions listed in this Section apply to any trees or vegetation that are required to be retained by the conditions of a development consent or a Section 88B restriction to user instrument. The Vegetation SEPP, and subsequently this Section, do not affect authorisations under other Acts that are required to be obtained in connection with the clearing of vegetation.

#### *Clearing Requiring Approval Under State or Commonwealth Legislation*

None of the exemptions listed in this section apply to any clearing of vegetation that requires an approval under any State or Commonwealth legislation, for example endangered ecological communities (EECs). It is the legal responsibility of the landowner to ensure this is considered. If unsure, further advice should be sought from the NSW Office of Environment and Heritage or Council.

### Removal of Vegetation that Does Not Require a Permit

Any tree or other vegetation may be removed without a permit where:

- Council is satisfied it presents an immediate risk to life or property,
- Council or the Native Vegetation Panel is satisfied the tree is dead or dying and is not required as the habitat of native animals,
- the clearing is authorised under Section 60O of the *Local Land Services Act 2013*,
- it is consistent with any approved development application issued by Council for the site,
- it is to be pruned as part of routine pruning of fruit trees, forestry work or commercial horticulture/viticulture,
- it is an environmental weed required to be removed under any relevant NSW legislation,
- it is an exotic environmental weed within the riparian zone of Queanbeyan River, Jerrabomberra Creek or their tributaries shown as a blue line on a topographical map,
- it is an exotic environmental weed within bushland subject to an adopted Plan of Management,
- it is located on Council Managed Lands (both Community and Operational) where the proposed works have been approved by the Service Manager – Urban Landscapes, or
- the land is zoned R5 Large Lot Residential, RE2 Private Recreation, C2 Environmental Conservation, C3 Environmental Management or C4 Environmental Living, and it falls within any of the following circumstances:
  - i. clearing for permanent boundary fence - 5 metres on either side (adjoining landholder agreement is required),
  - ii. clearing for permanent internal fence - 3 metres on either side,
  - iii. clearing around buildings other than a residential building - 10 metres from outer edge of the structure,

- iv. clearing around a water tank - 3 metres from outer edge of the structure,
- v. clearing around stockyards - 10 metres from outer edge of the structure,
- vi. clearing around a water pump - 2 metres from outer edge of the structure,
- vii. is clearing of native or exotic vegetation planted by the landowner less than 10 years old.  
Council can use aerial photography to establish where land has been cleared in the past.

Where someone is clearing vegetation under any of these exemptions, Council recommends keeping photos of the clearing, both before and after, and retaining these for a period of six months in the event Council is requested to investigate the clearing.

Vegetation clearance may be permitted in rural areas under the *Rural Fires Act 1997* under the 10/50 Vegetation Clearing Scheme (Further information is available from NSW Rural Fire Service at [www.rfs.nsw.gov.au](http://www.rfs.nsw.gov.au)). This scheme allows for clearing in a designated areas to:

- i. trees within 10m of a home; and
- ii. underlying vegetation such as shrubs (but not trees) on a property within 50m of a home.

Note: Extensive conditions surround this code and the onus is on the landowner to thoroughly investigate and document the clearing work.

### B3.5.5 Controls

#### All Zones

- 1) A permit is required for the pruning or removal of any significant trees or trees used as survey markers.

A significant tree includes all trees listed on Council Significant Tree register and including:

- Yellow Box (*Eucalyptus melliodora*) – within the road reserve, corner of Williamsdale Road and Keewong Lane

#### Land Zoned Rural (RU1 Primary Production, RU2 Rural Landscape, RU3 Forestry or RU4 Primary Production Small Lots)

The clearing of any native vegetation on land zoned RU1 Primary Production, RU2 Rural Landscape, RU3 Forestry or RU4 Primary Production Small Lots is wholly regulated by NSW Local Land Services under the *Biodiversity Conservation Act 2016*. Accordingly Council has no role in managing any clearing proposed in rural zones and any such proposals should be discussed with the relevant Local Land Services office.

#### Land Zoned Residential (R1, R2, R3, R4 and RU5), Business (B1, B2, B3, B4, B5, B6, B7 and B8, Industrial (IN1 and IN2), Special Use (SP1 and SP2) and RE1 Public Recreation

- a) No permit is required for the removal of any vegetation set out under the listed exemptions at 3.5.4 of this section.
- b) A permit is required for the removal, ringbarking, lopping, topping, poisoning, pruning or relocation of all existing trees, both native or exotic, having:
  - i. height of 6 metres or greater, or
  - ii. a canopy spread of 3 metres or greater.
- c) A permit is also required for all works affecting a “significant” tree. All trees identified as “Significant” by Council, and nominated or registered as such on Council’s significant tree register, regardless of height, canopy or location, must be retained, preserved, protected and maintained. Special requirements apply for the removal or pruning of “significant” trees. For further information on these requirements, please contact Council’s Urban Landscapes Section.

- d) Any proposed removal of a tree that is a poor specimen and is in a state of decline that is prolonged and irreversible, may need to be supported by relevant evidence from a suitably qualified person (for example a report from an Arborist).
- e) Any proposed removal of trees that have caused or are likely to cause significant structural damage may need to be supported by relevant evidence from a suitably qualified person (for example a report from a Structural Engineer).
- f) For every tree removed from a site for construction of a building it should be replaced with either a tree of similar species, or an indigenous plant species which is better suited to the changed circumstances of the site. The tree is to be replaced within the property boundary of the site it was removed from unless otherwise specified by Council.
- g) The removal or pruning of trees or other vegetation proposed to facilitate solar access for the tree owner or their neighbours is not generally supported.

The permit application must be signed by the owner(s) of the property on which the trees are growing and accompanied by the relevant fee (refer to Council's Fees and Charges).

### Land Zoned Residential R5 Large Lot Residential, RE2 Private Recreation, C2 Environmental Conservation, C3 Environmental Management and C4 Environmental Living

- a) No permit is required for the removal of any vegetation set out under the listed exemptions at 3.5.4 of this section.
- b) No permit is required for the removal of any tree less than 6 metres tall and 3m in canopy spread.
- c) A permit is required for the removal of any native vegetation. All permit applications must be accompanied by a site plan which is drawn to scale and illustrates:
  - i. the property boundary, existing structures and access roads,
  - ii. the location of all trees and other vegetation on the lot and identification of those trees or vegetation proposed for removal or pruning with approximate heights and widths,
  - iii. the total area (in m<sup>2</sup>) of clearing being applied for, and total area (in m<sup>2</sup>) of previous clearing,
  - iv. the trees or vegetation, including species name, proposed for removal or pruning,
  - v. the distance of those trees or vegetation proposed for removal or pruning from the nearest boundary and/or structure,
  - vi. if relevant, placement of drainage and sewer mains, and overhead power lines,
  - vii. the location of any known watercourses on the property; and
  - viii. a north arrow.

The permit application must be signed by the owner(s) of the property on which the trees are growing and accompanied by a report by the relevant fees (refer to Council's Fees and Charges).

Any application for a permit to clear native vegetation comprising any trees containing hollows, threatened species or that is part of an endangered ecological community, is to be accompanied by a report by a suitably qualified person. The following information is to be contained in the report:

- i. application for a permit to clear native vegetation comprising any trees containing hollows, threatened species or that is part of endangered ecological community, is to be accompanied by a report by a suitably qualified person. The following information is to be contained in the report:
- ii. the qualifications and experience of all person/s undertaking the report,
- iii. a map of the subject property including a detailed map of the proposed clearing area,

- iv. the date and time of any site inspections or surveys undertaken to inform the report, including the methodology of those surveys (the guidelines published by the NSW Office of Environment and Heritage are to be taken into account),
- v. a list of flora and fauna species identified by any survey,
- vi. a search of the NSW Wildlife Atlas and other government databases,
- vii. the impact of the development proposal on native flora and fauna,
- viii. recommendations in relation to any impacts on habitat corridors,
- ix. comments in regard to the ecological significance of the study area,
- x. location and description of any hollow bearing trees, threatened species or endangered ecological communities,
- xi. proposed mitigation measures,
- xii. species for replanting where proposed, and
- xiii. recommended biodiversity conservation strategies (if these are to be used).

For every tree removed from a site for construction of a building it should be replaced with either a tree of similar species, or an indigenous plant species which is better suited to the changed circumstances of the site.

### B3.6 Environmental Protection Works

Development that fits the definition of environmental protection works under the *QPRLEP2022* requires development consent. The dictionary of the *QPRLEP2022* provides a definition of environmental protection works.

#### Objective

- a) To ensure that environmental protection works are undertaken in a manner that benefits the natural environment.

#### Control

- 1) A report detailing the proposal is to be submitted with the development application. The report is to contain the following:
  - a) a site analysis as described in Part B1 of this DCP
  - b) the aim and timing of the works
  - c) the means of undertaking the work
  - d) environmental control methods.

#### Further information

- NSW Department of Planning and Environment [www.environment.nsw.gov.au](http://www.environment.nsw.gov.au)
- NSW Local Land Services at [www.lls.nsw.gov.au](http://www.lls.nsw.gov.au)

## B4 Bush Fire Prone Land

All new construction subject to bush fire must comply with the current version of *AS3959 Construction of Buildings in Bush Fire Prone Areas*.

Bush fire prone land is land that can support a bush fire or is likely to be subject to bush fire attack.

The Queanbeyan-Palerang Regional Council area is located within an area of Australia estimated to have one large bush fire every five years.

A Bush Fire Prone Land Map has been prepared by the Queanbeyan-Palerang Regional Council and certified by the Commissioner of the NSW Rural Fire Service. The map identifies bush fire hazards and associated buffer zones within LGA.

Category 1 vegetation – appears as orange on the Bush Fire Prone Land Map and includes forests, woodlands, heath lands, pine plantations and wetlands. Land within 100m of category 1 vegetation (indicated by the red buffer on the map) is also captured by the Bush Fire Prone Land Map due to the likelihood of bush fire attack.

Category 2 vegetation – appears as yellow on the Bush Fire Prone Land Map and includes grasslands, scrublands, rainforests, open woodlands and mallee. The land within 30m of category 2 vegetation (indicated by the red buffer on the map) is also captured by the Bush Fire Prone Land Map.

To find out if your development is in a bush fire prone area, contact council and ask to view the Palerang Bush Fire Prone Land Map or apply for a Section 10.7 Planning Certificate for the property from council.

If any part of a proposed development (including the building envelope, access roads, landscaping, or asset protection zones) falls within an area that has been mapped as bush fire prone on the relevant Bush Fire Prone Land Map, then the applicant must consider bush fire as part of the development process.

Dwelling houses in rural areas are at much greater risk of bush fire than those built in urban areas, due to the amount of fuel surrounding the houses and the potential for ember attack from bush fires in forested areas in the locality. As a result a higher Bushfire Attack Level construction level is required.

Prospective home builders should give careful consideration to the design and siting of their new home since these have been found to significantly improve the chances of buildings surviving a bush fire. The CSIRO Division of Building Research has found that to provide a good level of resistance to bush fires a building design needs to:

- prevent the establishment of small spot fires within the structure
- protect the structure from the external environment by providing adequate protective space around the structure
- allow the structure to physically withstand the impact of high wind and radiation stresses for short periods of time.

The *Environmental Planning and Assessment Act 1979* establishes a system for requiring bush fire protection measures on bush fire prone land at development application stage and the *Rural Fires Act 1997* classes certain development as integrated development and these are set out in Table 2 below.

New development on areas on any part of a lot identified as bush fire prone are subject to the development and planning controls of the NSW Rural Fire Services publication Planning for Bush Fire Protection 2019 Guidelines and must be designed to improve the survivability of the development and the occupants that are exposed to a bush fire hazard.

Table 2 Bush fire prone land and development categories

Type of Application	Complying Development	Non Integrated Development Application	Integrated Development Application
Description	Development approval which is not through the development application process	Development application site on bush fire prone land and not 'integrated'. Includes infill other than residential/rural subdivision or 'special fire protection purposes' such as seniors living, tourist facilities and schools	Residential/rural subdivision or 'special fire protection purposes' such as seniors living, tourist facilities and schools



Legislation	State Environmental Planning Policy (Exempt and Complying Development Codes) 2008	Section 79BA NSW Environmental Planning and Assessment Act 1979	Section 91 NSW Environmental Planning and Assessment Act 1979 and 100B NSW Rural Fires Act 1997
Referral	Bush fire risk must be certified/assessed by a qualified consultant or Council	Possible consultation with the NSW Rural Fire Service	A Bush Fire Safety Authority from the NSW Rural Fire Service required

The following section outlines the requirements for development on land classified as Bush Fire Prone Land within the LGA and should be read in conjunction with clause 5.11 of the *QPRLEP2022*.

## Objective

- To minimise risk to life, property and the environment from bush fire.
- To ensure compliance with the statutory obligations for development in bush fire prone areas.
- To ensure bush fire risk is managed in connection with the preservation of the ecological values of the site and adjoining lands.

## Control

### B4.1 All development applications

- Applications must satisfy the relevant provisions of *Planning for Bushfire Protection 2019*.
- Development design and the siting of building envelopes and Asset Protection Zones should consider any potential environmental impact and steps to mitigate the impact on environmentally sensitive lands. Further detailed requirements are set out in section B3.1 Terrestrial Biodiversity in this DCP.

### B4.2 Subdivision applications

- Bush fire protection measures are to be placed wholly within the development site. All proposed Asset Protection Zones are to be within the property to be subdivided and incorporated into affected lots or within the existing or proposed road reserve, or a combination of both. Asset Protection Zones will not be accepted on Council reserves, other public lands or in reserves proposed to be dedicated through the subdivision.

### B4.3 Dwelling Houses

- Development applications for dwelling houses, alterations and additions to an existing dwelling house within bush fire prone land must address the requirements contained in the NSW Rural Fire Service publication *Building in Bush Fire Prone Areas Single Dwelling Applicants Kit*

### B4.4 Integrated development

(Section 91 of the *Environmental Planning and Assessment Act 1979* and Section 100B of the *Rural Fires Act 1997*)

- Integrated development applications must be accompanied by a Bush Fire Risk Assessment report prepared by a suitably qualified and experienced bush fire consultant. The report is to outline the proposed development's consistency with the NSW Rural Fire Services *Planning for Bush Fire Protection 2006 Guidelines*, *Australian Standards AS3959-2009 Construction of Buildings in Bush Fire Prone Areas*, and any other documents that have been adopted by NSW Rural Fire Service

## References

- Australian Standards *AS3959-2009 Construction of Buildings in Bush Fire Prone Areas*
- NSW Rural Fire Services, *Planning for Bush Fire Protection 2006 Guidelines*

- NSW Rural Fire Service *Building in Bush Fire Prone Areas Single Dwelling Applicants Kit*

#### Further information

- NSW Rural Fire Service at [www.rfs.nsw.gov.au](http://www.rfs.nsw.gov.au)

## B5 Crime Prevention through Environmental Design

The design of buildings and public spaces can affect opportunities for crime and the perceptions people have in relation to security and safety. The four principles of crime prevention through environmental design that are used in the assessment of development applications to minimise the opportunities for crime are outlined below.

**Natural surveillance** – design should allow people to see what others are doing as a means to deter the potential for crime. This can be achieved by having clear sight lines between public and private places, effective lighting of public places and landscaping that makes places attractive but does not provide places to hide or entrap people.

**Access control** – physical and perceived barriers can be used to manage movements to minimise opportunities for crime. This can be achieved by creating landscapes and physical locations that channel and group pedestrians into target areas, public spaces which attract people to gather rather than discouraging them, and restricting access to internal areas of high risk that are rarely visited (e.g. car parks) often through the use of physical barriers.

**Territorial reinforcement** – increasing the community ownership of public spaces increases activity levels and encourages people to help prevent crime. This can be achieved by designing places that encourages people to gather and to feel some responsibility for its use and condition, having clear transitions between private and public space and using design cues on who is to use the space.

**Space management** – public spaces that are attractive and well maintained are more likely to be inviting and well used. This can be achieved through the implementation of strategies that includes site cleanliness, repair and removal of vandalism and graffiti, replacement of lighting when required and general upkeep of the street furniture and fixtures.

All development applications will be assessed against the crime prevention through environmental design general principles.

A Crime Risk Assessment may be required for high risk developments.

### Objective

- To ensure the incorporation of crime prevention strategies in new development
- To promote active, pedestrian and cyclist orientated environments where developments are designed to integrate into the public domain
- To maximise opportunities for natural surveillance of public spaces, buildings, site entrances and internal spaces

### Control

- The four crime prevention principles through environmental design general design principles are to be considered in the design of all developments
- Public, semi-public and private areas are to be clearly defined
- Natural surveillance is to be provided to communal and public places in the design of the development
- Landscaping that obstructs casual surveillance and allows intruders to hide should not be used. Note: Plants such as low hedges and shrubs, creepers, ground covers and high canopied vegetation are good for natural surveillance
- Large shrubs, trees and building works that could enable an intruder to gain access to a dwelling or neighbouring dwelling should be avoided

- 6) Lighting to enable natural surveillance, particularly in entrances and exits, service areas, pathways and car parks is to be provided in accordance with the relevant Australian Standard. The lighting is to be designed and sited to minimise spill and potential nuisance to adjoining properties
- 7) An appropriate level of security for individual dwellings and communal areas should be provided to reduce opportunity for unauthorised access
- 8) Dwellings and communal areas are to be designed to provide a sense of ownership
- 9) Public facilities (for example Automatic Teller Machines, telephones, bicycle storage) are to be located in areas of high activity
- 10) Fence design is to maximise the natural surveillance from the street to the building and from the building to the street and minimise the opportunities to hide
- 11) Entries are to be clearly visible and identifiable from the street
- 12) Entrances are to be designed to allow users to see into the building before entering
- 13) Administration areas and offices in industrial developments are to be located at the front of the building
- 14) Blank walls along street frontages are to be minimised
- 15) Blind corners in pathways, stairwells, hallways and car parks are to be avoided
- 16) Public toilets and rest areas are to be located to promote their use and maximise public surveillance without creating visual intrusion
- 17) Dwellings are to be clearly identified by a street number to prevent unintended access and to assist persons trying to find the dwelling

#### Further information

- NSW Police-Safer by Design at [www.police.nsw.gov.au/community\\_issues/crime\\_prevention/safer\\_by\\_design](http://www.police.nsw.gov.au/community_issues/crime_prevention/safer_by_design)

## B6 Development on ridges and prominent hills and within 200 metres of a classified road

Ridges and hillsides are important visual reference points and contribute to the character of the landscape. Development on hilltops, escarpments and ridges and within 200 metres of a classified road can have a negative visual impact in rural and environmental land use zones and alter the character of an area. It is generally possible to maintain the visual amenity of a rural area whilst enabling development if measures such as changing the location of the proposed development, establishing and maintaining a vegetation screen or by using materials that 'blend' the development with the natural environment.

#### Objective

- a) To ensure that development does not detract from the visual amenity and does not reduce the rural character of an area

#### Control

- 1) Buildings, infrastructure or services are to be kept below significant ridgelines or hilltops
- 2) Outbuildings and water tanks associated with dwellings are not to be visually prominent
- 3) Lots being created for residential subdivision are to be sited so that buildings, infrastructure or services are below ridgelines
- 4) Building envelopes are to be sited to avoid buildings being prominent in a rural landscape
- 5) Development within 200 metres of a classified road in the rural and environmental land use zones is to be avoided
- 6) Low-reflectivity roofing materials are to be used
- 7) Materials and colours are to be sympathetic to the natural environment
- 8) Vegetation is not to be removed from ridgelines

- 9) A vegetation screen is to be established and maintained at the commencement of construction. The vegetation screen is to consist of plants indigenous to the area
- 10) Depending on the scale, location and nature of the development a visual impact analysis may be required

## B7 Engineering Requirements

### B7.1 Parking

#### Objective

- a) To ensure development provides parking spaces commensurate with the intended use of the site
- b) To ensure the design and location of parking areas and other areas used for the movement of vehicles and pedestrians is efficient, safe and convenient, and integrated into the design of the development to minimise the visual impact
- c) To ensure that adequate car parking spaces are available within convenient walking distance of the commercial centre of Bungendore and other traffic generating developments.
- d) To ensure that car parking sites are designed for access and mobility
- e) To ensure that car parking sites consider parking for bicycles, mobility scooters, electric vehicles and motorcycles
- f) To ensure car parking is designed to reduce unwanted environmental impacts, such as redirecting stormwater onto adjacent properties
- g) To ensure appropriate loading and service vehicle areas are provided in parking areas

#### Control

- 1) Off-street parking is to be provided on the development site or in a centralised Council operated parking area where the land is zoned B2 or B4
- 2) Development that leads to a loss of on-street or off-street parking is to provide the same number of lost parking spaces in parking areas associated with the development, in addition to that required by the development itself
- 3) Provision is to be made for service vehicles on-site. Parking and loading areas are to be commensurate with the nature of the development and to the requirements of AS2890
- 4) All vehicles are to enter and leave the site (except residential developments) in a forward direction
- 5) Off-street car parking areas are to be surfaced with an appropriate wearing course. Pavement designs are to conform to AUSSPEC #1 Specification Series (as amended by Council)
- 6) Parking for people with a disability shall be supplied in the numbers provided in Table D3.5 of the Disability (Access to Premises – Buildings) Standards 2010 and to the requirements of AS1428 and AS2890
- 7) Car park design is to enable safe pedestrian movements and reduce pedestrian/vehicle interactions. Car park design is to exclude pedestrian movement through areas that will be used by service vehicles for reversing
- 8) Landscaping is to be provided to soften hard surfaces and provide shade
- 9) Car parking areas are to have suitable drainage and incorporate water sensitive urban design elements where appropriate
- 10) Underground carparking areas are to have the level of their entrance (and all other openings such as pedestrian doors and air vents) at or above the flood planning level, see B9 Flood Planning
- 11) Lighting is to be provided to the appropriate levels as defined in AS1158
- 12) Off-street car parking is to comply with the following documents:
  - *Disability (Access to Premises – Buildings) Standards*

- *AS 2890 - Parking Facilities*
- *AS 1428 - Design for Access and Mobility*
- *AS 1158 - Road Lighting*
- *AS 1742.11 - Manual of uniform traffic control devices, Part 11: Parking Controls*
- *NSW Roads and Traffic Authority Guide to Traffic Generating Developments*
- *Austrroads Guide to Traffic Management Part 11: Parking*
- *Austrroads Guidelines for Planning and Assessment of Road Freight Access in Industrial*

## Development application requirements

The following matters are to be taken into consideration when considering off-street car parking in relation to development:

- existing on-site parking provisions
- the availability of public parking facilities in the area
- the likely demand for off-street parking generated by the development and in the case of a redevelopment, the likely increased demand that will arise and the likely peak parking demand
- the impact of increased traffic on the existing road capacity

Development applications, where off-street parking is part of the proposed development, are to include the following information:

- parking and manoeuvring areas including pedestrian movement and special parking zones (such as bicycle, seniors or parent parking)
- parking area entry/exit locations and dimensions
- accessible parking locations
- loading/unloading, service delivery frequency and type, vehicle swept paths
- sign posting and line marking
- waste collection areas
- landscaping
- pavement construction
- drainage systems
- lighting

In addition, a report will be required detailing how the proposed parking area complies with the documents referred to in this section of the DCP.

## B7.2 Roads

### Objective

- To ensure new or upgraded roads provide for safe and efficient movement for all road users including pedestrians, cyclists and other non-vehicular road users
- To ensure new or upgraded roads integrate with the Palerang local government area road network and hierarchy
- To ensure new or upgraded roads have an appropriate road design for the intended development.
- To ensure new and upgraded roads are designed to reduce unwanted environmental impacts
- To ensure new and upgraded roads are designed to manage risk to road users
- To ensure all lots have suitable, safe and efficient access to and from public roads and that all road and stormwater drainage infrastructure works are properly constructed.

## Control

- 1) Design and construction is to be in accordance with Austroads Guide to Road Design (and NSW Roads and Maritime Services supplements), AUSSPEC #1 Specification Series (as amended by Council)
- 2) Roads are to comply with the road hierarchy shown in Table 3 for urban areas and Table 4 for rural areas of this DCP
- 3) Verges are to comply with the road hierarchy shown in Table 3 for urban areas and Table 4 for rural areas and provide a suitable surface for a continuous path of travel
- 4) Street lighting is to be designed and installed in accordance with AS1158 in areas zoned B2, B4, IN2, R1, R2, RE1 and RU5. New roads in other land zones may require lighting at major intersections
- 5) All roads in urban areas are to have kerb and guttering as required in the road hierarchy shown in Table 3 of this DCP
- 6) All new and upgraded public roads in B2, B4, RU5, IN2, R1, R2, R5 and SP2 are to be sealed and are to be accessed via sealed roads. Sealing of public roads in other zones may be required. All roads are to have appropriate pavement drainage controls.
- 7) Bus facilities, including bus shelters, parking areas and turning areas if appropriate (such as in rural locations), are to be provided at appropriate locations and to the standards of relevant regulatory and legislative requirements
- 8) The design of roads is to consider the location and impact of proposed works on native vegetation, significant trees, European and Aboriginal heritage and significant rock outcrops, see B3 Flora and Fauna, Soil and Watercourses
- 9) All lots in a subdivision, or vacant lots where new residential development is proposed, must have coinciding physical and legal access to / from a properly formed public road
- 10) In areas where an applicant proposal fronts a poorly constructed or unformed public road, the subdivision will be required to construct full kerb and gutter, stormwater drainage, full or half road construction and sealing in addition to the provision of nature strips with a 3% cross fall to the roadway. Generally, kerb and gutter and verge areas will not be required in RU1, C2, C3, RU5 and C4 zones
- 11) The sealing of sections of gravel road where extra traffic generated will cause the need to address dust impacts adjacent to existing or proposed dwellings (in accordance with Table 4) will be required

## Development application requirements

All development applications involving the construction of new roads, or substantial upgrades of existing roads, shall be submitted with drawings. Drawings are to be prepared by suitably qualified persons as set out in *AUSSPEC #1 Specification Series (as amended by Council)* and shall comply with the requirements of this document. Drawings shall be presented at appropriate scales (as set out in *AUSSPEC #1*) and shall contain the following information:

- locality plan showing entire development on one sheet;
- general layout plans including
  - proposed road centre lines (including all off-road cycleways/footpaths) labelled with a unique identifier, e.g. "Road 1"
  - road widths and curve radii
  - drainage, culvert or bridge locations
  - entrances and the justification for their location including sight distance diagrams for road intersections; and
  - water, stormwater and sewer main locations
- road centreline longitudinal sections (including all off-road cycleways/footpaths)
- typical road cross sections including details on the road surface

- contours, watercourses and drainage lines and a catchment analysis
- existing and proposed easements, railways and Crown Public Roads and any proposals to close them; and
- underground and above ground infrastructure such as gas, telecommunications, wastewater, water and electricity infrastructure
- trees and areas of significant native vegetation

In addition, a report shall be required detailing the assumptions and design criteria used in the design of the roads and how impacts on native vegetation, significant trees, European and Aboriginal heritage and significant rock outcrops have been minimised. The report shall also address steps taken in the design process to minimise risks to all road users categories when completed (*Note*: this does not need to include an assessment of risk during construction).

Prior to submitting the development application, proposed road centrelines and lot boundaries shall be pegged at 25m intervals. Pegs shall also be placed at curve tangent points and midpoints prior to submitting the development application. The top of pegs shall be a minimum 1.0m above the existing ground surface and shall have either highly visible tape attached to the peg or be painted (100mm wide from the top of the peg) in an appropriate colour.

PTO

Table 3 Urban zone street standards

STREET/ROAD TYPE	UP (A)	UL	U1	U2	U3	U4
Category/Purpose	Private Road	Lane	Access Street	Local Street	Collector Street	Local Sub Arterial
Number of Lots Served	1	1-14	1-14	15-285	286-428	>429
VPD (AADT)/Lot	7	7	7	7	7	7
Traffic Volumes (VPD AADT)	-	7-98	7-98	99-1995	1996-2996	>2997
Carriageway Width (m)	3.0 (B)	5.0	6.0	8.0	9.0	11.0
Minimum Verge Width	-	1.0	4.5	4.5	4.5	5.5
Footpath Requirement (C)	-	-	1.5 (one side only)	1.5 (one side only)	1.5 (one side only)	1.5 (one side only)
Nominal Road Reserve Width (m) (F)	-	8.5	15	17	20	22
Street Trees	NIL	NIL	1 street tree per 2 lot frontages on alternate sides of the street			
Kerb type (G)	FLUSH/ROLL	FLUSH/ROLL	FLUSH/ROLL	ROLL/BARRIER	BARRIER	BARRIER
Design speed (km/h) (D)	10	25	25	40	50	60
Maximum Grade %	20	20	20	20	15	10
Drainage Design Frequency						
Minor	10	10	10	10	10	10
Major	100	100	100	100	100	100
Design Traffic Loadings (ESAs) (E)		2 x 103	2 x 103	4 x 103	1 x 104	3.4 x 104



- VPD** Vehicles per day  
**AADT** Average Annual Daily Traffic  
**ESAs** Equivalent Standard Axles

**NOTES:**

- a) Design speed, horizontal and vertical geometry not specified for Type UP road. Type UP roads shall comply with the requirements of *AS2890* and emergency services
- b) Width to suit requirements of *AS2890* and emergency services
- c) Wider footpaths will be required if shown in the Pedestrian and Mobility Plan. Verge widths may need to be increased to suit
- d) Lower or higher design speed may be specified in special circumstances of topographical or environmental conservation constraints/circumstances. Road alignments shall be designed so as to ensure a consistent or gradually changing speed environment so that each curve is not incongruous with the adjoining curves thereby 'trapping' unwary drivers. In this regard where terrain or environment dictate a reduction in speed environment, geometric elements connecting the two speed environments should be designed with appropriate design speeds to provide a speed transition between elements of not more than 15-20 km/h. All curves and crests which have a design speed less than the posted speed limit shall be provided with appropriate speed warning signs on each approach
- e) Pavement design, materials and construction to be in accordance with AUSSPEC #1, which refers to specific publications
- f) Nominal road reserve widths do not cater for all situations. Additional road reserve is required where necessary to accommodate features such as drainage swales, bus bays and intersections splays.
- g) If an area in an RU5 zone does not have kerb and guttering it will not be required.

Table 3 Urban zone street standards

ROAD TYPE	RP1	RP2	RP3 (A)	RS1	RS2	RS3	RS4
Category/Purpose	Single Lot Private Access (A)	Residential Private Access (A)	Minor Rural Road	Local Road	Access Road	Collector Road	Arterial Road
Number of Lots Served	1	2-5	1-5	2-21	22-71	72-142	>142
VPD (AADT)/Lot	7	7	7	7	7	7	7
Traffic Volumes (VPD AADT)	7	8-35	35	7-147	148-497	498-994	>994
Minimum Pavement Formation Width (m)	4.0 (B)	6.0	9.2	9.2	9.2	10.0	11.0
Minimum Verge Widths (C)		-					
a. Embankments	-	1.0	1.0	1.0	1.0	1.5	2.0
b. Cuttings	-	1.0	1.5	1.25	1.5	2.0	2.0
Seal Width Requirements (D)							
a. Lanes (m)	-	-	N/A	2 @ 3.1	2 @ 3.1	2 @ 3.5	2 @ 3.5
b. Shoulders (m)	-	-	N/A	2 @ 0.5	2 @ 0.5	2 @ 1.0	2 @ 1.0
c. Total (m)	-	-	N/A	7.2	7.2	8.5	9.5
Verge Track Width (m) (E)	-	-	1.5 (one side only)	1.5 (one side only)	1.5 (one side only)	1.5 (one side only)	1.5 (one side only)

Nominal Road Reserve Width (m) (F) (G)	-	-		20	25	30	30
ROAD TYPE	RP1	RP2		RS1	RS2	RS3	RS4
Design Speed (km/h) (H)	-	-		60	70	80	80-100
Maximum Grade % (I)							
a. Unsealed surface using erosion resistant gravels	15	15		-	-	-	-
c. Unsealed surface using sandy decomposed granite	7	7		-	-	-	-
b. Sealed surface	20	20		14	12	12	12
Drainage Design Frequency (i)	-	2		20	50	100	100
(ii)	-	2		10	25	50	50
1 in....Years (J) (iii)	-	2		5	10	20	20
(iv)	-	2		2	5	10	10
Minimum Basecourse Thickness (mm) (K)	100	100		150	150	200	200
Design Traffic Loadings (ESAs)	$2 \times 10^3$	$1 \times 10^4$		$4.2 \times 10^4$	$2.2 \times 10^5$	$6.6 \times 10^5$	$1.1 \times 10^6$

**VPD** Vehicles per day

**AADT** Average Annual Daily Traffic

**ESAs** Equivalent Standard Axles

**NOTES:**

- a) Type RP1 and RP2 roads are for private roads only, and design speed, horizontal and vertical geometry are therefore not specified for these roads. These roads are to be aligned to minimise impact on, or interference/disturbance of native vegetation, significant trees, water courses, rock outcrops, and items of Aboriginal and European heritage. Vertical geometry is to follow the natural surface and avoid cuts/fills deeper/higher than 0.5 metre as far as practicable. Longitudinal table drains where needed are to be as small as practicable and are to be turned out to level spreaders at 20 metre (max) intervals or terminated at cross drainage culverts/causeways at 50 metre (max) intervals. Type RP3 roads shall only be constructed in the E3 and RU1 land use zones where existing roads are unsealed and greater than one kilometre in length.
- b) If required by Rural Fire Service documentation passing bays shall be constructed in a bush fire prone area.
- c) Verge widths adjacent to carriageway shall be as specified in the table and as shown in the Typical Cross Section below. Where not specified in the table, keep widths to practicable minimums.
- d) Delineation is required in accordance with Austroads and Roads and Maritime Service standards. On public roads where it has been determined sealing is not required, lane and shoulder widths shall be as per the sealing width requirements.
- e) Verge tracks are to be provided at a safe location away from vehicle traffic (i.e. not against the shoulder) and have a maximum crossfall of 4%. Refer to Typical Cross Section below.
- f) A reduction in the road reserve width may be permitted in flatter terrain if it can be demonstrated that the road formation, cut and fill batters, drainage, lateral clearances at top and bottom of batters of at least 2.5m and horse trails and services can be adequately incorporated within the road boundaries.
- g) Stock proof fencing shall be provided along public road reserves. Refer to C30.
- h) Lower or higher design speeds may be specified in special circumstances of topographical or environmental conservation constraints. Road alignments shall be designed so as to ensure a consistent or gradually changing speed environment so that each curve is not incongruous with the adjoining curves thereby 'trapping' unwary drivers. In this regard where the terrain or environment dictates a reduction in speed environment, geometric elements connecting the two speed environments should be designed with appropriate design speeds to provide a speed transition between elements of not more than 15-20 km/h. All curves and crests which have a design speed less than the posted speed limit shall be provided with appropriate speed warning signs on each approach.
- i) Permanent erosion protection, sediment control and revegetation is to be designed and constructed to protect disturbed surfaces along and adjacent to roadsides, table drains and drainage structures in accordance with sound drainage design and environmental principles. For gravel roads, a small increase in maximum grade may be accepted if the road is over a steeper section is finished with a non-erodible or bitumen sealed pavement. V-shaped table drains are not acceptable.
- j) Adequate provision shall be made for overtopping in accordance with AUSTROADS 'Bridge Design Code'.
  - i. Bridge Structure with effective waterway area > 30 m<sup>2</sup>
  - ii. Major Culvert Structure with effective waterway area > 3 < 30 m<sup>2</sup>
  - iii. Minor Culvert Structure with effective waterway area < 3 m<sup>2</sup>
  - iv. Catch Drains
 Additional erosion control works or overtopping structures may be required.
- k) Pavement design, materials and construction to be in accordance with AUSSPEC #1, which refers to specific publications.

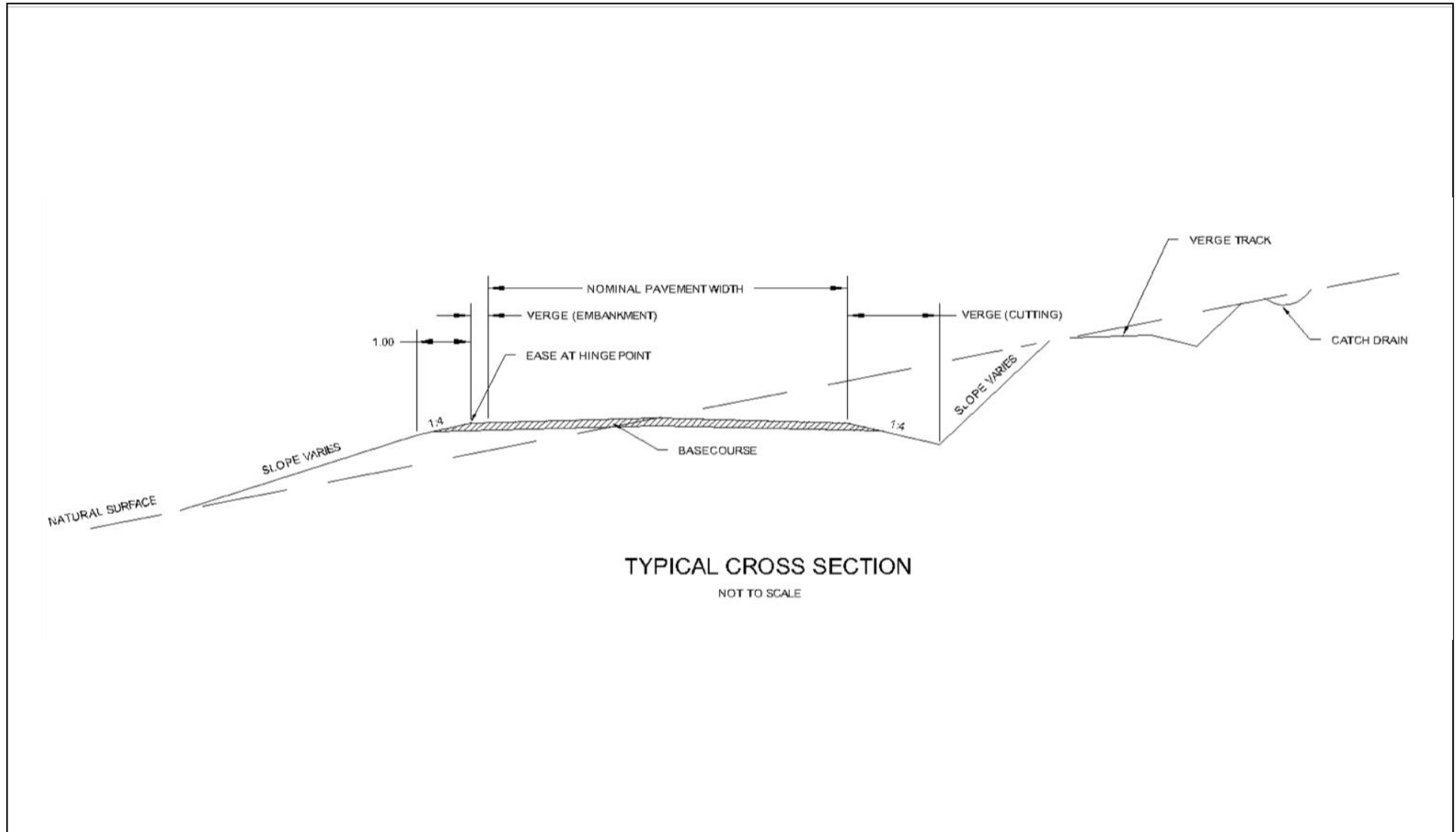

## B7.3 Urban Vehicle Access

### Objective

- a) To ensure vehicles are able to enter and exit properties in a safe manner
- b) To ensure vehicle accesses do not unnecessarily restrict on-street parking

### Control

- 1) Vehicular access and car parking areas are to comply with *AS 2890 - Parking Facilities*. Suitable transitions are to be provided to the public road
- 2) Driveways are to be offset a minimum of 0.9m from side boundaries to allow effective screen planting along the boundary
- 3) The driveway within the property is to be minimum 3.0m wide, with adequate turning area provided to allow ease of access to garages
- 4) The width of the driveway crossing within the road reserve shall be 3.0m
- 5) Landscaping, mailboxes, fences and other structures, where located near driveway crossings, are not to compromise safety aspects such as sight distance for both pedestrians and vehicles
- 6) The driveway crossing location and dimensions are to comply with Palerang Council standard drawings PAL-SD-102 to PAL-SD-111. Refer to Appendix A for details
- 7) Vehicular access is to be located clear of services as shown in Palerang Council standard drawings PAL-SD-108. Refer to Appendix A for details

### Development application requirements

Drawings are to contain the following information:

- Site plan showing intended access, dimensions and offset to the nearest side boundary and the location of any utilities such as stormwater pits, water mains, telecommunication pits or street trees
- Description of pavement material, for example concrete, pavers, compacted gravel
- A longitudinal section for the driveway where the difference between the back of kerb and garage/carport entry exceeds 600mm in height

## B7.4 Laneways

### B7.4.1 Existing Laneways

The urban areas of Bungendore and Captains Flat have a number of existing laneways, as shown in Figure 1 to Figure 2.

PTO

Figure 1 Existing Laneways – Bungendore

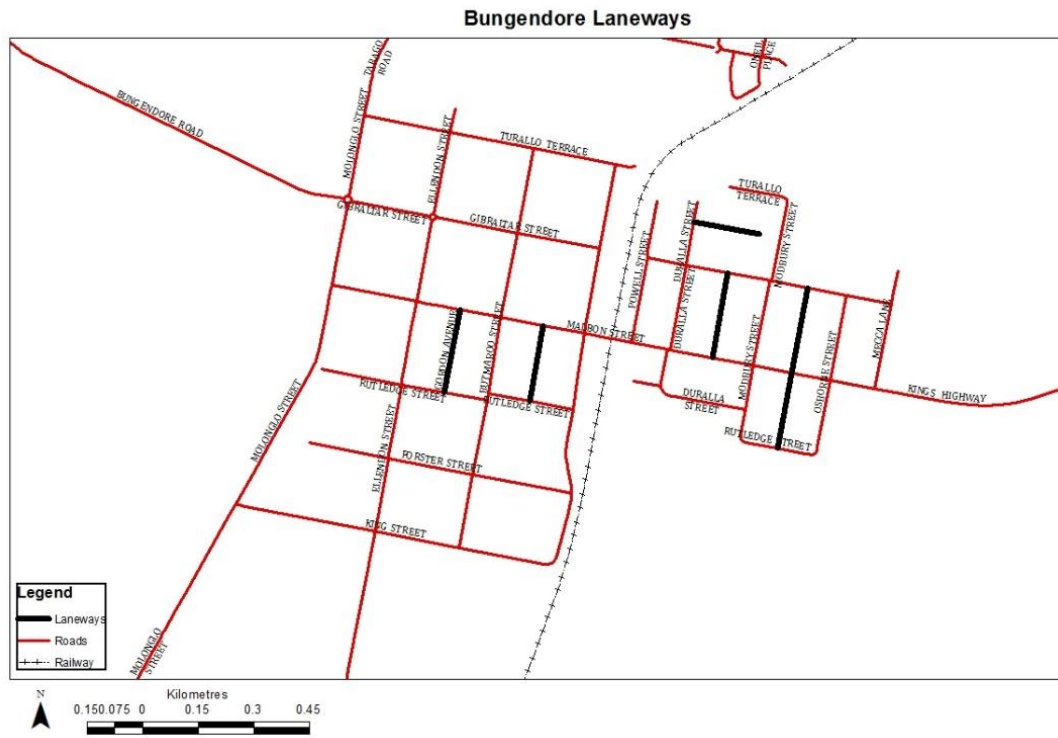
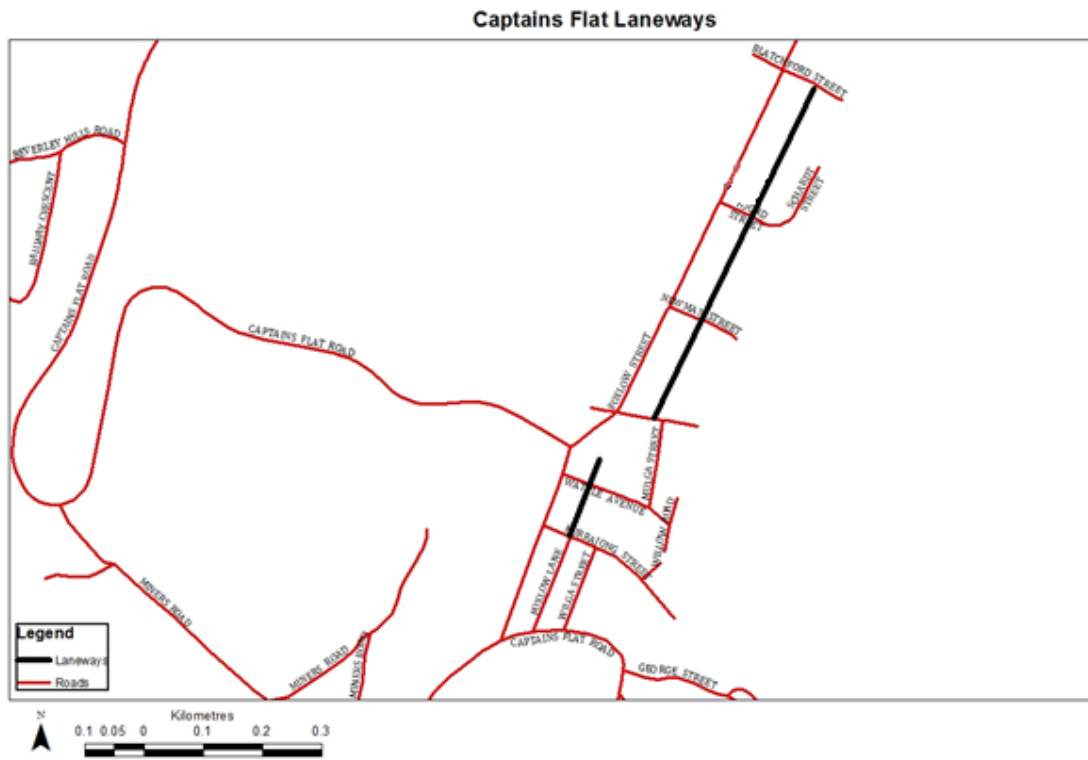

Figure 2 Existing Laneways – Captains Flat



Access via lanes facilitates the development of infill dwellings at the rear of existing residences. These dwellings would utilise the lane as their sole access to the street network. This facilitates the greater use of urban land (thereby avoiding urban sprawl) without detrimentally affecting the streetscape and character of an area.

The use of lanes provides a superior living environment to battle axe development. It is preferable for dwellings to face streets and lanes, thus having an 'outlook' and direct, private access, rather than be enclosed in backyards. It also contributes to personal safety through surveillance.

### Objective

- a) To facilitate infill residential development in Bungendore and Captains Flat
- b) To retain or enhance the streetscape and character of an area

### Control

- 1) The laneway must be the only access point to the lot
- 2) Lanes are to be 8 metres in width to provide for pedestrian and vehicular movement, parking, utilities and some landscaping
- 3) Land must be dedicated to Council to ensure that the laneway will be a Council owned and maintained road
- 4) The laneway is to be sealed

### B7.4.2 New Laneways

Laneways are not appropriate for greenfield developments for the reasons outlined below:

- Narrow carriageways reduce the efficiency of commuter and commercial vehicles
- Narrow road reserves reduce the ease of utility service provision and stormwater drainage
- Narrow road reserves reduce the safety for pedestrians and other vulnerable road users

### Objectives

- a) to provide a suitable standard of road for existing lanes in urban zones
- b) to provide a superior living environment to battleaxe development
- c) to provide sufficient road reserve to supply utilities and stormwater drainage
- d) to ensure subdivisions appropriately address existing laneways
- e) to increase safety and security for pedestrians, other road users and adjoining properties
- f) to prevent the construction of new laneways in urban areas unless located within private land

### Controls

- 1) The laneway must be the only access point to the new lot
- 2) For developments involving laneways in an infill subdivision, the laneways are to be 8 metres in width and all land under the laneway is to be dedicated to Council
- 3) Developments involving subdivisions are required to seal the laneway
- 4) Pedestrian and vehicle access to rear lot is via the laneway only
- 5) Laneways are designed and signposted for one-way traffic movement
- 6) Laneways are not to be included in greenfield development requiring new roads

### B7.5 Rural Internal Access Roads

#### Objective

- a) To ensure vehicles can access dwellings or building envelopes in a safe manner
- b) To ensure access roads meet the requirements of Planning for Bush fire Protection
- c) To ensure access roads have a minimal environmental impact



## Control

- 1) Access roads are to comply with road types as defined in Table 4 in section B7.2
- 2) Access roads are to be traversable by two-wheel drive vehicles in all-weather conditions
- 3) Access roads are to meet the requirements of *Planning for Bush fire Protection 2019*.
- 4) Permanent erosion and sediment control measures are to be in place to limit water velocities
- 5) Access roads are not to traverse areas of environmental significance such as waterlogged areas or heavily vegetated areas and avoid traversing steep slopes where possible
- 6) Unsealed roads are to have a maximum grade of 15 per cent when erosion resistant gravels are used and 7 per cent where more erodible gravels such as sandy decomposed granites are used. In some circumstances where roads are sealed the grade can be increased to 20 percent
- 7) Drawings or reports are to be prepared by a person experienced and qualified in design and construction of rural access roads as set out in *AUS-SPEC #1 Development Specification Series Design* as amended by Palerang Council

## Development application requirements

Drawings are to contain the following information:

- Site plan showing intended access road centreline. The plan also should show significant features such as drainage lines, vegetation and rock outcrops in the vicinity of the access road
- A typical section for the access road
- A longitudinal section for the access road
- The location of any cross-drainage structures such as culverts
- Erosion and sediment control plan in accordance with section B8

## B7.6 Rural Entrances

### Objective

- a) To ensure vehicles can enter and exit properties in a safe manner
- b) To ensure vehicle entrances are sited in safe locations

### Control

- 1) Vehicular access complies with the provisions of *AS 2890 - Parking Facilities*. Suitable transitions are provided to the public road.
- 2) Vehicular entrances are located with safe intersection sight distance in both directions. Where not practical, vehicular entrances are located with safe stopping distance available in both directions (the impracticality of the entrance must be justified to Council's satisfaction).
- 3) Gates are to be located with sufficient setback to allow the design vehicle to wait without presenting a hazard to through traffic. Unless stated otherwise, the design vehicle shall be a 12.5m heavy rigid vehicle.
- 4) Culverts, where applicable, are set back outside the road clear zone.
- 5) Entrances are generally designed and constructed to the requirements of Palerang Council standard drawings PAL-SD-101. Refer to appendix A for details
- 6) Landscaping, mailboxes, fences and other structures, where located near driveway crossings, are not to compromise safety aspects such as sight distances for all road users

## Development application requirements

Drawings are to contain the following information:

- Site plan showing intended access location
- Sight distance diagrams showing compliance with *Austrroads Guide to Road Design* (and Roads and Maritime Services supplements) for the appropriate road speed zone

## B7.7 Stormwater and water sensitive urban design

### Objective

- a) To minimise the potential impacts of development and other associated activities on the aesthetic, recreational and ecological values of receiving waters
- b) To ensure stormwater is controlled in a way that minimises nuisance to neighbouring properties
- c) To set minimum standards for the collection and management of stormwater on development sites.
- d) To preserve natural drainage systems, where practicable, and to provide for the repair and enhancement of environmentally significant or degraded land
- e) To ensure appropriate easements are provided over existing drainage systems on private property

### Control

- 1) Stormwater and drainage systems are to comply with Parts B1 of this DCP
- 2) Easements are to be provided for all new and existing stormwater infrastructure
- 3) Single dwellings are to comply with BASIX water consumption reduction targets
- 4) Stormwater from all development (excluding single dwellings) leaving the site is to meet the performance targets set out in Table 5

**Table 5 Water Quality and Quantity Performance Targets**

Criterion	Target Reduction	Comment
Annual Suspended Solids Export Load	80%	When compared to post-construction site if no controls were implemented
Annual Total Phosphorous Export Load	65%	
Annual Total Nitrogen Export Load	45%	
Reduction of runoff peak flow to no more than the pre-development levels	3 month ARI	Captured flow to be released over a period of 1 to 3 days
Reduction of peak flows to pre-development levels	5 year to 100 year ARI	

### Development application requirements

Preliminary engineering plans and supporting documents are required for development applications. Plans are to be prepared by a suitably qualified person and to comply with Aus-Spec as amended by Council. Drawings are to contain the following information;

- Site plan showing intended minor drainage
- Site plan showing intended major drainage
- Water sensitive urban design plan and modelling
- Catchment plan
- Life cycle costing for all water sensitive urban design aspects

## B7.8 Footpaths and Verges

### Objective

- a) To ensure all road verges have sufficient width to accommodate all utilities, street lighting, footpaths, bus facilities and street trees
- b) To ensure all road verges provide a safe environment for vehicular and non-vehicular road users
- c) To ensure services are located in shared service trenches where appropriate
- d) To ensure road verges are compliant (where practicable) with Australian Standards related to accessibility

### Control

- 1) Structures and services are not to restrict sight distances for road users
- 2) Protective measures, such as guard rail, are to be employed in accordance with Austroads standards (and RMS supplements)
- 3) Verge widths are to be of sufficient width to accommodate all services and street trees where appropriate
- 4) Shared services trenches are to comply with offsets and requirements as specified by individual utility providers.
- 5) Utility allocations are to comply with section B7.8
- 6) Verge crossfalls must not exceed 3% from boundary to the back of kerb
- 7) Footpath crossfalls comply with the requirements of *AS1428* and *Disability Access Standards*

### Development application requirements

Refer to section B7.2 and B7.3 for development application requirements

## B7.9 Utilities

### Objective

- a) To ensure all developments have adequate services to cater for future development, including water for domestic and fire fighting purposes
- b) To enable installation, maintenance and augmentation of services in a cost effective manner and with minimal impact on the environment

### Control

- 1) Utilities are to be provided at subdivision stage to each lot in accordance with the Table 6 over:

PTO

Table 6 Utility requirements

Zoning \ Services	B2/B4/IN2	E3/E4	R1/R2	RU1	RU5/R5
Water	R	S1	R	S1	S2
Gas	D	N	D	N	N
Sewer	R	S3	R	S3	S4
Electricity	R	S5	R	S5	R
Telecommunications	R	R	R	R	R
R - REQUIRED	Utility must be provided				
N - NOT REQUIRED					
D - DESIRABLE	Evidence must be provided from service provider indicating that they do not wish to provide the utility				
S1 - SPECIAL	Refer to B7.9 of this DCP for controls for provision of water in areas not serviced by reticulated water				
S2 - SPECIAL	Required if the site is serviced by reticulated water. Refer to B7.9 of this DCP for controls for provision of water in areas not serviced by reticulated water				
S3 - SPECIAL	Refer to the B13 of this DCP for controls for on-site sewage management in areas not serviced by reticulated sewer				
S4 - SPECIAL	Required if the site is serviced by reticulated sewer. Refer to B7.9 of this DCP for controls for on-site sewage management in areas not serviced by reticulated sewer				
S5 - SPECIAL	Required except where adequate provision can be made for alternative power sources				

- 2) The provision of reticulated natural gas is highly desirable in areas where gas is located nearby, such as Bungendore
- 3) All services are to be underground. Where overhead electricity wiring exists in established areas, Council may vary this standard to provide for reasonable connection to the existing system
- 4) Services are to be located within shared service trenches where appropriate
- 5) Public services within private property are to be located within easements as shown in Table 7:

Table 7 Easement requirements

Service	Service Diameter (mm)	Minimum Easement Width (m)
Water	≤150	2.5
	200-375	3.0
	>375	Discuss with Council
Sewer	≤225	2.5
	300 - 375	3.5
	>375	Discuss with Council
Stormwater	<375	1.5
	375 - 675	2.5
	750 - 1200	3.5
	>1200	Discuss with Council
Combined Services	Any	Sized to accommodate services with appropriate clearances. Minimum width 3.5m.
Gas/Communications/Electricity	-	To the requirements of service providers

- 6) Utility services are not to adversely affect the viability of significant vegetation and waterways
- 7) Street lighting is to comply with the current version of AS 1158 and is to be designed to minimise on-going electricity costs to Council
- 8) Designs are to comply with the Model Agreement for Local Councils and Utility/Service Providers and the Guide to Codes & Practices for Streets Opening

### Development application requirements

All development applications involving the construction of utility services shall be submitted with suitable drawings to assess the proposal. Drawings are to be prepared by suitably qualified persons as set out in *AUSSPEC #1 Specification Series* (as amended by Council) and shall comply with the requirements of this document. Drawings shall be presented at appropriate scales (as set out in *AUSSPEC #1*) and shall contain the following information:

- general layout plans including:
  - Proposed and existing electricity, gas, telecommunications and all other non-Council owned service alignments
  - Alignments of existing and proposed Council water, sewer and stormwater infrastructure

### B7.10 Sewer and Water

**Note:** Where sewer and water are not available refer to sections B13 On-site System of Sewage Management and B17 Rainwater tanks

#### Objective

- a) To ensure water and sewerage infrastructure meets the needs of the development
- b) To ensure that water and sewerage infrastructure provided by the development does not place an unreasonable burden on the community
- c) To ensure that the infrastructure required to service a development is funded by the development and is provided in a logical and timely manner

#### Control

- 1) Development applications are to include an Infrastructure Servicing Plan prepared by a qualified engineer that identifies servicing requirements necessary for the development and any upgrades proposed to the existing system. The Infrastructure Servicing Plan shall include underground and aboveground utilities
- 2) Development applications for subdivision or major development are to consider the timing and staging of infrastructure provision including:
  - Demonstrating that water and sewerage reticulation is able to be provided having regard to the existing water mains and proposed sewer servicing strategy
  - Forward funding of any infrastructure headworks ahead of Council's program of works
- 3) All lots are to be provided with water and sewer connections suitable for the intended development where existing infrastructure is located within reasonable proximity
- 4) Water and sewer are to be designed in accordance with the *Water Supply Code of Australia (Version 3.1)*, *Sewerage Code of Australia (Version 2.3)* and *Sewage Pumping Station Code of Australia (Version 2.1)* as published by Water Services Association of Australia, *AUSSPEC #1 Specification Series* (as amended by Council) and industry best practice

## B8 Erosion and Sediment Control

Sedimentation from development sites is a major pollutant for water courses and drainage systems, causing significant environmental damage as it results in phosphorus, micro-organisms, and chemicals polluting waterways. Therefore there is a need to ensure that when a site is developed appropriate

measures are implemented to prevent the loss of sediment and to rehabilitate the site through interim and long term measures. To this end one of two kinds of plans is to be submitted with all development applications which require disturbance to soil:

- an Erosion and Sediment Control Plan or
- a Soil and Water Management Plan

Table 8 sets out the broad categories of development and the type of plan required. The requirements should be confirmed with Council at a pre lodgement meeting.

**Table 8 Erosion and sediment control plan by activity type**

Area of disturbance	Nominal type of activity	Type of plan
<250m <sup>2</sup>	house extensions, small driveways and garages	consult with Council
250m - 2,500m <sup>2</sup>	most houses, long driveways, commercial developments, small subdivisions, small medium density housing, small civil works	Erosion and Sediment Control Plan
>2,500m <sup>2</sup>	large subdivisions, large medium density housing and large civil works	Soil and Water Management Plan including calculations relating to the need for a sediment basin

An Erosion and Sediment Control Plan can vary depending on the complexity, scope and nature of the development, with more detailed plans and associated documentation being required for major proposals which necessitate disturbance to soil.

### B8.1 Erosion and Sediment Control Plans

The Erosion and Sediment Control Plan shall include but not be limited to:

- a recognised scale, appropriate to the site
- a locality plan showing site boundaries and roads
- existing vegetation including what is to be retained
- existing and proposed site drainage, including any dams or artificial wetlands to be used
- contours and slope gradient – with particular attention being given to slopes of greater than 10%
- nature and extent of proposed earthworks, including cut and fill
- location of roads, driveways, access-ways and all impervious surfaces
- location of stockpiles
- erosion control measures
- sediment control measures
- details of site revegetation
- outline of the maintenance program for erosion and sediment control measures
- name of person responsible for implementing the plan
- supporting information may be required to be submitted with the Plan detailing:
- any areas that may have the potential for serious erosion or sedimentation and the proposed management details
- a brief description of the overall site rehabilitation program

### B8.2 Soil and Water Management Plan

A Soil and Water Management Plan is to include all the matters required for an Erosion and Sediment Control Plan as well as the following information (as relevant):

- location of lots, public open space, stormwater drainage systems, schools, shopping/community centres
- the location of land designated or zoned for special uses
- existing site contours
- the location and general diagrammatic representations of all sediment control measures
- location and engineering details with supporting design calculations for all necessary sediment basins
- location and basic details of any other facilities proposed to be included as part of the development or works, such as constructed wetlands, gross pollutant traps, trash racks or trash collection/separator units or water sensitive stormwater treatment measures (such as bio retention systems, vegetated swales and infiltration measures)

The above plans should be prepared in accordance with the NSW Landcom publication titled *Managing Urban Stormwater: Soils and Construction Vol. 1 4th ed. March 2004 (Blue Book)*. Where there is an inconsistency between this DCP and the Bluebook, the Blue Book shall prevail

### Objective

- a) To minimise the erosion and sedimentation arising from land use and development
- b) To intercept and contain eroded material from building and development sites within the boundaries of the site
- c) To minimise the potential for sediment and silt laden waters coming off the site or contributing to water courses
- d) To minimise soil loss from development through effective site management practices that reduce windblown soil loss
- e) To ensure prompt and effective stabilisation of disturbed lands by appropriate revegetation strategies

### Control

#### B8.2.1 Preparation of the plan

- 1) Plans are to be prepared by a person qualified and experienced in the management of soil and water

#### B8.2.2 Site preparation

- 1) Sediment control measures must be installed prior to commencing any excavation or earth moving
- 2) Where vegetation exists on the site, buffer zones of vegetation should be retained along the boundaries of the site, particularly those adjacent to waterways and street gutters

#### B8.2.3 Sediment Control measures

- 1) Sediment fences down slope of the disturbed site are to be installed, either at the boundaries of the site or at the edge of the disturbed site, with the returns upslope. Fencing is to be placed around the low side of building sites, particularly near flow lines, to filter sediment from runoff water. The fences must be regularly inspected and sediment removed to ensure the fences remain effective
- 2) Upslope diversion devices, such as perimeter banks or barriers shall be installed to reduce the volume of stormwater reaching any disturbed areas
- 3) On rural properties, farm dams proposed to be built as part of the subdivision or artificial wetlands are to be constructed in the initial stages so that they may act as sediment retention ponds during the construction phases. During construction, the dam should preferably be kept empty between storm events
- 4) Cut and fill should be kept to a minimum, and shall be not greater than a cut of 1 metre

- 5) Barriers are required to trap coarse sediment at all points where stormwater leaves the site to stop it washing into gutters, drains and waterways
- 6) Adjacent streets and gutters are to be swept regularly to keep them clean and the removal of accidental spills of soil or other material shall occur immediately. Hosing of streets and gutters is not permitted at any time during construction
- 7) Kerbside vegetation and other vegetation surrounding the development site shall be maintained in a healthy state so it can function as an additional filter strip for sediment
- 8) Topsoil removal shall be limited to the construction site only. Once topsoil is removed, it is to be stockpiled for reuse in landscaping
- 9) Revegetation of sites shall occur as soon as possible to prevent soil erosion. Excavated top soil should be reused

#### B8.2.4 Wash out Areas

- 1) A designated washout area shall be provided for waste water generating activities such as tile cutting, paint and other trade equipment. This area shall be located away from drainage lines and the street gutter and be regularly cleared in an appropriate manner
- 2) All runoff is to be intercepted by a sediment fence, straw hay bales or other suitable filter device to prevent stormwater pollution

#### B8.2.5 Stabilised Entry/Exit Point

- 1) A single vehicle entry/exit is to be constructed out of 40mm blue metal aggregate or recycled concrete to a depth of 150mm to minimise tracking of sediment onto roads

#### B8.2.6 Position of stockpiles

- 1) Stockpiles of building materials shall be located away from drainage paths and uphill of sediment barriers
- 2) No stockpiles are to be located on nature strips, footpaths, roadways, access ways, public land or within drainage lines
- 3) Sediment fences shall be placed around the stockpile(s)

#### B8.2.7 Air Pollution

- 1) Stockpiles of sand and soil and disturbed areas shall be located in a sheltered position where possible and covered or watered to prevent soil being blown offsite

#### B8.2.8 Inspection and Maintenance

- 1) Erosion and sediment control measures must be inspected regularly being:
  - daily when work is occurring on the site
  - weekly when work is not occurring on the site
  - immediately after a rainfall event to ensure the controls are functioning and any sediment removed
- 2) All erosion and sediment control measures shall be maintained until construction is complete and the site is stabilised

#### B8.2.9 Rural Roads

Roads are the single largest source of sediment movement from rural subdivisions, both during the construction phase and in the longer term.

- 1) A Soil and Water Management Plan is required for all rural roads. Refer to section B7 Engineering requirements in this DCP for more detailed requirements in the design and construction of roads
- 2) Temporary erosion and sediment controls, such as sediment fences, must be installed and inspected by the certifier prior to work commencing and are to be maintained during construction and through the defects liability period



- 3) All disturbed areas shall be topsoiled and revegetated

### B8.2.10 Penalties for non-compliance

Failure to implement or maintain adequate sediment and erosion control on a site can result in regulatory action, which may include the issue of fines.

#### Further information

Illustrations of different types of sediment control devices can be found in the NSW Landcom publication titled *Managing Urban Stormwater: Soils and Construction Vol. 1 4th ed. March 2004 (Blue Book)*.

## B9 Flood Planning

Parts of the urban areas of Braidwood, Bungendore and Captains Flat are all affected by flooding. Other areas of the local government area are also susceptible to flooding but have not been studied by Council. These areas, however, still require consideration of flooding. Clause 5.21 of *QPRLEP2022* requires that proposed development consider flood hazard.

### Objective

- a) To comply with the objectives of Clause 5.21 of the *QPRLEP2022*
- b) To ensure the impacts of the full range of floods, up to and including the probable maximum flood, are considered when assessing development of flood prone land
- c) To take account of social, economic and ecological factors in relation to flood issues
- d) To ensure development is in accordance with the principles contained in the *Floodplain Development Manual*, issued by the NSW Government
- e) To only permit development where the full potential risk to life from flooding can be managed for all floods up to and including the Probable Maximum Flood.
- f) To minimise the impact of flooding and flood liability on individual owners and occupiers
- g) To ensure development and construction materials are compatible with the flood hazard

### Development application requirement

A comprehensive flood report may be required with any development application on land identified as being at or below the flood planning level, this should be discussed with council prior to submitting a development application. The flood report shall be prepared by a suitably qualified and experienced engineer recognised under the National Professional Engineers Register in this field. The full name of the person who prepared the report, relevant qualifications and registration number are to be provided on the front page of the report. The report shall:

- be undertaken in accordance with the NSW *Floodplain Development Manual*
- include a description of the watercourse or drainage system that is relevant to the site, whether located on, adjacent to or remote from the development site
- consider the full range of flood events up to and including the probable maximum flood
- include site plans and cross-sections of appropriate scale and detail to allow assessment of the development
- show flood levels for the probable maximum flood, 1%, 5%, 10% and 20% annual exceedance probability (AEP) flood events for both pre and post development scenarios
- show flood velocities and vectors for the 1% AEP pre and post development scenarios
- show provisional flood hazard categories for the post development scenario determined in accordance with the *Floodplain Development Manual* and including consideration of obvious issues related to evacuation
- show hydraulic categories across the site for the pre and post development scenario
- include all assumptions, calculations and modelling outputs of the flood investigation

- include a section and modelling considering impacts on adjacent properties and the wider floodplain
- include any other information necessary to allow the development to be appropriately assessed.

In addition, if the development includes construction of buildings at or below the 1% AEP flood event, a report from a qualified structural engineer is to demonstrate that all buildings are capable of withstanding the hydraulic loads induced by flood waters. The assessment shall consider the effects of debris and buoyancy.

## Control

### B9.1 General

- 1) Consideration will be given to development on land below the flood planning level, but only if it is not located within a floodway or high hazard area as stated in the Floodplain Development Manual
- 2) Any portion of any building that may be subject to the effects of flood waters is to be built from flood compatible materials (see Appendix B for suggested materials)
- 3) All services associated with the development are to be adequately flood proofed
- 4) No on-site sewage management system shall be located within a flood planning area

### B9.2 Residential – new development

- 1) Developments designed to cater for vulnerable sections of the community (such as seniors housing) are not suitable for land identified as being a Flood Planning Area
- 2) Floor levels of habitable rooms are to be at or above the Flood Planning Level
- 3) Flood safe access and emergency egress for all flood events up to the 1% AEP event plus 500mm freeboard is to be provided
- 4) Residential garages are to be at or above the 1% AEP level. Where this is impractical, garages are as to be as high as practical and electrical points are to be at or above the Flood Planning Level

### B9.3 Residential development – extension to existing dwelling

- 1) Extensions with a floor area up to 35 m<sup>2</sup> may be approved with floor levels below the 1% AEP flood level if the applicant can demonstrate that:
  - no practical alternative exists, and
  - the level of hazard will not increase
- 2) Extensions with a floor area up to 50 m<sup>2</sup> may be approved with floor levels at or above the 1% AEP flood level but less than the Flood Planning Level if the applicant can demonstrate that:
  - no practical alternative exists, and
  - the level of hazard will not increase

### B9.4 Non habitable extensions or alterations, outbuildings and swimming pools

- 1) Any portion of a building that may be subject to inundation is to be built from flood compatible materials
- 2) All electrical services shall be adequately flood proofed
- 3) All flood sensitive equipment shall be located above the 1% AEP flood level

### B9.5 Industrial and Commercial Development

- 1) Floor levels at or above the Flood Planning Level or the buildings are to be flood proofed to at least the Flood Planning Level
- 2) Flood safe access and emergency egress for all flood events up to the 1:100 ARI event plus 500mm freeboard is to be provided

- 3) All flood sensitive equipment shall be located above the 1% AEP flood level

### B9.6 Rural uses

- 1) New buildings and extensions to existing buildings for rural uses that are below the 1:100 ARI flood level (other than a residential building) will be considered on their merits subject to:
  - The proposed development not increasing the flood hazard or flood damage to other properties or adversely affect other properties during times of flooding, and
  - The proposed use and the potential for property loss
- 2) Areas to be used to store potential pollutants and hazardous materials are to be constructed above the 1% AEP flood level.

### B9.7 Alterations to the Natural Surface Level of Land

- 1) Proposed earthworks are not to increase the flooding hazard or flood damage to other properties or adversely affect other properties during flood events

### B9.8 Fencing

- 1) Fencing construction and materials are to allow floodwaters to equalise on either side
- 2) Fencing construction and materials are to safely allow floodwaters or debris to pass

## B10 Heritage – European (non-Indigenous), Aboriginal (Indigenous) and Natural

Heritage consists of those places and objects that we as a community have inherited from the past and want to hand on to future generations.

Our heritage gives us a sense of living history and provides a physical link to the work and way of life of earlier generations. It enriches our lives and helps us to understand who we are today.

The former Palerang local government areas heritage is diverse and includes buildings, objects, monuments, Aboriginal places, gardens, bridges, landscapes, archaeological sites, relics, streets, industrial structures, routes of human movement, cultural landscapes and a conservation precinct.

The controls relating to 'Braidwood and its setting' are contained in the *Braidwood Development Control Plan (BDCP) 2006*.

### B10.1 European Heritage

Heritage items have special qualities that make them significant and in undertaking development care needs to be taken to ensure that the features or characteristics that make the item significant are not compromised by change. Heritage items are mostly buildings but can include structures, places or relics.

Council maintains a database of heritage items included in the *QPRLEP2022*. Most items have an inventory record that identifies their significance and may also include historic photographs along with other information. This should be considered where the development of a heritage item or a place in a conservation area is being proposed. Heritage studies for Bungendore and Braidwood and its surrounds are available for viewing at Council's administrative offices.

Council provides a free heritage advisory service to assist property owners and developers determine how heritage controls apply to their proposed development. Applicants are strongly advised to discuss their development proposal with Council's Heritage Advisor or a professional with specialist heritage training and experience prior to lodging a development application.

Heritage items are listed in Schedule 5 of the *QPRLEP2022*. Additionally, there are numerous items on the NSW State Heritage Register. This DCP should be read in conjunction with clause 5.10 Heritage Conservation of the *QPRLEP 2022*.

### B10.1.1 Suggested colour schemes

Suggested colour schemes are contained in Appendix C of this DCP.

### B10.1.2 Maintenance of heritage items

Maintaining heritage items is the most practical way to protect the significance and history of a building, work, relic, or place. Common maintenance tasks include:

- ensuring roofs are secure and without gaps or broken tiles that will allow water to penetrate
- ensuring roof and site drainage systems are operating efficiently, check conditions of gutters, drainpipes and drains regularly and keep clear of debris
- regular monitoring of walls and cladding for structural soundness and protection from water, wind, dust and vermin
- keeping trees and branches pruned and clear of roof and walls
- weeding and pruning plants and repair significant garden structures
- regularly checking and repairing garden fences
- maintaining adequate under floor ventilation
- avoiding locating garden beds against exterior walls. If unavoidable, ensure the ground level is maintained below the level of the damp course and any wall ventilators or weep holes

### B10.1.3 Works that may not require approval and exempt development

Some works do not require development consent (this does not include state listed items), including many that are required to maintain a property. This can include the following:

- maintenance
- repainting surfaces that are already painted in the same colour or a colour in keeping with the heritage significance. if in doubt about appropriate colours seek advice from Council's Heritage Advisor
- repairs to joinery, roof and wall framing
- wall repairs, underpinning, repointing and installation of a damp proof course
- replacing or establishing gutters and down pipes
- roof repairs, replacement of chimney pots, repointing tiles, replacing roof sheeting or tiles on a like for like basis
- reglazing on a like for like basis
- repairs to veranda tiling, decking and posts
- repairs to boundary walls and fences
- repairing stonework and plasterwork
- general maintenance of heritage gardens (e.g. pruning or replanting of original species)
- non-structural internal alterations of locally listed heritage items which do not have their interiors listed as being significant

If the works proposed are minor, a written description of the proposed works including details of materials to be used and materials to be replaced, paint colour and other relevant details should be sent to Council. Council will review the proposed works and will provide advice that it is satisfied the proposed works are minor and that development consent is not required.

### Exempt development

*State Environmental Planning Policy (Exempt and Complying Development Codes) 2008* allows certain minor development as exempt development. Development consent is required if the development standards for heritage items specified in the *State Environmental Planning Policy (Exempt and Complying Development Codes) 2008* cannot be met.

### B10.1.4 Works requiring development approval

In most instances alterations and additions to a heritage listed item require the lodgement of a development application and an assessment of the impact of the proposal on the heritage significance of the place, including historic, architectural, aesthetic, cultural, social, technological, landscape, archaeological or other features of the place including its setting.

Council offers a free heritage advisory service and can assist with preliminary advice on proposals affecting heritage items and sites in the vicinity of heritage items.

#### Objective

- a) To ensure that a building's historic character and heritage significance is addressed in the design stage

#### Control

- 1) Copies of relevant parts of the inventory sheets in Council's heritage data base are to be included with the development application. Council may require the preparation of a Built Heritage Impact Statement (requirements are outlined at the end of this section). Proponents should seek advice from Council's Heritage Advisor as early as possible to determine the need for a heritage impact statement

### B10.1.5 Matters for Consideration

#### B10.1.5.1 Building Style and Character

##### Objective

- a) To ensure that a building's significance, including style and character of all elevations and contributing buildings, are appropriately managed when alterations and additions are planned

##### Control

- 1) Architectural and design elements that contribute to the heritage significance of the item or surrounds are to be maintained and respected in any development
- 2) Alterations and additions including contemporary architectural designs should not compromise, dominate or detract from a place's significant heritage attributes including its style and character, form, detail, finish and setting
- 3) Additions to buildings should not appear larger or more dominant than the original building when seen from the public domain
- 4) Extensions should respect the form, symmetry and location on the block of the existing dwelling or structure

#### B10.1.5.2 Alterations to significant elevations, and location of additions

A historic building's front elevation is often its most important façade, having been designed with streetscape presentation in mind. It is usually well composed and detailed and can reveal considerable information about the building's age, style, scale and resources available at the time of construction and this should be respected in the design of new development. A heritage item is rarely only significant for the appearance of its front elevation, and other elevations can also be important in understanding the item. In some instances previous alterations may have added an additional layer of heritage value.

##### Objective

- a) To encourage management of all elevations to ensure that they are in keeping with the heritage value of the whole building
- b) To locate additions so that the front façade of the building retains its integrity and remains dominant

## Control

- 1) Additions to the front of a building will only be considered where original details are being reinstated which have previously been removed or where the alteration is to a previous unsympathetic addition and will enhance the building's character
- 2) Additions to the side of buildings should be set back from the front face by a minimum of 900 mm
- 3) The front elevation of a listed building (and any other elevation considered to be important to the significance of the item) should not be substantially altered except for:
  - i. restoring the facade to its original form, detail and condition.
  - ii. removing previous alterations or additions that are unsympathetic or detract from the heritage significance of the place
  - iii. minor alterations that are in keeping with the form, style and character of the place
  - iv. general maintenance
  - v. extensions should not prevent vehicle access to the rear of the lot.
  - vi. extensions should respect the form, symmetry and location on the block of the existing dwelling or structure and the relationship between the existing dwelling and any secondary buildings on the site or buildings in the vicinity

### B10.1.5.3 Building Scale

In general, buildings may be extended by:

- increasing the bulk or form of the existing building at ground level or
- constructing a linked pavilion to the rear of the main dwelling

The former may be more appropriate where the extension is not large and will not distort the scale of the original. Extensions of this type should closely follow the detail of the original building with ridgelines of the addition no higher than the original.

The pavilion model is suited to extensions to small cottages, or where minimal disturbance of the original fabric is required. The pavilion model enables a modern interpretation of the original, generally using modern materials and details that reflect historic scale and roof pitch, and is suitable where the new ridgeline will be higher than the original.

## Objective

- a) To ensure that the scale of new work is compatible with, and does not dominate, that of the original building or its setting

## Control

- 1) Extensions should appear to be of a lesser scale than the original
- 2) The height of extensions should be no higher than the primary existing ridgeline
- 3) The vertical and horizontal scale of walls should be consistent with that of the existing building
- 4) Large additions or those of a differing scale should adopt the "pavilion" model of additions

Figure 3 The primary roof form should remain dominant with new additions set back and having lower ridge height

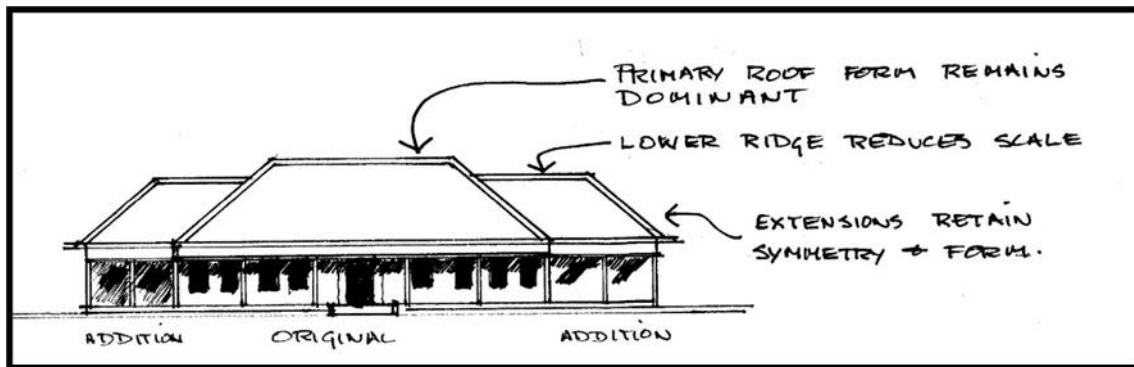
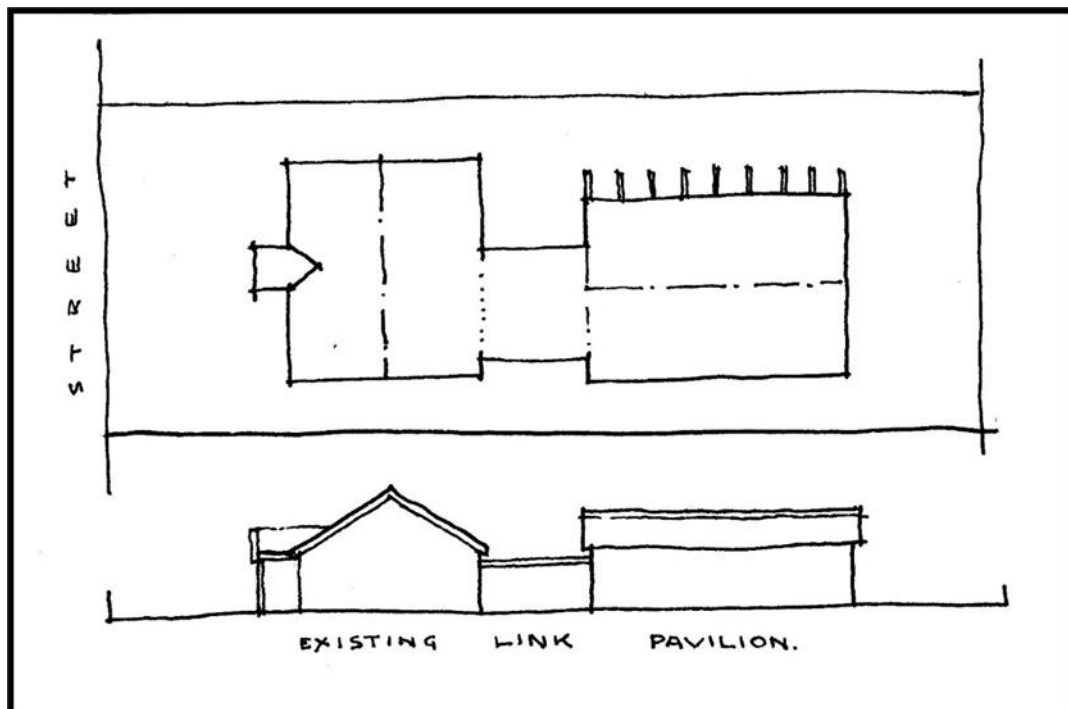

Figure 4 Large additions are often best done as a pavilion that is linked back to the original structure



#### B10.1.5.4 Height of additions

Second storey additions to historic buildings are rarely if ever satisfactory in terms of retaining historic style and proportion. Two-storey additions will only be considered if abutting an existing two-storey structure and Council is satisfied that the addition will not harm the heritage significance of the item or the streetscape.

#### Objective

- a) To allow for two storey additions only in those situations where it is appropriate for the historic style and form of the buildings and there will not be an adverse impact on historic scale, character, form streetscape or other aesthetic value

#### Control

- 1) Extensions are to be a maximum of a single storey except where:

- new work will have minimal effect on the streetscape
- the extension is to an existing two storey structure; or
- the extension consists of the creation of an attic within existing roof space; or
- the extension is sited behind an existing building and will not be readily visible above the ridge of the building when viewed from the public domain

#### B10.1.5.5 Roof form, scale and material

The original roof form is almost always a dominant element of an historic building's character. The pitch, form and materials of the roof are key elements to be considered when ensuring that additions are sympathetic to the original building.

#### Objective

- a) To ensure that extensions are sited to minimise the impact on existing roofs
- b) To ensure that the appearance of a roof is consistent with a building's historic character

#### Control

- 1) New roofs to additions are to be designed so that the original roof remains dominant.
- 2) New roofs shall utilise the existing pitch, form and material of the original roof where possible. The pitch of skillions are to be adjusted to the circumstances of the new extension
- 3) New roofs shall be appropriate to the style and period of the house
- 4) Alterations to existing rooflines shall not be higher than the original topmost ridgeline. In these circumstances, the pavilion style extension should be used
- 5) Pavilion-style extensions are to be used when the existing roof form is intact and contributes to the item's heritage significance or when a contemporary-styled extension is proposed, or where a historic roof would have to be substantially altered to accommodate an extension
- 6) The scale of roof extensions shall appear to be less than that of the original roof. The scale of large roofs can be reduced by the addition of extra hips and ridges
- 7) Garage roofs are to have lower ridge and eave heights than the parent building
- 8) The reinstatement of historic materials such as timber shingles, short sheets of corrugated galvanised steel and 'ogee" profile gutters, particularly where photographic or other evidence indicates these were once used, is to be incorporated where possible
- 9) Modern roofing profiles, such as 'Kliplock' and ribbed decking, shall not be used where they will be visible from the public domain
- 10) Skylights are to be located within the roof plane and preferably on roofs that are not readily visible from the public domain
- 11) Protruding skylights shall not be readily visible from the public domain



Figure 5 Additions should not compromise the form of the original

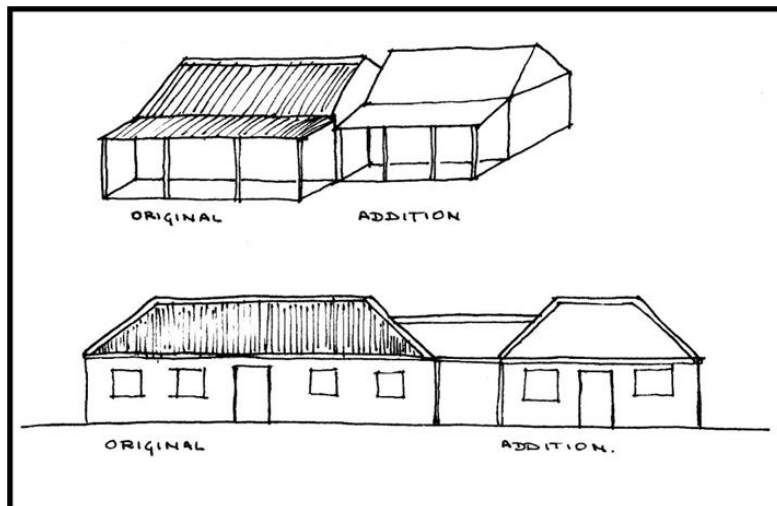

#### B10.1.5.6 Attics and dormer windows

Attic rooms are common in many early cottages and often contain a small window in the end gable, and possibly one or more dormer windows in the roof plane.

#### Objective

- a) To allow for the adaptive use of attic spaces while retaining historic roof proportions
- b) To ensure that the configuration of dormer windows is consistent with historic evidence

#### Control

- 1) The number of dormer windows in a roof plane should be in keeping with other historical examples
- 2) On front elevations each dormer should be no more than 1200 mm wide, unless historical evidence relevant to the property supports an alternative configuration
- 3) Dormer windows should not be grouped or arranged so that they dominate the roof plane
- 4) The existing roof shall not be re-pitched to accommodate the attic

Figure 6 Attics should be of a traditional style and not dominate the roof

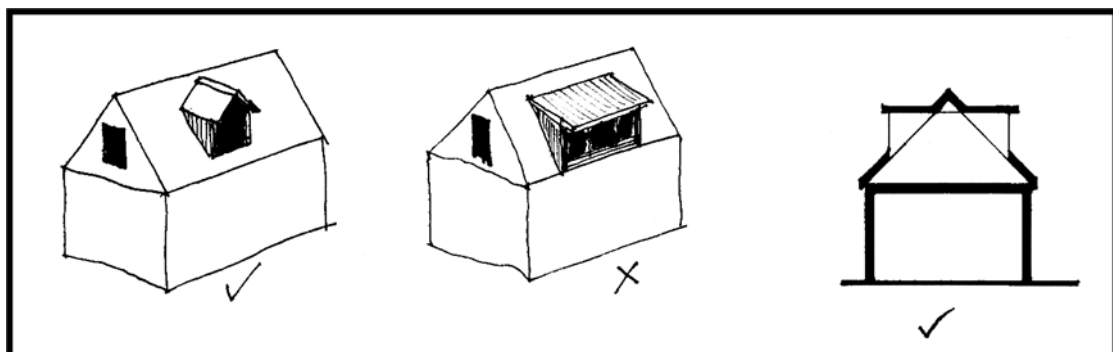

### B10.1.5.7 Walls

New building materials should be sympathetic to the original. It is not always possible (nor desirable) to match early profiles and details, but similarly proportioned and textured contemporary materials should be used wherever possible. Materials and colours of the existing house or that of surrounding buildings need not be copied, but used instead as a point of reference. Modern materials can be considered for use if their proportions and details are harmonious within the local context.

#### Objective

- a) To ensure that walls continue to reflect historic characteristics

#### Control

- 1) Surviving weatherboard walls are to be maintained in situ
- 2) If replacement is necessary, then Australian Hardwood weatherboard walls should be used. Western-Red Cedar weatherboards are not appropriate replacements and should not be used
- 3) Weatherboards must not be replaced by brick veneer. The use of lightweight cladding systems over existing walls, such as plastic or metal 'weatherboards' is not appropriate
- 4) Brick walls that have not been painted should remain un-painted
- 5) Brick walls that have never been rendered should remain un-rendered
- 6) Repairs to brick walls should be made using lime-rich mortar, not cement-rich mortars, which can cause serious long-term damage to soft nineteenth century bricks
- 7) New bricks should be chosen to blend with the colour and texture of any original brickwork

### B10.1.5.8 Chimneys

#### Objective

- a) To retain the significant visual contribution by chimneys to historic character

#### Control

- 1) Historic chimneys should not be removed unless they are structurally unsound and unable to be restored

### B10.1.5.9 Window and door openings

The scale, proportion and materials used in windows and doors can have a major impact on the success of new work in terms of its impact on the heritage significance of the property and the streetscape.

#### Objective

- a) To retain the important contribution that windows and doors make to listed items and the streetscape, where visible from the public domain

#### Control

- 1) New windows are to be timber-framed with moulding and glazing patterns appropriate for the style of the house
- 2) Where visible from the street, the original window and door arrangements within the wall should be retained, especially on the front elevation. There is more latitude for variation further back on side elevations
- 3) Windows and doors on additions should reflect the external proportion and relationship to the wall as the original and be appropriate for the style of the house
- 4) Contemporary materials such as aluminium framing to windows are not appropriate for heritage items unless in a contemporary styled extension not visible from the public domain

### B10.1.5.10 Verandas

Verandas are important components of many heritage buildings and their retention, restoration and reconstruction is encouraged. Proportions and details vary and were usually carefully designed components of a building's façade. Reconstruction should be based on evidence and closely follow original proportions. Cast iron "lace" was rare and should only be added where it is known to have existed originally.

Decorative details such as timber valances, decorative barge boards and fascias, fluting on columns, veranda pickets etc should generally be based on evidence or in the style of the building's period.

#### Objective

- a) To ensure that verandas continue to make an important contribution to the historic place

#### Control

- 1) Original front verandas are to be retained in all new work
- 2) The reconstruction of lost verandas based on evidence of the fabric or early photographs or drawings is encouraged
- 3) If no evidence is available then reconstructions should be based on the original forms of similar building types
- 4) Existing open verandas should not be enclosed unless there is sound historical or physical evidence that they were originally enclosed

### B10.1.5.11 Finishes

Finishes refer to the surface treatment of the building, and can include paints, lime-washes, oils, exposed face brickwork, exposed and pointed stone work, rendered masonry, unpainted or painted roof iron etc. The type of finish chosen was often a function of design intention, materials, availability of skill and trades, availability of resources and budgets. The finishes are the visible face of the building and play an important part in its perception.

#### Objective

- a) To retain external building finishes that contribute to a place's heritage value

#### Control

- 1) Existing building finishes that contribute to a structure's historic character should to be retained and maintained
- 2) Additions that abut or join onto historically finished buildings are not to compromise the integrity of the original finish, and often work well if designed in an alternative material or finish

### B10.1.5.12 Garages and carports visible from the street

Garages and buggy sheds were generally located to the rear of properties in many historic buildings. It is only in more recent times that garages have been constructed at the front of the lot or under the roofline of the main dwelling.

#### Objective

- a) To reduce the visual impact that new garages can have on heritage buildings and streetscapes

#### Control

- 1) New fully-enclosed garages shall not connect with the dwelling other than through a short, low pitched roof link
- 2) Where garages will be visible from the street they are to be located toward the rear of the property
- 3) Enclosed garages shall not be constructed forward of the dwelling
- 4) Garages and carports shall be of a smaller scale than the dwelling where visible from the street

- 5) Garage and carport design is to be sympathetic to the period of the building, including roof pitch and roof and wall materials and shall not compromise the design or form of the original building
- 6) Prefabricated garages visible from the street shall have a minimum roof pitch of 25 degrees and shall not use modern profile ribbed metal cladding. Traditional mini-orb and custom-orb cladding are suitable

Figure 7 Garages should not dominate the streetscape and should be of a style and form that is appropriate for the house

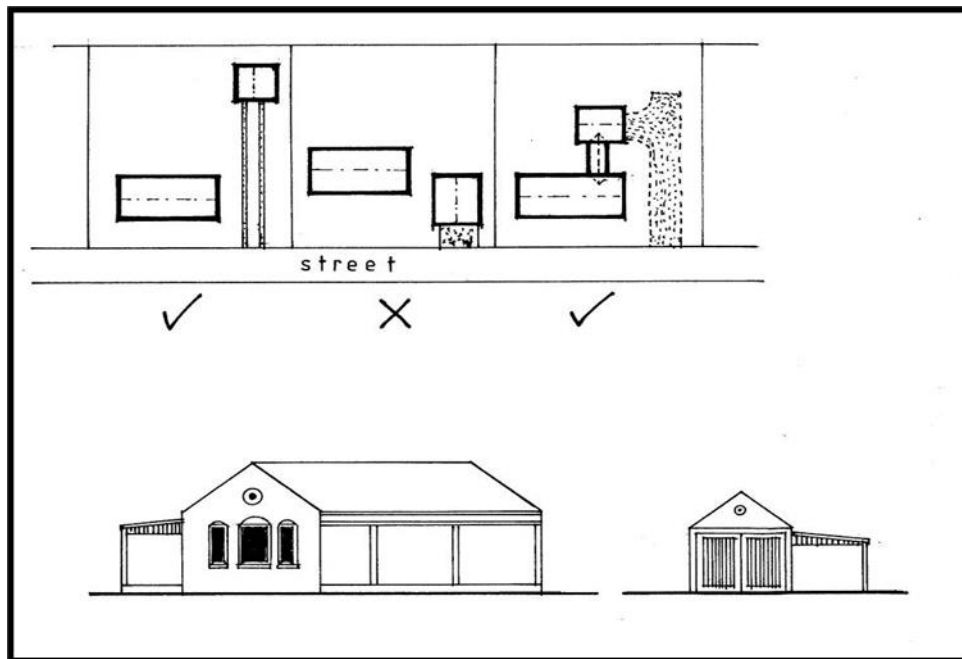

#### B10.1.5.13 Adaptive re-use of heritage items

Keeping and re-using historic buildings has long term benefit for communities that value them. The adaptive re-use of a building can restore and maintain buildings so that they can continue to be used, rather than falling into disrepair and neglect.

#### Objective

- a) To support innovation and new ideas in the selection of an appropriate use of a heritage item
- b) To ensure the heritage significance of heritage items is the starting point for the change of use and design development
- c) To encourage recycling of the fabric where the original design use is redundant
- d) To ensure heritage significance is retained while ensuring compliance with the *Building Code of Australia*

#### Control

- 1) Proposals for re-use are to demonstrate the following:
  - compliance with the *Building Code of Australia* addressing the performance based design solutions if necessary
  - alteration of significant fabric and detailing is minimised
  - alterations to the interior of the heritage building minimises the effect on the exterior of the building
  - the significant original use is interpreted

- the original crests, dates, logos and building names are retained
- the history of the building is interpreted on the site in the form of interpretation panels, artefact and photographic displays, in situ retention of machinery and signage, or artistic interpretation

### B10.1.5 Demolition of a listed heritage item

The demolition or partial demolition of a state heritage listed item is classified as Integrated Development under Section 91 of the NSW *Environmental Planning and Assessment Act 1979* and requires the consent of the Heritage NSW. The demolition of locally listed heritage items requires the consent of Council.

#### Objective

- a) To retain heritage items

#### Control

- 1) Typically demolition will only be permitted where:
  - the building is so structurally unsound as to be beyond reasonable economic repair. The development application must include a professional structural assessment in support of demolition or
  - the existing condition poses a significant health or safety risk that is beyond reasonable economic repair. The development application must include a professional structural or health assessment demonstrating that conservation is not a practical option or
  - in the opinion of Council, the integrity of the built form and street elevations of an original building has been extensively and irreversibly diminished by unsympathetic alterations and additions.
- 2) Except where a building presents an immediate threat to public safety, the total demolition of an identified dwelling shall not be permitted unless a development application for a replacement dwelling has been approved.
- 3) The partial demolition of original external building fabric of identified dwellings shall only be permitted in the context of permitted alteration or additions.
- 4) Alteration to, or demolition of, internal building fabric of identified dwellings may be permitted provided the external building fabric of the dwelling is not adversely affected.

### B10.1.6 New development in the vicinity of heritage items

New development has the potential to impact on historic buildings and streetscapes by virtue of scale, location, appearance and landscaping. A good reference is *Design in Context: Guidelines for Infill Development in the Historic Environment*, available from Heritage NSW.

#### Objective

- a) To ensure new development harmonises with the existing streetscape and heritage items built form
- b) To ensure new development does not block views to, or compromise the appreciation of significant buildings

#### Control

- 1) Buildings shall be appropriate to the character of the streetscape or context.
- 2) New buildings shall be of a similar height or less than surrounding buildings.
- 3) New buildings shall not obstruct views (including oblique views along the street) of significant buildings.
- 4) New buildings shall not visually dominate the streetscape or roofscape of the surrounding area.

- 5) New buildings shall be set back or further away from the significant building if it is likely to have an adverse impact on a heritage building by virtue of scale, location or appearance.
- 6) New buildings with visible side elevations shall be articulated if greater than 15 metres in length. The articulation can take the form of a rebate in the wall, possibly in combination with a full height change of wall material.

Figure 8 Long-side walls are to be articulated

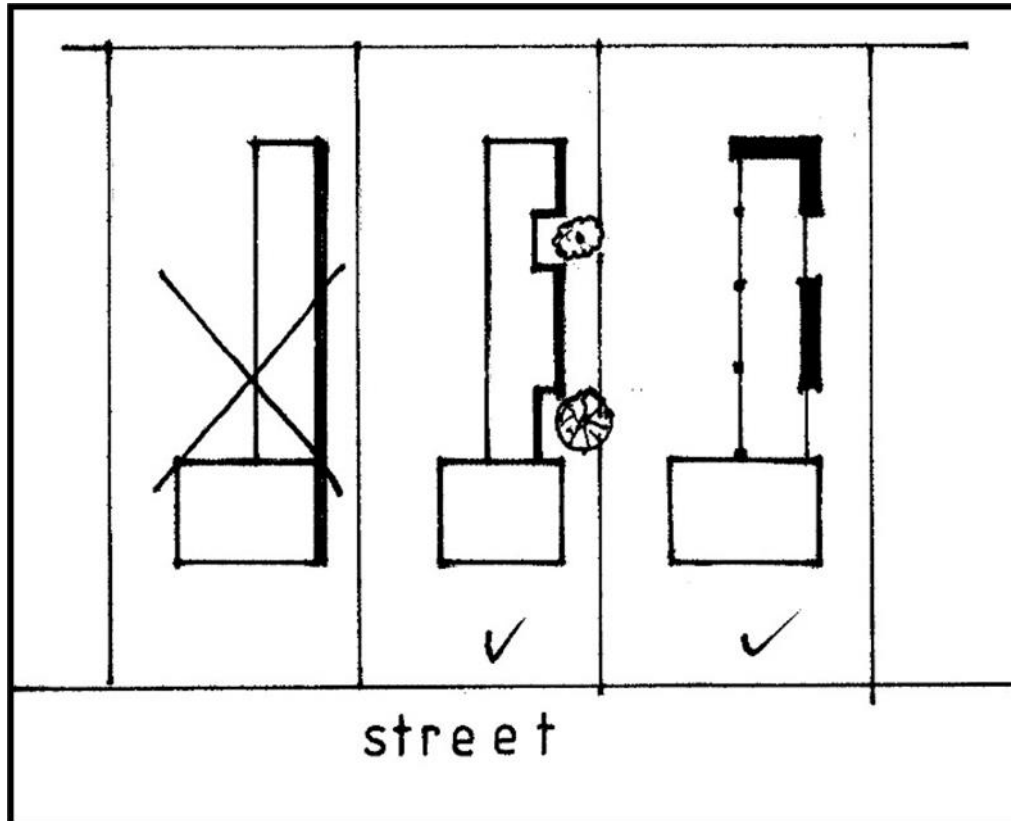

- 7) New development may "borrow" architectural language or design from early historic or contributory architectural buildings, such as roof pitch, corrugated iron roofing or weatherboard walls.
- 8) New development may interpret traditional design concepts in a modern way, and do not have to copy existing buildings.
- 9) Where larger scale new developments are proposed a building and streetscape character analysis, streetscape elevation, and definition of suitable envelope, is to be prepared and discussed with the heritage advisor prior to undertaking detailed design.
- 10) Where a structure is unable to achieve a suitable design standard, for example because of its utilitarian or specific nature, it is to be lower, set back from adjacent structures and incorporate suitable screening.

### B10.1.7 Garages in the vicinity of heritage items

Whether under the same roof or separate, garaging should not have a visually dominant impact on the streetscape and should be designed as a "lesser" element in the composition of a building façade.

#### Objective

- a) To ensure that garages do not dominate the streetscape

## Control

- 1) Attached garages to new dwellings should be set back a minimum of 1m from the front face of the dwelling.
- 2) The roof form of a garage attached to a new dwelling should not be a continuation of the main roof, but rather be articulated to reduce its scale and bulk.

Figure 9 Garages are to be of a lower scale and set back from the front of the dwelling

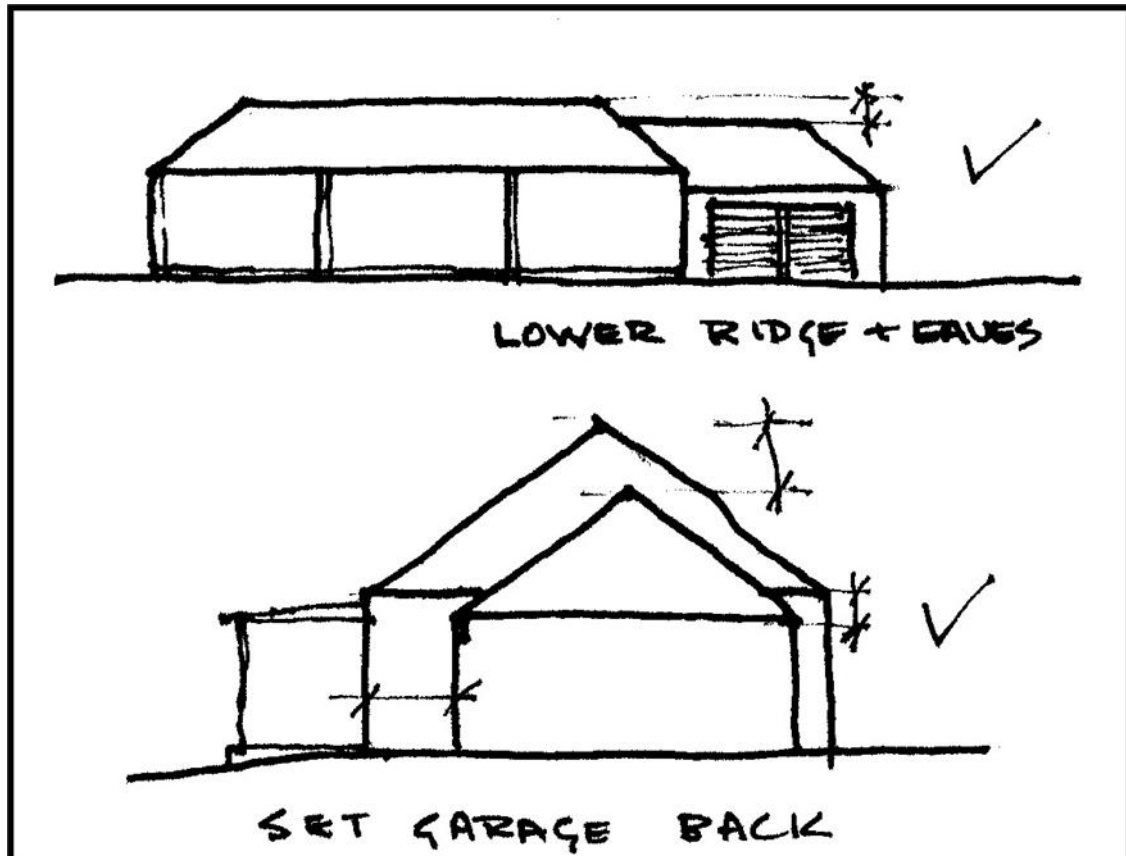

## B10.1.8 Requirements for a Built Heritage Impact Statement

### Objective

- a) To obtain sufficient information to enable consideration of the impact of the development proposal

### Control

- 1) A Built Heritage Impact Statement is to be provided with a development application in the following circumstances:
  - where alterations or additions, demolition or a change of use are proposed in relation to a heritage item listed in the *QPRLEP2022* or on the NSW State Heritage Register, or
  - where development is in the vicinity of, or has the potential to impact upon a heritage item.
- 2) The Built Heritage Impact Statement is to include the following:
  - the qualifications and experience of the author
  - the heritage attributes of an item

- where the development will be “in the vicinity” of a heritage item, a site plan showing the proposed development as it relates to the heritage item and any principal features
- how the heritage values will be managed
- a statement indicating the effects of the proposed development on the heritage item
- comments on any adverse impacts and why there are no satisfactory alternatives
- a plan of the heritage item as it exists at a scale of 1:100 or 1:50
- a site plan showing the location of the item in relation to the boundaries of the site and buildings on adjoining land and the principal features of the site
- a description of the item with information about its history, approximate age, details of construction and its features
- a statement of the heritage significance of the item
- details of the proposed changes to be made to the item, or the development of the land, and their effect on the heritage item
- photos or film of the item.

Further information can be found in the document Statements of Heritage Impact, Heritage NSW [www.heritage.nsw.gov.au](http://www.heritage.nsw.gov.au)

## B10.2 Aboriginal Heritage

Aboriginal objects are physical evidence of the use of an area by Aboriginal people. Aboriginal objects include:

- physical objects, such as stone tools, Aboriginal –built fences and stockyards, scarred trees and the remains of fringe camps
- material deposited on the land such as middens
- the ancestral remains of Aboriginal people

Aboriginal heritage also includes places associated with stories of traditional activity known to local Indigenous people. The places may include natural features such as large rock formations, waterholes and particular shaped trees

Aboriginal sites (both known and unknown) and areas of significance are an important part of Australia’s cultural heritage. The sites and areas of significance provide a direct link for Aboriginal people with their culture. It is important to preserve as many of them as possible.

There are a number of known Aboriginal sites in the local government area however, as the LGA is large and many areas are difficult to access, the majority of the area has not been surveyed for either sites or areas of significance. Consequently, some development will require an assessment for Aboriginal cultural heritage.

The *NSW National Parks and Wildlife Act 1974* protects Aboriginal objects and places in NSW. It is an offence under the *NSW National Parks and Wildlife Act* to disturb, excavate land for the purpose of discovering an Aboriginal object, knowingly destroy, damage or deface an Aboriginal object or Aboriginal place.

### Objective

- a) To identify Aboriginal heritage at the earliest possible stage in the development process

### Control

- 1) All development will require the consideration of Aboriginal heritage. However, it is recognised that there are areas of Palerang that are more likely to contain Aboriginal heritage, for example areas adjacent to watercourses.



- 2) All development applications except those where the area has been heavily disturbed (for example an area covered with bitumen or concrete) or where an archaeological report has been previously undertaken on the site will require evidence of a search of the NSW register known as the Aboriginal Heritage Information Management System (AHIMS) (see [www.heritage.nsw.gov.au](http://www.heritage.nsw.gov.au)). Note: The majority of the former Palerang LGA has not been surveyed for Aboriginal heritage objects so objects may exist on a parcel of land even though they have not been recorded in the AHIMS database
- 3) The requirement for an Aboriginal heritage assessment should be discussed with Heritage NSW and Council prior to lodging a development application. If an assessment is undertaken, it is to be lodged with the development application
- 4) All Aboriginal heritage assessments should be undertaken by a qualified archaeologist or an accredited person of Aboriginal descent in consultation with the local Aboriginal Land Council(s) and Aboriginal community groups. Refer to the document Aboriginal cultural heritage consultation requirements for proponents 2011 which is available on Heritage NSW website at [www.heritage.nsw.gov.au](http://www.heritage.nsw.gov.au)
- 5) The heritage assessment report must contain as a minimum the following information:
  - a record of consultation with the local Aboriginal Land Council(s) and Aboriginal community groups
  - the qualifications and experience of the author
  - a detailed description of the area assessed and maps of the area
  - the method of assessment
  - evidence of the AHIMS data base search
  - the findings of the assessment
  - if any heritage was located, an outline of the immediate and future management of it.

### B10.3 Natural Heritage

Natural heritage refers to components of the living environment such as land resources, inland water and diverse animal and plant life. There are several sites in LGA which are of high natural heritage value including Lake George and karst areas such as The Big Hole and London Bridge.

#### Objective

- a) To protect items with natural heritage values

#### Control

- 1) Where development will have an impact on areas with a high level of natural heritage, a natural heritage impact assessment must be submitted with the development application
- 2) The natural heritage assessment report must contain the following information:
  - the qualifications and experience of the author
  - a detailed description of the area assessed and maps of the area
  - the method of assessment
  - the findings of the assessment
  - the impact of the proposal on the area of natural heritage, and
  - proposed mitigation or management measures.
- 3) In regard to karst areas, the following should not be impacted by a development proposal:
  - the quality or natural movement of water entering the karst environment
  - the quality or natural movement of air entering the subterranean portion of the karst environment
  - the richness and distribution of native flora and fauna in the karst environment, and
  - the caves or other geomorphological features.

## B11 Social and economic impact assessment

Some forms of development may have a substantial social or economic impact on the location of the development, for example the establishment of an industry employing a large number of people. A social impact assessment considers the likely social consequences, both positive and negative of a development proposal. An outcome of the assessment may be the identification of a need for community, health or education services facilities and services.

Section 4.15 of the NSW *Environmental Planning and Assessment Act 1979* requires the consideration of the social and economic impact of a proposed development. For some development this will require a detailed economic or social impact assessment. The aim of the assessment is to determine the impacts of a proposed development on the social or economic environment.

### Objective

- a) To ensure that a report contains sufficient information to enable Council to determine the impact of the development proposal on the social or economic environment
- b) To ensure that the social or economic impact of a proposal is considered at the development assessment stage
- c) To consider the need for services and infrastructure to assist in addressing the social and economic impacts of a development proposal

### Control

- 1) Economic and social impact assessments are to be undertaken by people with qualifications and experience in this area. For example a person undertaking a social impact assessment should have qualifications in an area of the social sciences. Those undertaking an economic impact assessment should have qualifications and experience in economics
- 2) The economic or social impact assessment report is to contain the following information:
  - the qualifications and experience of the author
  - the boundaries of the assessment
  - the method used including the details of any models
  - the impacts, both short and long term
  - mitigation and management strategies
  - references to the data used.

## B12 Landscaping

The landscaping of development enhances the streetscape and blends new development into the streetscape. Trees provide many social, functional, environmental, economic and aesthetic benefits to the community. Landscaping also provides an effective ‘softening’ of the hard edges of buildings and can be used to reduce the bulk and visual impact of development. Quality landscaping retains significant natural landscape features and mature trees.

Landscaping also has an important role to play in improving environmental conditions such as stormwater and rainwater absorption, and habitat for native fauna. It can help reduce bush fire risks and regulate the amenity of a development through such things as sun shading using pergolas and tree plantings.

Well planned and executed landscaping contributes to the appearance and amenity of the development. Trees and shrubs can also have an important role in the control of sun, noise, and wind, screening of functional spaces such as parking areas and minimising the amount of water running off the property.

Landscaping should be planned and undertaken during the initial stages of the development. Plans should be at a scale of 1:100 or 1:200. For multi-unit housing, commercial and industrial developments and some domestic construction, landscaping details must be included in the development application.

The planting of native vegetation, especially that which is indigenous to the area and Xeriscape gardens (gardens requiring no water other than rain water) is strongly encouraged. The planting of a diverse range of tree species is encouraged. A well-considered mix of exotic species and locally endemic species strengthens our landscape environment for climatic changes into the future. Where an avenue of a single successful or noteworthy species exists, it should be maintained and preserved.

Section 3.5 of this DCP provides development controls in respect of preservation of trees and other vegetation.

### Objective

- a) To enhance the amenity of an area and development and to blend in new development
- b) To enhance the existing streetscape and promote a scale and density of planting that softens the visual impact of buildings
- c) To conserve significant natural features of the site and contribute to the effective management of biodiversity
- d) To retain and provide for mature vegetation, particularly large and medium sized trees
- e) To assist in encouraging vegetation corridors
- f) To promote privacy
- g) To promote energy efficiency by enhancing solar access, shade and reducing heat transfer from concrete drives, roofs and building walls in summer
- h) To provide for the infiltration of water to the water table, minimize run-off and assist with stormwater management
- i) To improve the microclimate conditions on sites and the solar performance of dwellings
- j) To minimize the adverse interaction between trees (living infrastructure) and the built environment.

### Control

- 1) Landscape design should consider usability, privacy and opportunities for social and recreational activities. Neighbours' amenity should also be respected.
- 2) Development on a site is to be located to retain as many of the significant existing trees as practicable.

### B12.2 Planting of trees

- 1) The placement of trees in urban road reserves should be carefully considered as trees may contribute to damage to cables and pipes. Trees may also suffer severe damage in the event of emergency repairs to these services.
- 2) Trees that will grow to a height where they can interact with overhead powerlines should not be planted in the vicinity of powerlines without the advice of an expert. For advice on safe powerline encroachment distances contact the local electricity authority.
- 3) The following is to be considered when tree species are being selected:
  - the proximity of the tree to adjoining properties and the road reserve-once it matures, and
  - the location of the mature tree and its roots to underground services and utilities. Trees should not be planted closer than 3 metres to a building.

### B12.3 Business and industrial land use zones and multi dwellings and residential flat building developments

- 1) All open space is to be landscaped.
- 2) Landscaping should be planned and undertaken at the earliest possible opportunity.
- 3) A landscape plan is to be lodged with the development application
- 4) Plans should be at a scale of 1:100 or 1:200. The planting of native vegetation especially that which is indigenous to the area is encouraged
- 5) Plans must contain the following information:

- dimensions of walls, fencing and paving
  - any balconies, private open space and communal open space
  - plant species and the expected height of species
  - means of watering plants (if there is to be a watering system).
- 6) In the development of a landscape plan, matters such as neighbour privacy and the retention of elements such as natural rock outcrops, bush fire threat, watercourses, indigenous vegetation and mature trees should be included where possible
  - 7) Consideration is to be given to the location and design of the building to enable the retention of existing vegetation and rocky outcrops
  - 8) Landscaping abutting environmental protection areas should consist of local indigenous species to protect bushland and habitat corridors and soften the interface between the natural landscape and the urban environment
  - 9) In developing a landscaping plan, the ‘*Safer by Design*’ principles are to be considered – refer to section B5 Crime Prevention through Environmental Design in this DCP.

## B13 On-site System of Sewage Management (OSSM)

An On-site System of Sewage Management (OSSM) is any system that treats sewage on the site where it is produced, such as a septic tank, composting toilet or aerated treatment system.

Most properties in the former Palerang LGA are located outside the towns and villages and rely on domestic effluent treatment by on-site waste water systems. Under Section 68 of the *NSW Local Government Act 1993*, an approval is required to install, alter and operate an OSSM.

The majority of former Palerang LGA is within a drinking water catchment therefore it is important that systems are appropriately designed and installed.

The guideline *Designing and Installing On-Site Wastewater Systems: A Sydney Catchment Authority Current Recommended Practice (2014)* provides recommendations to design, install, test, operate and inspect the following systems:

- septic tanks
- aerated wastewater treatment systems
- biological filter systems
- composting toilets
- amended soil mounds
- Wisconsin sand mounds
- greywater treatment systems
- absorption trenches and beds
- evapotranspiration absorption beds
- surface irrigation systems
- subsurface irrigation systems

This publication can be found on the Water NSW website:

[www.sca.nsw.gov.au/publications/publications/designing-and-installing-on-site-wastewater-systems](http://www.sca.nsw.gov.au/publications/publications/designing-and-installing-on-site-wastewater-systems)

In assessing the adequacy of all environmental assessments of proposed systems, Council will apply the *Neutral or Beneficial Effect on Water Quality Assessment (NorBE) Guideline* developed by the SCA regardless of the system’s location within the Queanbeyan-Palerang local government area.

*The Neutral or Beneficial Effect on Water Quality Assessment Guideline, Sydney Catchment Authority, (2011)* enables council to decide if a proposed development has a neutral or beneficial effect on water quality.

## Objective

- a) To ensure the prevention of public health risk – sewage contains bacteria, viruses, parasites and other disease causing organisms. Contact with effluent must be minimised or eliminated, particularly for children. Residuals, such as composted material, must be handled carefully. Treated or untreated sewage must not be used on edible crops that are consumed raw.
- b) To ensure the protection of surface waters – OSSM facilities must be selected, sited, designed, constructed, operated and maintained so that natural or artificial surface waters are not contaminated by any flow from sewage or wastewater treatment systems or land application areas.
- c) To ensure the protection of groundwater – OSSM facilities must be selected, sited, designed, constructed, operated and maintained so that unacceptable risks of groundwater contamination do not occur.
- d) To ensure the protection of lands – OSSM facilities should not cause deterioration of land and vegetation quality through soil structure degradation, salinisation, waterlogging, chemical contamination or soil erosion.
- e) To prevent animal health risk - OSSM facilities must be selected, designed, sited, constructed, operated and maintained so that they do not unreasonably interfere with quality of water intended for stock watering.
- f) To protect community amenity – OSSM facilities must be selected, designed, sited, constructed, operated and maintained so that they do not unreasonably interfere with amenity. Consideration should be given to aesthetics, odour, dust, vectors and excessive noise.
- g) To ensure the conservation and reuse of resources – the resources in domestic wastewater (including nutrients, organic matter and water) should be identified and utilised as much as possible within the bounds posed by the other performance objectives. Water conservation should be practiced and wastewater production should be minimised.
- h) To encourage ecologically sustainable development – OSSM facilities should be selected, sited, designed, constructed, operated and maintained using, conserving and enhancing the community's resources so that ecological processes, on which life depends, are maintained, and the total quality of life, now and in the future can be increased.

The diagram over sets out the process for installing an on-site wastewater management system.

PTO

Figure 10 Flowchart to design and install an on-site wastewater systems

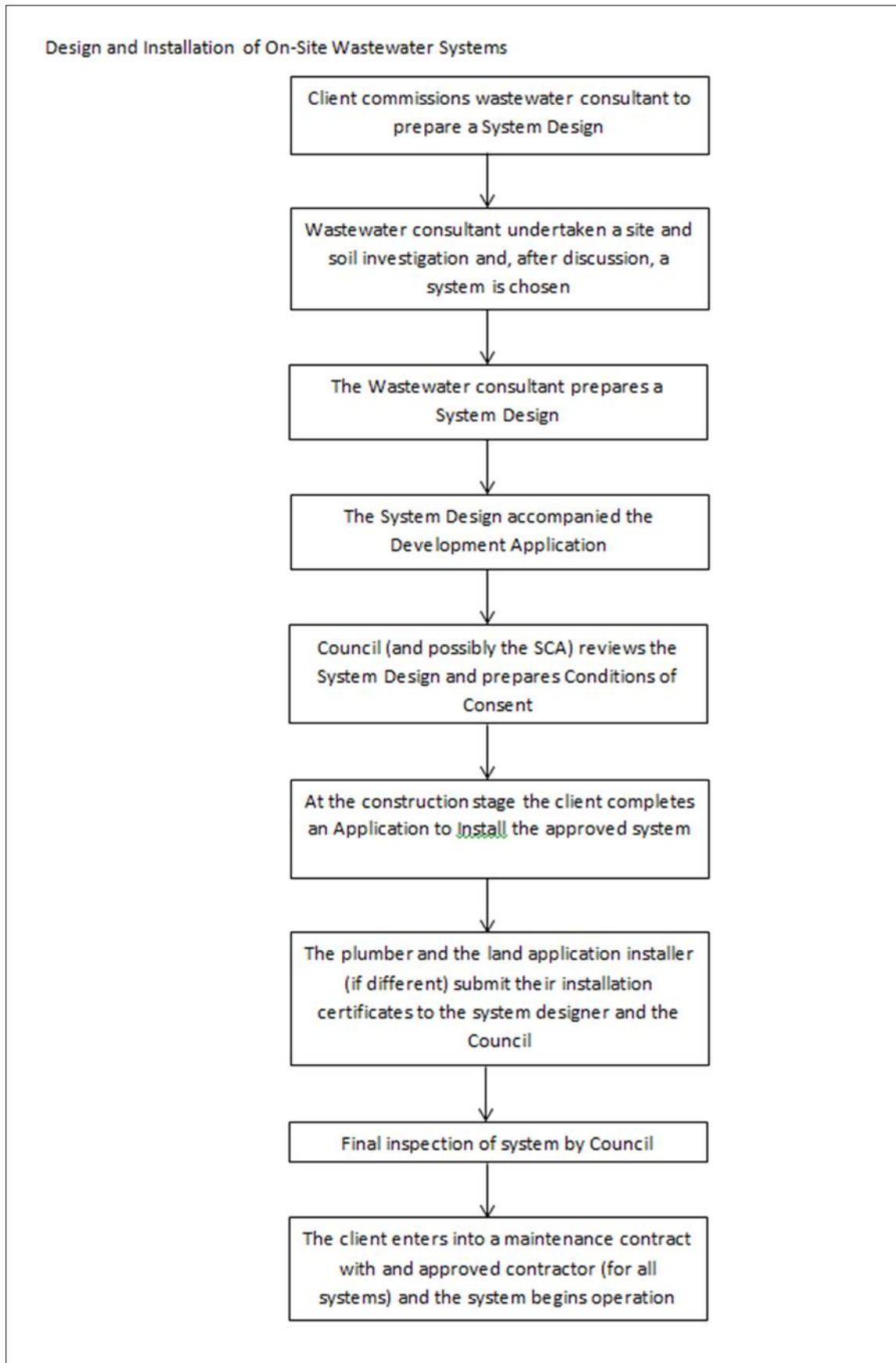

## Guidelines, standards and tools

The guideline *Designing and Installing On-Site Wastewater Systems: A Sydney Catchment Authority Current Recommended Practice* (2014) supplements other existing guidelines and standards for on-site wastewater management, including:

- *AS/NZS 1547* and the *Environment & Health Protection Guidelines: On-site Sewage Management for Single Households* (the *'Silver Book'*) (*Department of Local Government, 1998*) which are both current recommended practice for on-site wastewater management
- the brochure *'Developments in Sydney's Drinking Water Catchment – Water Quality Information Requirements'* (available at [www.sca.nsw.gov.au](http://www.sca.nsw.gov.au)) is a performance standard developed by the SCA.

## Wastewater Site Assessment and System Selection

This choice of system must be made in accordance with the current version of *AS/NZS 1547 On-site Domestic Wastewater Management* and the *Department of Local Government's 'Silver Book'* following a site assessment by a wastewater consultant. This assessment must recommend a particular combination of a treatment system and land application method. This information must be provided in an on-site wastewater report and submitted as part of the development application.

## Development Application Requirements - On-site System of Sewage Management Report

All applications to install and alter an effluent disposal management system must be accompanied by a waste water report that includes the following information:

### 1. Waste Water Loading

For residential dwellings (including dual occupancies) design waste water loading based on the number of potential bedrooms (including rooms capable of being a bedroom) and type of water supply as follows.

Table 9 Wastewater loading

	1-2 bedrooms	3 bedrooms	4 bedrooms	5 or more bedrooms
Tank Water Supply	400L/day	600L/day	800L/day	100L/day extra for each additional bedroom
Reticulated/bore supply	600L/day	900L/day	1200L/day	150L/day extra for each additional bedroom
Source: SCA Guidelines				

**Note:** For non-dwelling proposals the wastewater loading must be in accordance with *AS/NZS 1547:2000 - On-site domestic wastewater management*.

### 2. Site Map

A site map which identifies all surface constraints including:

- The drainage network, water courses, drainage depressions and dams, roadside and other open drains
- Vegetation and shading/exposure
- Orientation
- Any poor drainage/wet seepage areas and springs
- River flats/floodplains or flood planning level
- Any ground water bores located within 100m of the effluent management area and their use

- Existing wastewater management structures and effluent management areas,
- Slope (%)
- General land form
- Areas of runoff
- Rock outcrops and geology
- Stormwater management structures and erosion control measures
- All existing and proposed structures including buildings, accessways or roads, livestock yards
- Buffer distances
- Exposed soil/erosion potential/fill
- Any environmentally sensitive areas of, any land located within 100 metres of the sewage management facility or related effluent application areas
- Any building or facility located within 100m of the proposed effluent management system

### 3. Soil information

Detailed soil information must include soil profiles of up to at least one metre (where possible) taken from the specific location of the proposed effluent management areas consistent with *AS/NZS 1547:2000 On site domestic wastewater management*. This information must describe:

- the soil texture and structure with depth as per *AS/NZS 1547:2000*,
- the dispersibility, and
- other relevant chemical or physical characteristics that could impact on sustainable effluent disposal as identified in the Silver Book or *AS/NZS 1547:2000*.

The information should also consider the following where relevant to the site:

- electrical conductivity/salinity (>8 dS/m is not suitable unless the soil is treated),
- sodicity (>10% is not suitable unless the soil is treated), and
- phosphorous sorption values for permeable sandy or granitic soils where effluent irrigation is proposed.

### 4. Climate Information

Monthly rainfall and evaporation data.

### 5. Existing systems

Where an existing system is to be upgraded or augmented, the location, nature, size/capacity, condition, and disposal area of the existing on site waste system must be clearly specified.

The proposed upgrading or augmentation of the effluent disposal system must be clearly identified, including the extra or expanded areas and the need for higher capacity pumps.

### 6. Proposed systems

The report must include details of the chosen effluent disposal system and must be designed in accordance with:

- *AS/NZS 1547:2000 - Disposal Systems for Effluent from Domestic Premises*, and
- “*Silver Book*” - *Environment and Health Protection Guidelines - On-site Sewage Management for Single Households (1998)*

The following requirements must be met:

- Absorption trenches and beds, and evapotranspiration absorption beds must be sized as in accordance *AS/NZS 1547:2000*. For primary treated effluent, the conservative design loading must be used.
- Sand mounds sizing should be based on JC Converse and EJ Tyler’s *Wisconsin mound soil absorption system: siting design and construction manual (University of Wisconsin-Madison, 2000)*.



- The irrigation area for surface and subsurface effluent irrigation must be the largest area for the design waste water load and site soil characteristics determined by the hydraulic, nitrogen and phosphorous loadings as per *AS/NZS 1547:2000* and the *Silver Book*
- The weighted phosphorus absorption values relevant to the soil profile at the specific site for the effluent irrigation area and not those in the *Silver Book* must be used to determine the size of the effluent irrigation area based on nutrient balance.

## Control

- 1) The full specifications of the On-site Sewage Management Facility proposed to be installed or constructed on the premises concerned must be submitted.
- 2) A site plan must be submitted that shows the location of the proposed effluent management system in relation to:
  - Buffer distances to named rivers and water supply reserves (150m), water courses (100m), drainage depressions and dams (40m)
  - Groundwater bores within 100m and if <100m then the site plan must be accompanied by a statement from the owner of the bore that it is not used for potable domestic water supply
  - Setback distance to property boundaries, buildings and other infrastructure (both existing and proposed) as per Table 5 of the *Silver Book*
- 3) The site plan must show the location of any existing On-site Sewage Management System tanks, piping and effluent management area(s) that will be augmented or decommissioned, or where these systems are located close to a new On-site Sewage Management System
- 4) The application must be accompanied by details of:
  - The operation and maintenance requirements for the proposed On-site Sewage Management System. The On-site Sewage Management System to be installed or constructed must be accredited by the NSW Department of Health.
  - the proposed operation, maintenance and servicing arrangements intended to meet those requirements
  - the action to be taken in the event of a breakdown in, or other interference with its operation.

## Effluent irrigation

- 1) Subsurface irrigation will be required if the:
  - Average annual rainfall exceeds 1200mm,
  - Neighbouring dwellings are within 100m of the proposed effluent management area,
  - Effluent management area slope is greater than 7%,
  - On-site Sewage Management System is to be located within an unsewered residential area.
  - The effluent irrigation area needs to be regularly mowed to maintain a maximum height of 100mm to remove nutrients for long term sustainability.
- 2) Where surface irrigation is proposed, moveable hoses, including semi fixed systems will not be acceptable

## Unacceptable practices

- 1) The following systems will not be acceptable:
  - Trench system longer than 200m
  - Absorption systems where soil is medium or heavy clay
  - Absorption systems where there is less than 0.75m of soil
  - Trenches more than 20m long except where they are made of 2 separate inline trenches with a central feeder or where trenches are pressure dosed from a pump well

- Amended soil mounds with slopes of more than 7%
- Solar powered systems where continuous power is required for normal operation such as aerated wastewater treatment systems
- Reed bed systems except in exceptional circumstances
- Pump out systems for domestic use.

### Installation

All systems should be installed according to NSW Workplace Safety requirements and *AS/NZS 3500 (Set):2003 Plumbing and Drainage Set*.

### Renewal of on-site wastewater approvals

Approvals to operate an OSSM under Section 68 of the *Local Government Act* are only issued for a specified period of time and must be renewed before expiry. To ensure that OSSMs comply with legal requirements, all OSSMs need to have a current approval to operate. After installation, all OSSMs are require to be maintained in accordance with Section 5 of the Silver Book and *AS/NZS 1547:2000*

### Further information

*Fact Sheet: On-Site System of Sewage Management Approvals Function Overview* available on Council's website [www.qprc.nsw.gov.au](http://www.qprc.nsw.gov.au).

**Note:** Greywater reuse will require a separate approval. This is addressed in section B.16 Greywater reuse in this DCP.

## B14 Potentially contaminated land

### Objective

- To ensure that changes of land use will not increase the risk to health or the environment from previous land use
- To provide information to support decision making

### Control

- Any development application for the development of land shall consider the potential for the site to be contaminated from a previous or current land use
- Land identified as being potentially contaminated shall be assessed in accordance with the provisions of *State Environmental Planning Policy (Resilience and Hazards) 2021*

Table 10: Some activities that may cause contamination

Some activities that may cause contamination	
Acid/alkali plant and formulation	Metal treatment
Agricultural/horticultural activities	Mining and extractive industries
Airports	Oil production and storage
Asbestos production and disposal	Paint formulation and manufacture
Chemicals manufacture & formulation	Pesticide manufacture and formulation
Defence works	Power stations
Drum reconditioning works	Railway yards
Dry cleaning establishments	Scrap yards
Electrical manufacturing (transformers)	Service stations
Electroplating and heat treatment premises	Sheep and cattle dips
Engine works	Smelting and refining
Explosive industry	Tanning and associated trades

Gas works	Waste storage and treatment
Iron and steel works	Wood preservation
Landfill sites	

Source: *Remediation of Land and Managing Land Contamination: Planning Guidelines* (EPA 1998)

### Further information

NSW Environmental Protection Authority [www.epa.nsw.gov.au](http://www.epa.nsw.gov.au)

## B15 Waste management

### B15.1 General Controls

#### Objective

- To avoid the generation of waste through design, material selection and building practices
- To encourage waste minimisation, including source separation, reuse and recycling
- To ensure efficient storage and collection of waste and quality design of facilities

#### Control

##### B15.1.1 Waste management plan

- A waste management plan and details of on-site waste management facilities is to be submitted with all development applications for all residential buildings

##### B15.1.2 Demolition of buildings

Refer to C23 Demolition of buildings or structures in this DCP

##### B15.1.3 Removal of asbestos

- Demolition works involving the removal and disposal of asbestos cement must only be undertaken by contractors who hold a current WorkCover “Demolition Licence” and a current WorkCover “Class 2 (Restricted) Asbestos Licence”
- All asbestos laden waste, including asbestos cement, asbestos contaminated soils and flat and corrugated sheets must be disposed of at a landfill facility licensed for receiving asbestos
- On completion of demolition works, the applicant must lodge with Council, all original weighbridge receipts issued by the receiving landfill as evidence of proper disposal

##### B15.1.4 Design of buildings

- Second hand and recycled building materials should be considered for use in building construction
- Building design is to incorporate techniques which minimise waste before, during and after construction
- Residential building design is to encourage residents to separate garbage for recycling, e.g. a waste cupboard which allows the temporary storage of garbage, recyclables and compostable materials

##### B15.1.5 Construction of buildings

- An onsite sorting and storage area for builders’ waste and vehicular access to and on-site is to be detailed on the site plan
- The on-site storage area is sufficiently large to allow separation of materials to encourage diversion of materials from landfill

#### Further information

- [www.nsw.gov.au/fibro-and-asbestos-frequently-asked-questions](http://www.nsw.gov.au/fibro-and-asbestos-frequently-asked-questions)
- [www.workcover.nsw.gov.au](http://www.workcover.nsw.gov.au)

## B15.2 Commercial and Industrial Waste

### Objective

- a) To ensure that waste from commercial and industrial developments is appropriately managed and if possible recycled
- b) To reduce vehicle and pedestrian conflicts in the management of commercial and industrial waste

### Control

#### B15.2.1 Waste management plans for industrial and commercial development

- 1) A waste management plan for waste generated from commercial and industrial business activities is to be submitted with a development application. Plans are to include information on how and where waste will be disposed. Full details of anticipated vehicle sizes, volumes and frequency of delivery and other service vehicles must be provided. These estimates, particularly vehicle sizes, must be realistic and based on established averages for the range of businesses likely to occur in the development

#### B15.2.2 Waste collection

- 1) All business development where future tenants will require regular deliveries of goods and the removal of waste and resource recovery material must ensure that loading facilities are adequate for the realistic needs of the proposed service vehicles
- 2) AUSTRROADS Design Vehicles and Turning Templates must be used for all vehicle movements on, or on to, public roads
- 3) The turning templates from Australian Standard *AS 2890.1* and *AS 2890.2* must be used for on-site manoeuvring, including reversing manoeuvres and vertical clearance requirements
- 4) For retail developments with a gross leasable floor area of less than 1,000 square metres and not a supermarket, discount department store or other high volume delivery usages, the following is required:
  - a) Either a loading facility onsite to accommodate a Heavy Rigid Vehicle (12.5 metre) as defined by *Australian Standard AS 2890.2*, or Single Unit Truck (12.5 metre) as defined by Austroads 2008 as the minimum standard, may be permitted to utilise a loading zone if it is within 50 metres as measured along the travel path
  - b) Consideration of servicing of the development by vehicles equal to or larger than a Medium Rigid Vehicle (8.8 metre) as defined by *Australian Standard AS 2890.2*, or Service Vehicle (8.8 metre) as defined by Austroads 2008, may be deemed as the appropriate design vehicle, subject to the provision of supporting evidence
  - c) No use of the loading zone will be permitted where deliveries require the use of fork lifts, or other mechanically assisted lifting devices on the footpath or crossing a public road or footpath
  - d) Council will require a positive covenant to be placed on the title of the land giving Council the power to release, vary or modify the restriction to enforce the requirements of this clause
- 5) For retail developments with a gross leasable floor area of 1,000 square metres or greater or developments such as supermarkets, discount department stores or other high volumes delivery usages, the following controls shall apply:
  - a) The development shall provide a loading facility to accommodate an Articulated Rigid Vehicle (19.0 metre) as defined by *Australian Standard AS 2890.2* or Single Articulated Vehicle (19.0 metre) as defined by Austroads 2008 as the minimum standard
  - b) Council will require a positive covenant to be placed on the title of the land giving Council the power to release, vary or modify the restriction to enforce the requirements of this clause

- c) The reversing of vehicles on to a main road, or arterial road, or future by-pass route, or any other public road, will not be permitted
- d) The design of off-street commercial vehicle facilities must comply with *AS 2890.2: 2002*
- e) Loading bays are not to be used for the storage of goods or waste storage other than during the unloading / loading process
- f) Waste and resource recovery material storage should be enclosed or screened from the road in a dedicated facility
- g) Waste and resource recovery material collection shall be from the loading facility if one is provided with the development. If no loading facility is provided then the collection of waste and resource recovery material must be from a central collection area by private contractor. The waste and resource recovery material must be collected outside of business hours to ensure disruption to the public is minimized

## B16 Greywater reuse

*Grey water* is waste water which does not arise from a toilet and may include waste water from a hand basin, shower, laundry and kitchen.

*Black water* is waste water generated from a toilet, bidette or bidet which is heavily and directly contaminated with human faeces or urine and may contain contaminated solid material such as toilet paper. This wastewater is highly infectious.

Grey water is often contaminated with human faeces, dirt and other materials but to a lesser extent than black water and is therefore less infectious than black water.

Reusing grey water can replace the need to use potable (drinking) water for watering gardens or lawns and, if treated appropriately, can be used in toilets and washing machines. By using grey water for watering gardens and lawns, a household has the potential to save between 50,000 and 100,000 litres of potable water a year.

Grey water use systems have been listed under the **BASIX** program as one of the most effective ways to reduce the use of potable water supplies in residential developments.

Grey water treatment systems are different to Aerated Wastewater Treatment Systems (AWTS) which are often used to dispose of sewage on rural properties.

Grey water contains micro-organisms, chemical contaminants (in particular nutrients such as nitrogen and phosphorus, salts and physical containments (such as dirt, lint and sand). Care should be taken when handling and disposing of grey water. Untreated grey water should not be used for the following purposes:

- drinking, cooking or any kitchen purposes
- swimming pools
- baths, showers, hand basins or any personal washing
- water contact recreation e.g. playing under sprinklers
- irrigation of crops for human consumption without processing or cooking

Approval under Section 68 of the *NSW Local Government Act 1993* is required for grey water treatment systems except if the work relates to a single detached dwelling in areas with a reticulated sewage system and the conditions of Section 75A of the *NSW Local Government (General) Regulation 2005* are met.

### Minimum information to accompany the development application

- i. a soil and permeability analysis of the site including whether the site can accommodate the proposed re-use system flows by a qualified and experienced person
- ii. a detailed hydraulic diagram showing:
- iii. the location and design of pipework and disposal area and trenches
- iv. location and design of other fittings such as filters and valves

- v. connection to overflow sewer
- vi. methods for automatically switching off the subsurface disposal device when the disposal area has become saturated
- vii. an assessment of the capacity of the diversion area to receive recycled water (identifying a maximum daily diversion flow)
- viii. the measures to ensure that all pipes and fittings and the diversion area are adequately identified as being used for wastewater reuse
- ix. the maintenance regime to ensure that the device is in good working order
- x. in the case of multi dwelling housing, residential flat buildings and commercial premises, a management plan detailing:
  - the treatment process
  - routine sampling program
  - maintenance emergency contact numbers
  - system failure procedures
  - auditing procedures to detect cross-connections and contingency plans for the management for wastewater and water requirements in the event of system failure

### Guidelines

*NSW Guidelines for Greywater Reuse in Sewered, Single Household Residential Premises*

A list of accredited systems is available at NSW Health at

<http://www.health.nsw.gov.au/PublicHealth/environment/water/wastewater.asp>

### Objective

- a) To encourage the reuse of grey water so that water savings may occur
- b) To ensure that grey water is managed in a safe manner

### Control

- 1) Grey water disposal will not be permitted within 50 metres of a watercourse or within a flood planning area
- 2) A licensed plumber is required to install the device

## B17 Rainwater tanks

Rainwater tanks provide benefits by reducing mains water demand and stormwater flow from properties.

The installation of a rainwater tank may be exempt development. Refer to the *State Environmental Planning Policy (Exempt and Complying Development Codes) 2008*. If it is not exempt a development application will be required.

### Objective

- a) To reduce the demand on reticulated water services and stormwater flow from properties

### Control

- 1) Rainwater tanks of the minimum sizes indicated in the table below must be installed with each new dwelling where a reticulated town water supply is available

Table 11 Minimum rainwater tank sizes

Number of Bedrooms	Minimum Tank Size
3 or more	22.5 Kl
2	13 Kl
1	9 Kl

- 2) Residential developments that rely solely on tank water will need larger tanks to achieve security of supply than those that are supplemented by a mains water top up system
- 3) The size of rainwater tanks may need to be larger if they are also being utilised to satisfy conditions of development to achieve on site detention of stormwater. Refer to section B7.7 Stormwater in this DCP
- 4) Figure 9 below shows how Council requires rainwater tanks to be installed with plumbing arrangements that:
  - provides a mains water supply top up system. The bottom 20% of the tank comprises the mains water top up zone with up to 80% of the storage being available for rainwater capture
  - ensure the tank supplies water for outside irrigation, toilet flushing and laundry (and hot water and other uses at the owner's discretion following assessment of risk) in accordance with BASIX
  - includes the provision of an anaerobic zone below the pump draw-off level, a gap at the top above the overflow to prevent backflow (in accordance with AS.3500.1 and 2 (1998)) and a first flush device on the inlet from the roof to dump the first flow washing off the roof

Figure 11 An example of a typical rainwater tank installation with mains utilised for certain household uses and for topping up the tank

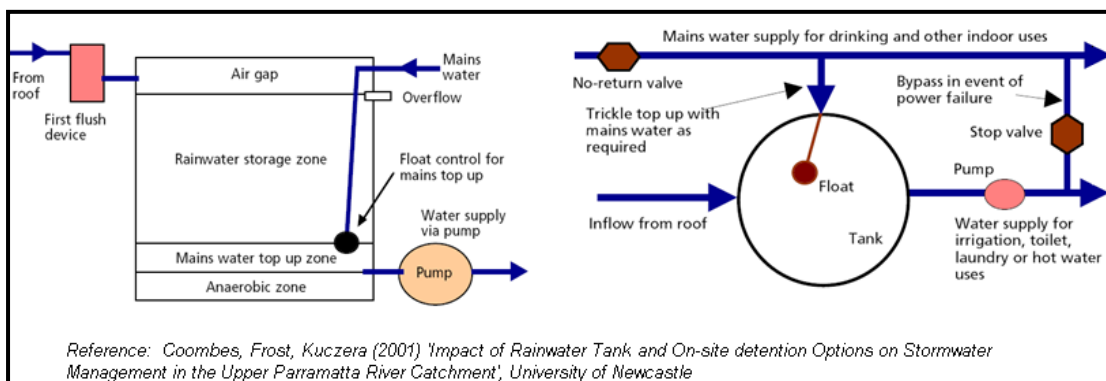

- 5) The current version of HB230 Rainwater Tank Design and Installation Handbook shall be adhered to when installing rainwater tanks
- 6) Tanks are to be located behind the front building alignment (and side building alignment for corner blocks) and are to be at least 900mm from the side and rear boundaries
- 7) Rainwater tanks must be prefabricated, or constructed of prefabricated elements that were designed and manufactured for the purpose of construction of a rainwater tank and the tank must be assembled and installed in accordance with the HB230 Rainwater Tank Design and Installation Handbook
- 8) Rainwater is to be sourced from roof surfaces only, and shall not be sourced from roofs coated with lead or bitumen - based paints, or from asbestos-cement roofs

- 9) In the case of large scale developments rainwater tank sizing shall be determined by a comprehensive water cycle strategy to meet water demand reduction targets in accordance with BASIX
- 10) Where tank water is to be used for human consumption, it is recommended that the property owner consult the Rainwater Tanks brochure produced by NSW Health and the publication titled *Guidance on the use of rainwater tanks Water Series No. 3 1998*, published by the National Environmental Health Forum, available on [www.hprb.health.nsw.gov.au](http://www.hprb.health.nsw.gov.au)
- 11) The rainwater tank and all fixtures connected to the rainwater supply system are to be marked 'RAINWATER'
- 12) The tank is to be enclosed and inlets screened so as to prevent the entry of foreign matter and to prevent mosquito breeding
- 13) Tank overflows must connect to an approved disposal system, either to a retention/infiltration device, swale, stormwater drain or street gutter and must not cause nuisance to neighbouring properties
- 14) Pumps are to be covered or screened to avoid noise nuisance to neighbouring properties
- 15) The tank is to be maintained by the property owner to ensure adequate functioning and compliance with accepted health requirements
- 16) Rainwater tanks are to be connected to the roof so as to maximise roof water capture
- 17) Tank colours must be compatible with the dwelling
- 18) Rainwater tanks shall not be located over sewer mains or other easements
- 19) All new dwellings in rural areas where no Council reticulated water supply system exists are to be supplied with 90,000 litre water tanks in addition to tanks required under the documents *Planning for Bushfire Protection 2019*

## B18 Solid fuel heaters

### Objective

- a) To ensure that solid fuel heaters are safe and efficient

### Control

- 1) Under section 68 of the *Local Government Act 1993* all solid fuel heater installations and replacements, including new and second hand heaters and heaters that are being relocated require approval from Council. The installation must comply with the *Building Code of Australia* and *Australian Standard 2918 (Domestic solid fuel burning appliances—Installation)*. Gas or oil fired appliances do not require specific Council approval. However, a compliance plate and associated certification must be provided to property owners, by a licensed installer. Existing heaters or second hand units and associated flue installations are to be accompanied by the same information as new heaters. Where no manufacturers' specifications are available council will only approve installations which comply with the *Building Code of Australia*
- 2) Applications must include the following:
  - floor plan for the location of the solid fuel heater
  - manufacturers details showing appropriate setback to combustible materials
  - Details of the licenced installer. Installers must have the appropriate licence from New South Wales Fair Trading (either a builders licence, a roof plumbing licence or a minor works licence). Work cannot start until approval is obtained.
- 3) A certificate from the installer is required for flue installations prior to Council certifying the completed works
- 4) Selection of the solid fuel heater and subsequent use is to comply with the emission recommendations of the NSW Environmental Protection Authority

**Note:** Solid fuel heaters are to be included in the BASIX assessment if the heater will be the primary source of heating



### Further information

NSW Department of Planning and Environment

## B19 Sydney, Googong and Captains Flat drinking water catchments

The local government area contains three drinking water catchments. These are catchments where surface water for the urban areas of Captains Flat, Queanbeyan, Canberra and Sydney are collected. Through controlling development in these catchments, there is less likelihood of there being poor quality drinking water for these urban areas. Not only is poor quality drinking water unsatisfactory for health reasons, it is expensive to manage such water. The *QPRLEP2022* Drinking Water Catchment Map shows the three drinking water catchments and clause 7.3 of the *QPRLEP2022* sets out the requirements in regard to land use and the catchments.

Additionally, the NSW *Protection of the Environment Operations Act 1997* controls matters such as pollution. *The State Environmental Planning Policy (Biodiversity and Conservation) 2021* controls development and activities in the Sydney drinking water catchment.

### Further information

Water NSW website at [www.water.nsw.gov.au](http://www.water.nsw.gov.au)

Council has applied the Water NSW approach to the assessment and management of waste water across the entire Palerang local government area. For further information refer to section B13 On-site System of Sewage Management (OSSM) in this DCP.

# Part C Development Specific Provisions

## C1 Subdivision

The *QPRLEP2022* provides the opportunity for the subdivision of land for residential, industrial or commercial purposes or primary production depending on the land use zone. In some instances subdivision may be possible as 'exempt' development under the *State Environmental Planning Policy (Exempt and Complying Development Codes) 2008*.

This section has been divided in to three parts:

- 1) subdivision for primary production in the RU1 Primary Production use zones
- 2) subdivision for purposes other than primary production – general controls
- 3) specific requirements for the following land use zones:
  - RU1 Primary Production
  - C3 Environmental Management and C4 Environmental Living
  - RU5 Village
  - R5 Large Lot Residential
  - R1 General Residential and R2 Low Density Residential
  - B2 Local Centre and B4 Mixed Use
  - IN2 Light Industrial

### C1.1 Subdivision for primary production in RU1 Primary Production

Part 4 of the *QPRLEP2022* provides the provisions for subdivision for primary production in RU1 Primary Production and other land use zones.

#### Minimum information to accompany a development application

- the information required in section B1 of this DCP
- the purpose of the subdivision
- the proposed access to lots

#### Objective

- a) To ensure that all lots have suitable access

#### Control

- 1) Refer to section B7 engineering requirements in this DCP

### C1.2 Subdivision for purposes other than primary production – general controls

The following controls apply to all subdivisions for purposes other than primary production.

#### Minimum information to accompany a development application

- the information required in section B1 of this DCP
- information required in this and other sections of this DCP
- MUSIC Modelling for subdivisions which propose more than four lots

## C1.2.1 Site analysis

- 1) The subdivision design is to be responsive to the natural environment with the following factors to be given consideration:
  - climate
  - landform
  - aspect and views
  - geology and soils
  - drainage
  - vegetation and biodiversity
  - bush fire prone land
  - surface and groundwater

The site attributes and constraints are to be included in the site analysis report and maps.

- 2) Prior to the lodgement of the development application, the proposed lots shall be marked at each corner by one metre high stakes and the corners of the proposed building envelopes shall be identified by one metre high stakes with suitable highly visible tape.

## C1.2.2 Lot orientation

Well orientated lots within a subdivision enable buildings to be sited so that they can include passive solar design features and allow a greater area of roof space to be positioned for solar energy purposes.

### Objective

- a) To ensure that lot orientation maximises energy efficiency and conservation principles

### Control

- 1) Lot size, shape and orientation is to provide optimal opportunity for passive solar design of future buildings
- 2) Lots are to be oriented north/south in urban areas. Building envelopes on larger lots or in rural areas are to be of sufficient size and orientation to allow construction of a building with a north/south orientation
- 3) New roads are to be aligned east-west and north-south wherever possible, with north-south streets within 20° west and 30° east of true north and east-west streets within 30° south and 20° north of true east
- 4) Lots with an east-west orientation may require, depending on lot size, to be widened to provide for optimal solar access and to prevent overshadowing of buildings and private open space on adjoining lots
- 5) Design of lots on sloping sites will be required to:
  - minimise the need for boundary retaining walls
  - minimise the potential for overlooking of adjoining properties and
  - maintain solar access.
- 6) Smaller lots are to be located on north facing slopes and larger lots are to be located on south facing slopes as shown in the diagrams below.

Figure 12 Lot orientation

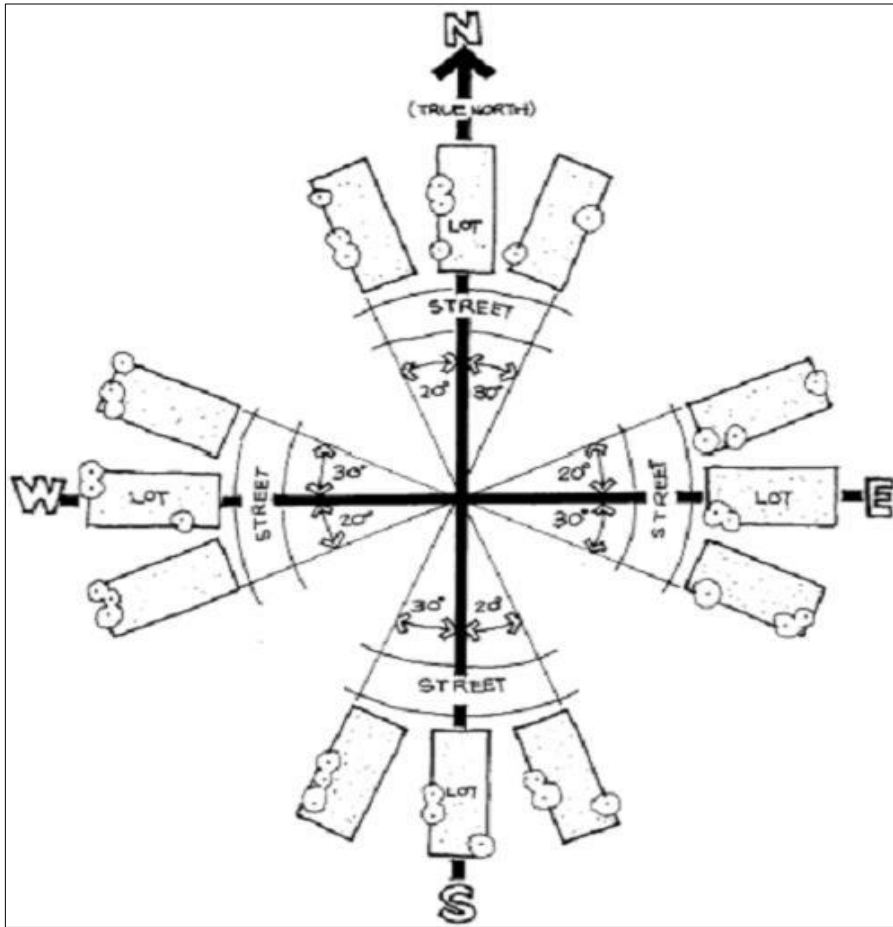
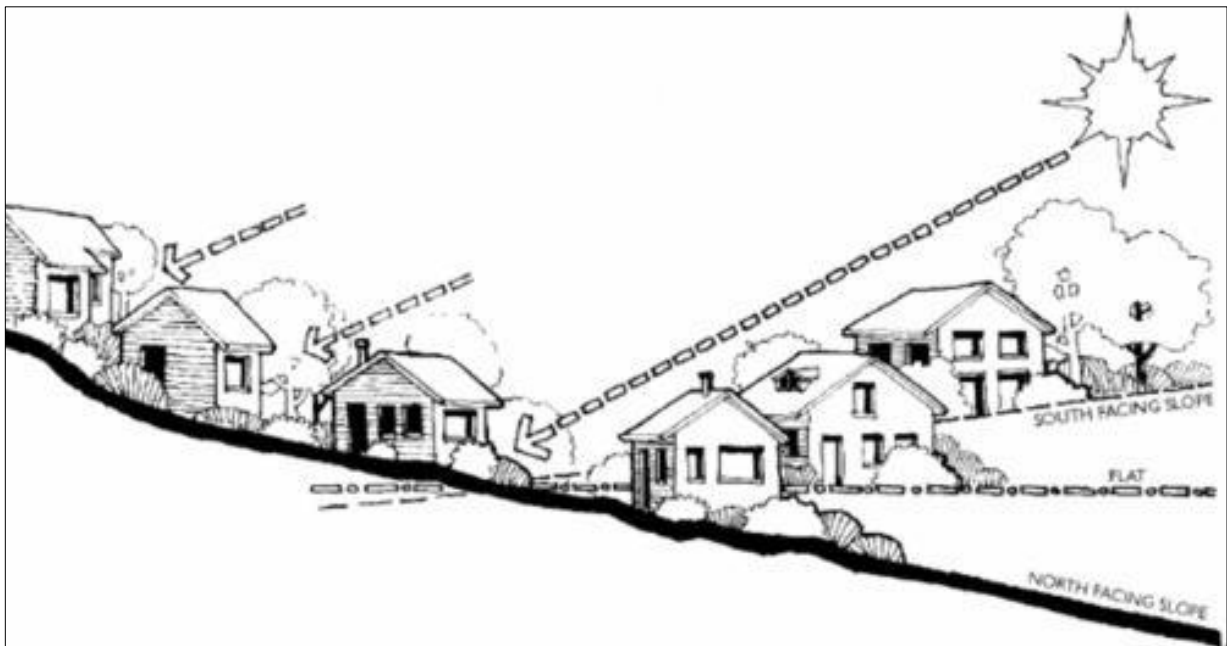

Figure 13 Cross section lot orientation



Source: AMCORD 1995

## C1.2.3 Subdivision pattern

### Objective

- a) To ensure the appearance and layout of new subdivisions are sympathetic to the character of existing residential areas

### Control

- 1) New lot boundaries within the village area of Bungendore and Braidwood shall be parallel to or at right angles to the historic subdivision grid
- 2) Subdivision is not to result in built forms that will have detrimental impact on the traditional patterns and rhythms of the streetscape
- 3) Subdivision shall not result in the creation of stacked battleaxes or adjacent groups of battleaxe driveways
- 4) Lots are to be designed that allow for buildings to be erected on the primary street frontage (battle axe block and rear laneways excepted)
- 5) Smaller lots should utilise flat treeless sites as this reduces the likelihood of cut and fill and vegetation removal
- 6) In land use zones C4, C3 and RU1, where land fronts a watercourse shown on the *QPRLEP2022 Riparian Lands and Watercourse map*, the lots will have a frontage to that watercourse of not less than 200 metres. Where lots have an existing frontage to a watercourse less than 200 metres, the existing frontage is to be retained
- 7) The depth of the lot shall not exceed the width of the lot by more than 4:1

## C1.2.4 Road networks and design

### Objective

- a) To provide a hierarchical network of roads with clear distinctions between each type of road based on function, capacity, vehicle speeds and safety
- b) To ensure that the road design fits within the existing hierarchy of roads
- c) To provide appropriate access for service and emergency service vehicles
- d) To allow for public utilities, services and drainage systems to be coordinated without impacting adversely on road pavements
- e) To ensure that the street network provides convenient, connected and safe access for pedestrians (especially children), cyclists, horse riders and vehicles
- f) To create a permeable and legible street hierarchy that responds to the natural site topography and native vegetation

### Control

- 1) Refer to Section B7 Engineering in this DCP
- 2) All development applications must include a road layout plan (including road type) that meets the requirements of this DCP
- 3) New corner lots created by subdivision shall use splay corners where necessary to maintain sight distances

## C1.2.5 Building envelopes

### Objective

- a) To ensure that buildings will be located in an area that has the least impact on the natural environment, amenity and views and vistas

### Control

- 1) Building envelopes are to be placed on all lots in the following land use zones:

- RU1 Primary Production
  - C3 Environmental Management
  - C4 Environmental Living
  - R5 Large Lot Residential
- 2) The location of building envelopes on lots shall reflect the findings of the site analysis and be free of major environmental and servicing constraints
  - 3) Building envelopes are to be designed based on the constraints associated with effluent disposal, heritage, ecological items, utilities or easements and the natural features of the land
  - 4) The proposed building envelope within which a house, ancillary buildings (other than animal shelters with a gross floor area of not more than 25m<sup>2</sup>), water tank and the like could be located is to be marked on the plan and shall:
    - be a minimum size of 2000m<sup>2</sup> or 4000m<sup>2</sup> where there is not a reticulated sewerage system
    - have a slope not greater than 15 per cent
    - be setback a minimum distance indicated in Table 12:

Table 12 Setbacks for building envelopes

Setbacks for building envelopes	RU1 Primary Production	C3 Environmental Management and C4 Environmental Living	R5 Large Lot Residential
Front boundary (metres)	50	50	7
Side and rear boundaries (metres)	15	15	15
<4ha			
4ha- 80 ha	25	25	25
> 80 ha	50	50	50

## C1.2.6 Potable water

### Objective

- a) To provide a regular supply of potable water, with sufficient capacity for peak usage, fire fighting and long-term development
- b) To provide an adequate supply of potable water for sites that cannot be connected to the water supply
- c) To provide an adequate supply of water for bush fire protection

### Control

- 1) A reticulated water supply is to be provided for all subdivisions where an existing reticulated water supply is provided nearby. Generally, this shall include all subdivisions in Braidwood, Captains Flat and Bungendore. Refer to section B7 Engineering requirements in this DCP

## C1.2.7 Sewerage

### Objective

- a) To ensure that residential areas are serviced with a sewage management system that is cost effective and efficient and supports sustainable practices
- b) To ensure that where on-site sewage management systems are required it does not result in:
  - land quality deterioration through chemical or biological contamination or degradation of soil structure
  - contamination of surface waters, subsurface flow or groundwater

## Control

- 1) Where a reticulated sewage system is available nearby, all lots shall be connected to the reticulated sewerage system. Refer to section B7 Engineering requirements of this DCP. Generally, this shall include all subdivisions in Braidwood, Captains Flat and Bungendore
- 2) Where there is no reticulated sewerage system, an on-site system of sewage management (OSSM) report is to be provided. The proposed effluent disposal envelope is to be included within the building envelope (with an area of 4,000m<sup>2</sup>) on the plan and will be placed on the certificate of title under a section 88B instrument. Refer to section B13 – On-site sewage management systems (OSSMs) in this DCP and section C1.2.5 Building envelopes

## C1.2.8 Stormwater drainage

### Objective

- a) To control and manage all stormwater generated within the development
- b) To control and manage all stormwater passing through development from the surrounding catchments
- c) To provide a legal point of discharge for all collected stormwater water to a natural water course or council drainage system
- d) To not have an adverse impact on the environment, surface and subsurface water quality and adjoining land either upstream or downstream of the subdivision
- e) To protect and enhance the natural water courses, aquatic habitat and riparian vegetation

### Control

- 1) The development application is to be accompanied by a Storm Water Management Plan prepared by a certified practicing engineer and in accordance with the requirements of section B7 Engineering requirements in this DCP

## C1.2.9 Electricity

### Objective

- a) To provide logical, efficient and environmentally sensitive extensions to electricity supply networks
- b) To promote opportunities for on-site generation of power

### Control

- 1) Suitable power shall be provided by the developer to the boundary of all additional lots created in accordance with the requirements of the electricity supply body
- 2) Written evidence from the electricity supply body that the electricity infrastructure is satisfactory will be required prior to release of subdivision certificate
- 3) Consideration will be given to renewable energy sources in lieu of connection to the network in land use zones RU1 Primary Production, C3 Environmental Management and C4 Environmental Living.
- 4) Refer to section B7 Engineering requirements in this DCP

## C1.2.10 Telecommunications

### Objective

- a) To ensure that proposed lots can be serviced by telecommunications infrastructure

### Control

- 1) Refer to section B7 Engineering requirements in this DCP

## C1.2.11 Service easements

### Objective

- a) To ensure approved development and maintenance can be undertaken

### Control

- 1) Refer to section B7 Engineering requirements in this DCP

## C1.2.12 Natural resources and heritage

### Objective

- a) To ensure that the subdivision of land provides for the protection and management of natural resources, heritage and landscape character

### Control

- 1) The subdivision design should retain existing native vegetation and mature trees. Refer to section B3 Flora, fauna, soil and watercourses in this DCP
- 2) The subdivision design is to retain existing significant heritage. Refer to section B10 Heritage – European (non-Indigenous), Aboriginal (Indigenous) and Natural in this DCP
- 3) Applicants should consult with Council concerning any proposed additions to the Greenway network. Proposed extensions to the Greenway network will require the following:
  - a direct link to a Council owned Greenway
  - that the land to be dedicated to Council at no cost to Council
  - that the land is be free of noxious and environmental weeds prior to acceptance by Council
  - erosion areas should be fenced and ‘active’ areas have been treated
- 4) Crown Public roads that are not being purchased for an addition to the Greenways network or for other community purposes are to be closed and consolidated within the lots being created. This control should be discussed with Council at the commencement of the design of the subdivision

## C1.2.13 Views and vistas

### Objective

- a) To ensure that all dwellings have a view that reflects the rural character of the locality whilst not having a negative impact on significant views and vistas

### Control

- 1) The subdivision should be designed to minimise the impact on significant views and vistas. Refer to section B6 Visual impact of development in rural and environmental land use zones and for urban areas section D Area specific provisions of this DCP

## C1.2.14 Soil management

### Objective

- a) To minimise erosion and sediment loss before, during and after construction
- b) To minimise water pollution due to sedimentation
- c) To minimise the requirement for and impact of fill

### Control

- 1) An Erosion and Sediment Control Plan or Soil and Water Management Plan (depending on scale of the proposed development) is to be submitted with the development application. Refer to section B8 – Erosion and sediment control in this DCP



- 2) The building envelopes are to be sited so as to minimise the requirement for cut and fill

## C1.2.15 Public open space

### Objective

- a) To provide access to active and passive open space to meet the needs of the local population where the subdivision involves a large number of residential lots

### Control

- 1) Parks and open space areas should be integral to neighbourhood design and should respond to the opportunities and constraints in providing a range of recreational and environmental settings and corridors
- 2) Design and locate open space and recreation areas to maximise connections and to adjoining land uses and local roads
- 3) Ensure that public open space areas are suitable for the required use and locate open space and recreation areas to maximise connections to adjoining land uses and local roads and pedestrian/cycle networks
- 4) Open space areas are to have frontage to at least one road
- 5) The scale of the development will determine whether Council will require development contributions for open space and recreation to be provided in part or wholly through the provision of open space (works in kind) or through the payment of monies. Refer to section A13 Developer contributions in this DCP

## C1.3 Specific requirements for land use zones

### C1.3.1 RU1 Primary Production

#### Objective

- a) To retain the function and character of the existing rural areas
- b) To encourage the retention of higher agricultural potential land
- c) To ensure the subdivision of lots for agricultural purpose results in lots of sufficient size
- d) To ensure that subdivision of the land responds to the topographical and site constraints
- e) To ensure lots have appropriate areas and dimensions for the siting and construction (where permitted) of dwellings and any other ancillary structures on the lot

#### Control

- 1) Subdivision design is to maintain the rural character of the locality
- 2) Subdivisions that are subject to Clause 4.1D of the *QPRLEP2022* must maintain a lot average size identified on the Lot Averaging Map. Each lot created by the subdivision will have an area of at least 8 hectares and no more than 5 lots shall be created less than the minimum lot size shown on the Lot Size Map
- 3) Subdivision design should not result in fragmentation of agricultural or environmental areas
- 4) The size of the lots should be derived from an overall property plan
- 5) Residential lots are to be located on the land with lower agricultural potential where this does not conflict with the need to protect important areas of native vegetation
- 6) Each proposed lot (other than a battle axe lot) that has frontage to a state or regional road is to have a frontage to that road of not less than 200 metres and one entry point for vehicles
- 7) Battle axe lots should be kept to a minimum, but when incorporated within a subdivision the following restrictions shall apply:
  - maximum length of access corridor shall be 300 metres when located to the rear of the lot with an area of less than 20 hectares fronting a road

- minimum width of access corridor shall be 15 metres, or 20m if the lot size allows for further subdivision
  - access handle entrance located to achieve safe and compliant sight distance and in accordance with B7 Engineering within this DCP
- 8) Refer to section C30 Gates and Fencing in this DCP

## C1.3.2 E3 Environmental Management

### Objective

- a) To protect the ecological, scientific, cultural and aesthetic values of the land
- b) To retain the character of the existing landscape
- c) To ensure that subdivision of the land responds to the topography and site constraints
- d) To ensure lots have appropriate areas and dimensions for the siting and construction (where permitted) of dwellings and any other ancillary structures on the lot

### Control

- 1) Subdivisions that are subject to Clause 4.1D of the *QPRLEP2022* must maintain a lot average size identified on the Lot Averaging Map. Each lot created by the subdivision will have an area of at least 8 hectares and no more than 5 lots shall be created less than the minimum lot size shown on the Lot Size Map.
- 2) Subdivision design is to respond to the findings of the site analysis and be free of major environmental and servicing constraints
- 3) Subdivision design shall not result in the fragmentation of environmental areas
- 4) Subdivision design is to reflect existing fence lines or natural features where appropriate
- 5) Dwelling house lots should be located on the land with lower agricultural potential where this does not conflict with the need to protect important areas of native vegetation
- 6) Each proposed lot that has frontage to a main or arterial road must have a frontage to that road of not less than 200 metres and one entry point for vehicles
- 7) Battle axe lots should be kept to a minimum, but when incorporated within a subdivision the following restrictions shall apply:
  - maximum length of access corridor shall be 300 metres when located to the rear of a lot with an area less than 20 hectares fronting a road
  - minimum width of access corridor shall be 15 metres, or 20m if the lot size allows for further subdivision
  - access handle entrance located to achieve safe and compliant sight distance and in accordance with B7 Engineering within this DCP

## C1.3.3 C4 Environmental Living

### Objective

- a) To ensure residential subdivisions have a minimal impact on the ecological, scientific, cultural and aesthetic values of the land
- b) To retain the character of the existing landscape
- c) To ensure that subdivision of the land responds to the topography and site constraints
- d) To ensure lots have appropriate areas and dimensions for the siting and construction of dwellings and any other ancillary structures on the lot

### Control

- 1) Subdivisions that are subject to Clause 4.1E of *QPRLEP2022* in Zone C4 must maintain a lot average size identified on the Lot Averaging Map. Each lot created by the subdivision will have an area of at least 2 hectares. A lot created in accordance with Clause 4.1E cannot be further subdivided.

- 2) Subdivision design is to respond to the findings of the site analysis and be free of major environmental and servicing constraints
- 3) Subdivision design shall not result in the fragmentation of environmental areas
- 4) Subdivision design is to reflect existing fence lines or natural features where appropriate
- 5) Dwelling house lots should be located on the land with lower agricultural potential where this does not conflict with the need to protect important areas of native vegetation
- 6) Each proposed lot that has frontage to a main or arterial road must have a frontage to that road of not less than 200 metres and one entry point for vehicles
- 7) Battle axe lots should be kept to a minimum, but when incorporated within a subdivision the following restrictions shall apply:
  - • maximum length of access corridor shall be 250 metres
  - • minimum width of access corridor shall be 15 metres, or 20m if the lot size allows for further subdivision
  - • access handle entrance located to achieve safe intersection sight distance

### C1.3.4 RU5 Village

#### Objective

- a) To provide a range of lot sizes compatible with the function of a rural village
- b) To retain the character and visual amenity of the village
- c) To ensure lots have appropriate areas and dimensions for the siting and construction of dwellings and other buildings

#### Control

- 1) The subdivision design is to be consistent with the existing subdivision pattern within the locality
- 2) A proposed building envelope is to be marked on the plan within which a house, ancillary buildings, water tank are to be located. The envelope is:
  - to have the following setbacks:
    - 7 metres for the front
    - 0.9 metres for the side and rear
  - have a slope not greater than 15 per cent
  - be sited taking into account the constraints identified in the site analysis and any other relevant report
- 3) A proposed building envelope of 2,000m<sup>2</sup> is to be marked on the plan. In areas that are not connected to reticulated sewer, envelopes are to include a proposed effluent disposal area in accordance with section B13 On-site system of sewage management (OSSM) in this DCP
- 4) Battle axe lots should be kept to a minimum, but when incorporated within a subdivision the following restrictions shall apply to ensure that adequate provision is made for two way vehicular access for future development:
  - The access handle for each lot must have direct frontage to a public road
  - The access handle must have a minimum width of 4.0m and be no longer than 100m
  - A maximum of two lots only will be allowed to be accessed from one access handle

### C1.3.5 R5 Large Lot Residential

#### Objective

- a) To provide for a range of lot sizes for residential housing in a rural setting
- b) To retain the character and visual amenity of the landscape
- c) To promote ecologically sustainable development
- d) To ensure that subdivision of the land responds to the topography and site constraints

- e) To ensure lots have appropriate areas and dimensions for the siting and construction of dwellings and other structures

### Control

- 1) The location of a building envelope on lots shall reflect the findings of the site analysis and be free of major environmental and servicing constraints
- 2) A proposed building envelope is to be marked on the plan within which a house, ancillary buildings, water tank are to be located. The envelope is:
  - to have the following setbacks:
    - 7 metres for the front
    - 15 metres for the side and rear
  - be a minimum size of 1000m<sup>2</sup>
  - have a slope not greater than 15 per cent
  - be sited taking into account the constraints identified in the site analysis and any other relevant report
- 3) On unsewered lots a proposed effluent disposal area envelope of 2,000m<sup>2</sup> is to be marked on the plan. Refer to section B13 On-site system of sewage management (OSSM) in this DCP
- 4) Battle axe lots should be kept to a minimum, but when incorporated within a subdivision the following restrictions shall apply to ensure that adequate provision is made for two way vehicular access for future development:
  - the access handle for each lot must have direct frontage to a public road
  - the access handle must have a minimum width of 4.0m and be no longer than 100m
  - a maximum of two lots only will be allowed to be accessed from one access handle
  - subdivision should reflect existing fence lines or natural features where appropriate

## C1.3.6 R1 General Residential and R2 Low Density Residential

### Objective

- a) To provide for a range of lot sizes for residential housing in a town setting to meet the needs of the future population
- b) To retain the character and visual amenity of Bungendore and Braidwood
- c) To ensure lots have appropriate areas and dimensions for the siting and construction of dwellings and other structures
- d) To ensure the subdivision design is consistent with and respects the existing subdivision and settlement pattern

### Control

- 1) The subdivision design is to be consistent with the existing subdivision pattern in the locality
- 2) Battle axe lots shall be kept to a minimum, but when incorporated within a subdivision the following restrictions shall apply to ensure that adequate provision is made for two way vehicular access for future development:
  - The access handle for each lot must have direct frontage to a public road
  - The access handle must have a minimum width of 4.0m and be no longer than 100m
  - A maximum of two lots only will be allowed from one access handle
- 3) The lot is to have a minimum street frontage of 20 metres unless it is a battle axe lot

## C1.3.7 B2 Local Centre and B4 Mixed Use

### Objective

- a) To provide for the orderly economic development of the centre of Bungendore
- b) To maintain and enhance the character, heritage and amenity of the town centre

- c) To ensure that lots are capable of accommodating the existing or proposed use, including any likely expansion
- d) To ensure the subdivision design is consistent with and respects the existing subdivision and settlement pattern

### Control

- 1) The subdivision design is to reflect the findings of the site analysis and be free of major environmental and servicing constraints
- 2) The subdivision design is to be consistent with the existing subdivision pattern
- 3) Lots are to front constructed roads
- 4) Subdivision development applications should include details of proposed development, including a built form concept plan, proposed car parking and service access

## C1.3.8 IN2 Light Industrial Zone

### Objective

- a) To provide for the orderly economic development of employment lands
- b) To provide industrial lots that are sufficient in size to cater for construction and building development, vehicle parking, access and loading facilities
- c) To provide streets that allow adequate access for industrial uses
- d) To ensure lots are adequately serviced

### Control

- 1) Lots are to front constructed roads
- 2) To ensure that adequate provision is made for two way vehicular access for future development to battleaxe lots:
  - the access handle for each lot must have direct frontage to a public road
  - the access handle must have a minimum width of 15m
  - a maximum of two lots only will be allowed to be accessed from one access handle

## C2 Residential development

The *QPRLEP2022* lists the type of residential development permitted in each land use zone and the definitions of types of residential development. A development application is required for all types of residential development. However, in some instances residential development may be 'complying development' - refer to *State Environmental Planning Policy (Exempt and Complying Development Codes) 2008* and *State Environmental Planning Policy (Housing) 2021*. Additionally, additions such as access ramps and decks may be exempt development under the *State Environmental Planning Policy (Exempt and Complying Development Codes) 2008*.

**Note:** The objectives and controls apply to both new residential developments and alterations and additions.

### C2.1 Objectives and controls applicable to all land use zones and dwelling types

#### Minimum information to accompany a development application

When lodging a development application, the following information is to be provided:

- site analysis as described in Part B1
- plans of the proposed residential development including all buildings, open space areas, car parking, entrances and internal roads

- applicable reports and plans that are required by other parts of this DCP, for example a landscape plan or on-site system of sewage management report

The following objectives and controls apply to all types of residential development in all land use zones, although some may be of greater relevance than others for example visual privacy is more likely to be of importance in a town or village environment than a rural area.

### Objective

- a) To maintain the character, amenity and environmental values of a locality
- b) To ensure that localities are pleasant places to reside
- c) To ensure that the infrastructure associated with residential development is appropriate
- d) To ensure the efficient use of land and infrastructure
- e) To maximise visual and acoustic privacy
- f) To provide useable outdoor spaces and landscaped areas around buildings
- g) To provide reasonable daylight and solar access to all buildings and outdoor spaces

## C2.1.1 Acoustic privacy

### Objective

- a) To minimise the impacts of noise transmission to habitable rooms and principal private open spaces of dwellings within and between sites

### Control

- 1) The impact of potential noise intrusion should be addressed in relation to compatibility with the ambient noise level at the relevant boundary of the site
- 2) Noise transmission should be reduced through the selection of building materials that reduce the amount of sound transmitted and room layout, for instance locate bedrooms away from roads
- 3) Site or enclose heat, water and pool pumps, air conditioners and the like to reduce noise transmission within and between dwellings
- 4) Setbacks may need to be greater than the minimum setback distances to meet the acoustic privacy objective

## C2.1.2 Visual privacy

### Objective

- a) To minimise the overlooking of habitable rooms and principal outdoor spaces of dwellings within and between sites

### Control

- 1) Dwellings should be sited and designed, particularly the internal layout to minimise the potential for overlooking into the habitable rooms and open space of adjoining properties.
- 2) Windows, especially first floor windows, should be sited so that they do not look directly into windows of habitable rooms of adjoining properties. Windows in the new development should be offset from the windows of buildings within the site and buildings on adjoining land
- 3) Design elements are to be used to increase visual amenity (for example recessed balconies, fencing and landscaping) and limit overlooking of lower dwellings or private open space
- 4) Setbacks may need to be greater than the minimum setback distances to meet the visual privacy objective

## C2.1.2 Adaptable housing

### Control

- 1) Refer to section B2.3 Adaptable housing in this DCP

## C2.1.3 Dwelling articulation

Refer to the Glossary in this DCP

### Objective

- a) To ensure that the facade treatment and architectural detail of dwellings enhances the character and continuity of the streetscape
- b) To reduce the apparent bulk and scale of dwellings
- c) To have contemporary designs which integrate with the visual elements of the streetscape

### Control

- 1) The maximum unarticulated dwelling length to a street is to be 5 metres
- 2) Large areas of blank or minimally articulated walls are to be avoided
- 3) Dwelling facades should be modulated to reduce the appearance of bulk and express elements of the buildings architecture
- 4) A mix of building materials and colours should be used to reduce the bulk of dwellings
- 5) Dwellings should be articulated on corner sites to address each street frontage and define prominent corners.
- 6) Dwellings in bushfire prone areas are to be designed in accordance with *Planning for Bushfire Protection 2006*

## C2.1.4 Dwelling exteriors

### Objective

- a) To ensure that residential development complements the character of the locality

### Control

- 1) Materials should be non-reflective to avoid glare
- 2) If recycled materials are to be used, materials should be structurally sound and appropriate to the locality of the development
- 3) Service pipes and vents should be concealed within the external walls where practicable

## C2.1.5 Development of a heritage item or in the vicinity of a heritage item

### Control

- 1) Where development is in the vicinity of a heritage listed item or is a heritage item refer to section B10.1 European heritage in this DCP. In respect of any development proposed within the state heritage listed area of 'Braidwood and its setting' refer to the *Braidwood Development Control Plan 2006*.

## C2.1.6 Driveways, entrances, access, parking and utilities

### Control

- 1) Refer to section B7 Engineering requirements in this DCP

## C2.1.7 Energy and water efficiency

Energy efficient homes appear very similar to conventional homes, but use the best combination of building orientation, wall and ceiling insulation, efficient water heating and space heating, efficient lighting and appliances. Energy consumption can be reduced by up to 40% when compared to a conventional home. Incorporating features such as the following into the design will increase the energy efficiency of the building:

- living areas and external courtyards should as far as practicable be orientated to the north or north east
- insulation of the building
- six star water devices

The NSW Government operates BASIX, the Building Sustainability Index. The Index aims to reduce the level of greenhouse gas emissions by setting energy and water reduction targets for dwellings. BASIX analyses this data and determines how it scores against the energy and water targets. The design must pass specific targets (which vary according to location and building type) before the user can print the BASIX Certificate. See also B17 Rainwater tanks.

Further information - [www.basix.nsw.gov.au](http://www.basix.nsw.gov.au)

**Note:** Solid fuel heaters are to be included in the BASIX assessment

### Objective

- a) To reduce energy and water consumption in new residential developments and those undergoing substantial alterations or additions

### Control

- 1) BASIX certificates are to be submitted with new all dwelling and alterations over \$50,000 development applications (refer to [www.basix.nsw.gov.au](http://www.basix.nsw.gov.au) to determine requirements)

## C2.1.8 Gates and fencing

Refer to section C30 Gates and Fencing in this DCP.

## C2.1.9 Height

The *QPRLEP2022* Height of Buildings Map shows the maximum height of buildings permitted in the Queanbeyan-Palerang local government area. Building height is defined in the *QPRLEP2022* Dictionary.

### Objective

- a) To ensure that dwelling heights reflect the local context and desired character of the street
- b) To ensure that the privacy of residential properties is protected

### Control

- 1) Dwelling heights are to be generally in keeping with that of neighbouring properties
- 2) Reasonable daylight and solar access must be available to all buildings and outdoor spaces. Refer to the Solar access objectives and controls below

## C2.1.10 Landscaping

### Control

- 1) Refer to section B12 Landscaping in this DCP



## C2.1.11 Overshadowing

### Objective

- a) To ensure that new residential development does not unreasonably diminish the amount of sunlight reaching existing developments and public open spaces

### Control

- 1) A reasonable level of sunlight is to be maintained between 9.00am and 3.00pm on 21 June to the following areas:
  - private open space within the development
  - private open space of adjoining buildings
  - public open space such as parks
  - solar water heaters on roofs and adjoining buildings
  - habitable rooms and recreation space in adjoining buildings
- 2) Council may require design changes to be undertaken where a proposed development is likely to cause undue overshadowing to the above areas
- 3) Shadow diagrams detailing shadows cast by the proposed development at 9.00am, 12.00pm and 3.00pm on 21 June may be required to demonstrate the impact
- 4) The extent of shadows is to take into account the range of factors that impact on solar access, including the slope of the land, aspect, existing and proposed vegetation and the height and position of existing buildings and structures, including fences

## C2.1.12 Solar access

Sunlight provides amenity and reduces energy providing environmental and financial benefits.

### Objective

- a) To have adequate sunlight to living areas and principal outdoor space of existing and proposed dwellings

### Control

- 1) Dwellings within the development site and adjoining properties are to be able to receive a minimum of 3 hours sunlight in habitable rooms and in at least 50% of the principal outdoor space between 9am and 3pm on 21 June
- 2) Where existing development currently receives less sunlight than the above requirement, this should not be reduced
- 3) Living areas of dwellings such as kitchens and family rooms should be located on the northern side of dwellings and service areas such as laundries and bathrooms to the south or west
- 4) Opportunities for passive heating and cooling of dwellings to reduce reliance on artificial heating and cooling should be maximised
- 5) To maximise solar access and to minimise overshadowing from adjoining buildings setbacks should be increased
- 6) To maximise solar access dwelling heights may need to be stepped

## C2.1.13 Siting and orientation

### Objective

- a) To ensure that dwelling siting and orientation reflects the characteristic pattern created by the original grid road layout where lots front the road (and laneway) and dwellings are generally oriented to the street

### Control

- 1) Dwellings are orientated and designed to address and overlook the public domain

- 2) Dwellings have an identifiable address to the primary street
- 3) Dwellings should be orientated to the north
- 4) Dwelling and driveways in residential areas should be located to take into account street trees

### C2.1.14 Roof form (shape)

#### Objective

- a) To ensure that roof forms do not significantly add to the bulk and scale of the building
- b) To ensure that roof forms respond to the scale and pitch of other roofs in the area

#### Control

- 1) The maximum roof pitch is to be 32 degrees
- 2) Attics within the roof space may be permitted where they do not unreasonably add to the bulk and scale of the building

### C2.1.15 Street frontage

#### Objective

- a) To ensure that the dwelling form and site layout reflects the characteristic street pattern

#### Control

- 1) The site is to be wide enough to achieve the following:
  - dwellings addressing the street
  - daylight and solar access
  - principal outdoor space
  - privacy
  - adequate vehicle access and accommodation
  - retention of significant trees, landscaping and soil planting

Minimum street frontage distances for most dwelling types are provided in the following sections.

### C2.1.16 Streetscape

#### Objective

- a) To ensure that the character of the street is maintained or enhanced by the contribution of the new residential development

#### Control

- 1) The proposed dwelling should fit comfortably within the existing streetscape of the area and scale of development

### C2.1.17 Tree and Vegetation Management

#### Control

- 1) Refer to section B3.5 Tree and Vegetation Management in this DCP

### C2.1.18 Unsewered sites

#### Control

- 1) Refer to section B13 On-site System of Sewage Management (OSSM) in this DCP

## C2.1.19 Potable water and sewage disposal

### Control

- 1) Refer to section B7 Engineering requirements in this DCP

## C2.2 Dwelling houses, secondary dwellings, semi-detached dwellings and dual occupancies in residential (R1, R2 and R5), business (B4) and RU5 Village land use zones

For the definitions of a dwelling house, secondary dwelling and dual occupancy refer to the Dictionary in the *QPRLEP2022*. Refer to Part 4 of the *QPRLEP2022* for the Erection of dwellings on land in certain residential, rural and environmental protection zones in the *QPRLEP2022* for the provisions relating to the erection of a dwelling house, secondary dwelling or dual occupancy.

Refer also to clause 4.2D Minimum lot sizes for dual occupancy development in the *QPRLEP2022*.

Some dwellings may be complying development, refer to the *State Environmental Planning Policy (Housing) 2021* or *State Environmental Planning Policy (Exempt and Complying Development Codes) 2008*.

### C2.2.1 Maximum gross floor area

Refer to the Dictionary in the *QPRLEP2022*.

#### Objective

- a) To limit the bulk and scale of a dwelling so that the rural character is maintained

#### Control

- 1) The gross floor area will be no greater than 40% of the area of the lot
- 2) The gross floor area (including the principal dwelling) of secondary dwellings, semi-detached dwellings and dual occupancies will be no greater than 40% of the area of the lot

### C2.2.2 Setbacks

Refer to the Glossary in this DCP.

#### Objective

- a) To establish the front building line to create consistent proportions of the street
- b) To maintain or enhance streetscape character through the continuity of street facades
- c) To enhance the setting for buildings through deep soil zones and landscaping
- d) To ensure visual privacy for residents

#### Control

- 1) Setbacks for each of the land use zones are shown in the table below:

**Note:** Setbacks which are part of a building envelope prevail

Table 13 Setbacks for dwelling houses

Setback distance (metres) for dwelling houses	R1	R2	R5	RU5	B4
Front	7 or the average of adjoining lots whichever is less, or 3 more than an adjacent historic structure	7 or the average of adjoining lots whichever is less, or 3 more than an adjacent historic structure	7 or the average of adjoining lots whichever is less, or 3 more than an adjacent historic structure	7 or the average of adjoining lots whichever is less, or 3 more than an adjacent historic structure	7 or the average of adjoining lots whichever is less, or 3 more than an adjacent historic structure
Side	0.9	0.9	15	0.9	0.9
Where the side is a street	3	3	15	3	3
Rear	0.9 if the building is less than 3.6 metres high otherwise 3	0.9 if the building is less than 3.6 metres high otherwise 3	15	0.9 if the building is less than 3.6 metres high otherwise 3	0.9 if the building is less than 3.6 metres high otherwise 3

## C2.3 Multi dwelling housing

For the definitions of multi dwelling housing refer to the *QPRLEP2022* Dictionary. The *QPRLEP2022* land use tables list the land use zones that permit multi dwelling housing and attached dwellings with consent.

### Objective

- To have well designed and varied housing forms that are integrated into the existing environment in terms of size, bulk, height, scale and setbacks
- To ensure that there is adequate, convenient and safe car parking that does not dominate the site or its streetscape
- To have open space areas which meet the needs of residents for outdoor leisure activities, privacy, landscaping and solar access
- To ensure that where there will be more than three dwellings, that some will be constructed as adaptable housing

### C2.3.1 Maximum gross floor area

Refer to the Dictionary in the *QPRLEP2022*.

### Objective

- To limit the bulk and scale of a dwelling so that the rural character is maintained
- To ensure that the form and massing of new development is compatible with the spatial characteristics of the area,
- To preserve significant trees and protect privacy and solar access for adjoining dwellings

### Control

- The gross floor area will be no greater than 66 % of the area of the lot

## C2.3.2 Setbacks

Refer to the Glossary in this DCP.

### Objective

- a) To establish the front building line to create consistent proportions of the street
- b) To maintain or enhance streetscape character through the continuity of street facades
- c) To enhance the setting for buildings through deep soil zones and landscaping
- d) To ensure visual privacy for residents

### Control

- 1) Setbacks for each of the land use zones are shown in the table below:

**Note:** Setbacks which are part of a building envelope prevail

Table 14 Setbacks for multi dwellings

Setback distance (metres) for multi dwellings	R1 General Residential
Front	4 or the average of adjoining lots
Side	0.9
Where the side is a street	3
Rear	0.9 if the building is less than 3.6 metres high otherwise 3

- 2) Where the entrance to a dwelling will be from a laneway dedicated to Council (refer to section B7.2 Urban Roads in this DCP), the minimum setbacks are to be taken from the rear boundary based on the lot boundary after the dedication of the laneway to Council

## C2.3.3 Site coverage

Site coverage means the area of a site containing any built structure (whether covered or uncovered), any building, car port, terrace, pergola, hard surface recreation area, swimming pool, tennis court, driveway, parking area, underground stormwater detention structure or any like structure but excluding minor landscape features.

### Objective

- a) To maintain or enhance the rural town character of residential areas
- b) To ensure that stormwater on the site is able to drain

### Control

- 1) No more than 50% of the site should be covered with buildings, hard surface recreation areas such as tennis courts, swimming pools, driveways and parking areas and paths

## C2.3.4 Adaptable housing

### Control

- 1) Refer to section B2.3 Adaptable housing in this DCP

## C2.3.5 Street frontage

### Control

- 1) The residential development must have frontage to a public road

- 2) The lot on which the development is proposed is to have a minimum street frontage of 25 metres

### C2.3.6 Site size

#### Control

- 1) The number of dwelling units permissible on each lot is based on lot area and the area required for each dwelling. The density is calculated by dividing the number of dwellings by the total area of residential land excluding roads. The following densities apply (maximum of one dwelling unit per indicated lot area):

Studio	150 m <sup>2</sup> lot area
one small dwelling unit (one bedroom)	250 m <sup>2</sup> lot area
one medium dwelling unit (two bedrooms)	350 m <sup>2</sup> lot area
one large dwelling unit (three or more bedrooms)	450 m <sup>2</sup> lot area

### C2.3.7 Building dimensions

#### Objective

- a) To ensure that dwellings have good internal amenity
- b) To reduce the bulk of buildings
- c) To ensure that dwellings are capable of being cross ventilated
- d) To ensure that dwellings are capable of receiving daylight access for light penetration and thermal comfort

#### Control

- 1) The maximum depth is to be 14m
- 2) The minimum width is to be 6m

### C2.3.8 Building separation

#### Objective

- a) To ensure visual and aural privacy for residents
- b) To maintain characteristic open spaces between buildings

#### Control

- 1) Building separation distances

Table 15 Building separation

minimum separation between buildings within the development site where habitable rooms face habitable rooms	12m
Minimum separation between buildings within the development site where habitable rooms face non-habitable rooms or blank walls	9m
Minimum separation between buildings within the development site where non-habitable rooms/blank walls face other non-habitable rooms/ blank walls	0m
Minimum separation between buildings within the development site where non-habitable rooms with windows face other non-habitable rooms (either with or without windows)	3m

## C2.3.9 Landscaping and landscape areas

### Objective

- a) To enhance the amenity of the development, assist in the management of stormwater and privacy

### Control

- 1) Landscaped areas not including vehicular access ways, car parking areas and drying areas shall be provided as follows:

Table 16 Minimum landscape areas

studio apartment	30m <sup>2</sup>
small dwelling (one bedroom)	65m <sup>2</sup>
medium dwelling (two bedroom)	90m <sup>2</sup>
large dwelling (three bedroom)	120m <sup>2</sup>

- 2) A landscaping plan is to be prepared. This plan is to be submitted with the development application and will form part of any approval granted by Council
- 3) Refer to section B11 Landscaping in this DCP

## C2.3.10 Communal Open Space

### Objective

- a) To ensure that the residential development has a contiguous, high quality, useable principal outdoor space that is integrated with the dwelling and affords a high degree of amenity in terms of privacy and solar access

### Control

- 1) An area of 100m<sup>2</sup> shall be provided for communal use. Where there will be more than three dwellings the area of communal open space should be increased at the rate of an additional 20 m<sup>2</sup> per additional dwelling
- 2) Communal open space is to be located with easy access to all dwellings on the site
- 3) Communal open space is to be landscaped and provided with recreational features such as a barbecue area, children's play area or landscape features. It should link with pedestrian paths
- 4) The location of the communal open space area is to take account of vehicle routes and the privacy of adjacent dwellings
- 5) Communal open space is to be oriented to the north to ensure adequate solar access

## C2.3.11 Private Open Space

Private open space means that part of the site not occupied by any buildings (except for swimming pools or other outdoor recreation facilities) which is landscaped by gardens, lawns, shrubs or trees and is available for the use of the occupants of the dwelling. This area is considered as part of the landscape area. Private open space does not include driveways, turning areas, car spaces, narrow elongated curtilage areas within the boundary setback areas, drying areas and service areas.

### Objective

- a) To ensure that each residence has private open space

### Control

- 1) An open courtyard of at least 50m<sup>2</sup> (minimum dimension 3 metres) shall be provided between the rear wall of each dwelling and the side or rear boundary. This area shall be considered as part of the landscape area. This area should be north facing and is to be designed and located

so as to provide maximum amenity for occupants. It is not to include service areas (water tanks, clothes drying areas and similar)

- 2) Private open space is to be located adjacent to primary living areas. Private open space should not be located adjacent to internal driveways
- 3) The design of the private open space should focus on the quality of the space in terms of its outlook, orientation, relationship to the dwelling, configuration, enclosure and landscape treatment
- 4) Areas within the front setback may be used for the private open space, provided that these areas are designed to ensure privacy without presenting solid high walls to the street

### C2.3.12 Service areas

Service areas encompass clothes drying, water tanks, pumps, metres and waste disposal areas

#### Objective

- a) To ensure that there is sufficient area for services in the residential development and that these are appropriately located

#### Control

- 1) External service areas for water tanks, pumps, garbage store, gas meters, laundries and bathrooms air conditioners and the like (excluding clothes drying areas) should be located to the south or west of the dwelling
- 2) External service areas must have a minimum area of 12 m<sup>2</sup>
- 3) External service areas should be separated from principal outdoor space and screens, vegetation, retaining walls and the like should be used to delineate areas

### C2.3.13 Clothes drying areas

- 1) Open air clothes drying facilities are to be provided for all dwellings
- 2) Clothes drying areas are to be easily accessible by all residents and screened from public streets and recreation areas

### C2.3.14 Waste and recycling facilities

- 1) A waste management plan for the construction and ongoing management of the development. The plan is to be submitted with the development application. Refer to Section B15 Waste Management in this DCP
- 2) A suitably constructed waste and recycling bin receptacle area is to be provided. It is to be positioned to afford ready access for both residents and garbage collectors

### C2.3.15 Toilet and garden maintenance storage area

- 1) Where there are more than ten dwellings in one development, a toilet for tradespeople and garden maintenance storage area is to be provided

### C2.3.16 Subdivision or consolidation of lots

The subdivision of a site includes a strata subdivision.

#### Control

- 1) The site amalgamation or subdivision should not disrupt the streetscape by changing the characteristic pattern of typical lots and buildings in a block
- 2) Subdivision requirements are detailed in section C1 Subdivision in this DCP



## C2.4 Residential flat buildings and shop top housing

For the definitions of residential flat buildings and shop top housing refer to the *QPRLEP2022* Dictionary. The *QPRLEP2022* land use tables list the areas that permit residential flat buildings with consent.

Developments which have three or more stories are required to comply with *State Environmental Planning Policy No 65—Design Quality of Residential Flat Development*.

### C2.4.1 Shop top housing

#### Control

#### C2.4.1.1 Entry

- 1) A separate pedestrian entry to the dwelling(s) is to be provided

#### C2.4.1.2 Commercial service requirements

- 1) Commercial service requirements such as loading docks are to be separate from residential access areas

#### C2.4.1.3 Private open space

- 1) Where private open space is not provided each dwelling is to be provided with a balcony.

#### C2.4.1.4 Storage areas

- 1) If a garage is not to be provided with a dwelling then a storage area will be required. The storage area is to be a minimum of 4m<sup>2</sup>

### C2.4.2 Residential flat buildings

#### Control

#### C2.4.2.1 Site frontage

- 1) The site should have a minimum width of not less than 25 metres at the front alignment of the building

#### C2.4.2.2 Setbacks

Front	4 m or the average of adjoining lots
Side	0.9 m
Where the side is a street	3 m
Rear	3 m

**Note:** Setbacks which are part of a building envelope prevail over these requirements.

#### C2.4.2.3 Floor Area

Refer to the Dictionary in the *QPRLEP2022*.

The gross floor area should be no greater than sixty six percent of the lot.

#### C2.4.2.4 Building dimensions

- 1) The maximum depth should not exceed 14m
- 2) The development shall be designed to provide attractive visual variation by the use of staggered building setbacks, variation of roof lines, curved driveways and access roads, landscaping and the like

#### C2.4.2.5 Building appearance

Dwellings should not be identical in design and façade treatment, but should be compatible with each other. If only a limited number of dwelling designs is to be used they should be so arranged on the site such that different façades are presented to any public place, communal area, or adjoining residential development.

#### C2.4.2.6 Number of storeys

To comply with the *QPRLEP2022* Height of Buildings Map, the building should not contain more than two storeys. However, the roof space may be utilised.

#### C2.4.2.7 Building entry

The main pedestrian entry to the building is to be provided facing the street, accessible directly from the street and clearly visible from the street.

#### C2.4.2.8 Service areas

Service areas encompass clothes drying, water tanks, pumps, metres and waste disposal areas

- 1) External service areas for water tanks, pumps, garbage store, gas meters, laundries and bathrooms air conditioners and the like (excluding clothes drying areas) are to be located to the south or west of the dwelling
- 2) External service areas must have a minimum area of 12m<sup>2</sup>
- 3) External service areas should be separated from principal outdoor space and screens, vegetation, retaining walls and the like should be used to delineate areas.

#### C2.4.2.9 Clothes Drying Areas

- 1) Suitably screened outdoor clothes line areas shall be provided. Clothes drying areas must be a minimum of 3m<sup>2</sup>.
- 2) Clothes drying areas must be capable of receiving northern solar access.
- 3) A minimum of 7.5m of clothes line is to be provided for each dwelling.

#### C2.4.2.10 Waste

A suitably constructed garbage bin receptacle shall be provided. It is to be positioned to afford ready access for both residents and garbage collectors

#### C2.4.2.11 Balconies

- 1) Balconies shall maintain setbacks for residential flat buildings.
- 2) No part of any means of enclosure of a balcony shall exceed a height of 1.2m

#### C2.4.2.12 Private open space

- 1) Private open space should be north facing.
- 2) Setback areas, courtyards and balconies are considered forms of private open space.

- 3) Setback areas, particularly the front areas, are to be designed to ensure adequate privacy without presenting solid high walls to the street.

### C2.4.2.13 Storage areas

If a garage is not to be provided with a dwelling then a storage area will be required. The storage area is to be a minimum of 4m<sup>2</sup>

## C2.5 Dwellings in RU1 Primary Production and C3 Environmental Management and C4 Environmental Living land use zones

### Objective

- To ensure dwellings are designed and sited so as to not detract from the rural landscape, scenic quality and agricultural productivity of rural areas
- To avoid development on environmentally constrained parts of the land
- To protect water courses, existing native vegetation and areas of heritage significance
- To provide buffers between residential buildings and land uses to minimise the potential for land use conflict.

### Control

#### C2.5.1 Setbacks

- 1) Setbacks for each of the land use zones are shown in Table 17 below:

Table 17 Setbacks for dwellings

Setbacks (metres) for dwellings		RU1 Primary Production	C3 Environmental Management	C4 Environmental Living
Primary road frontage		50	50	50
Side and rear	<4ha	15	15	15
	4ha- 80 ha	25	25	25
	> 80 ha	50	50	50
Watercourse		40	40	40
National park or nature reserve		100	100	100
Forestry, extractive industry, rural industry, intensive livestock industry		400	400	400

**Note:** Setbacks which are part of a building envelope prevail

#### C2.5.2 Potable water supply

- 1) Where a reticulated water supply is not available, a minimum potable water supply of 90,000 litres is to be provided and installed in accordance with B17 Rainwater Tanks

## C2.6 Rural workers dwelling

Clause 7.24 of the *QPRLEP2022* sets out the provisions in relation to rural worker's dwellings.

## Control

- 1) In addition to the information required in other sections in this DCP, documentary evidence is required to demonstrate that:
  - the rural property generates sufficient income to support an employee(s)
  - the rural property cannot operate without employee labour
  - on-site accommodation for an employee is essential to the operation of the rural property
  - off-site accommodation is unsuitable owing to the nature of the activity or the distance of the rural property from rental accommodation.
- 2) The rural workers dwelling is to be located within reasonable proximity to other farm buildings (e.g. within 300 m) but not so close as to cause land use conflicts

## C3 Affordable Housing

Affordable housing is housing that is within the financial means of low to medium income earners. In the last ten years the cost of housing in Australia has increased substantially compared with the level of income of individuals and households. This has resulted in a situation where governments at all levels are pursuing options which will allow individuals and families to access housing (both rented and purchased) that is within their financial means. It is generally considered that no more than thirty per cent of a weekly income should be spent on housing.

Clause 5 of the NSW *Environmental Planning and Assessment Act 1979* includes the following objective: (viii) the provision and maintenance of affordable housing.

### Objective

- a) To support the development of quality and affordable housing options, including boarding houses
- b) To locate affordable housing in areas that enable easy access to services and facilities
- c) To avoid a situation where cultural and social groupings are displaced or marginalised as a result of development

### Control

- 1) The development of dwellings in the urban areas of Bungendore and Braidwood should maintain and increase existing housing choice by incorporating a mix in the type and configuration of dwelling types
- 2) The following matters must be addressed in a development application for affordable housing:
  - the proximity of the dwellings to community and health services, recreational facilities, public transport to and from Bungendore or Braidwood and educational and retail facilities
  - whether the dwelling and associated private open space will be easily and affordably maintained
  - the availability of reticulated potable water and wastewater services
  - the gradient of the dwelling site and access to the site. The site and access should be able to be easily accessed by those with a physical disability. For example short steep driveways and roads are unsuitable for those in a wheelchair or those with poor balance/limited mobility
  - the site's susceptibility to natural hazards such as flood and bush fire.
- 3) Where a development is proposed to replace existing housing which is used by people who are considered to have a need for affordable housing, consideration will need to be given to future housing options for these people.

## C4 Exhibition homes and villages

The *QPRLEP2022* Dictionary defines exhibition homes and villages and provides the land use zones where they are permissible.

### Objective

- a) To ensure that the amenity of an area is not negatively impacted by factors such as traffic associated with exhibition homes and villages
- b) To accommodate future residential use of exhibition homes with appropriate infrastructure and amenity

### Control

#### C4.1 Exhibition home and village design

- 1) Exhibition homes and villages are to comply with C2 Residential Development within this DCP

#### C4.2 Location

- 1) Exhibition homes and villages should only be located in areas where the proposed development and ancillary activities are unlikely to cause a negative impact on the amenity of the area
- 2) Direct vehicle access from a classified road will not be permitted
- 3) Exhibition homes should be grouped within exhibition villages rather than distributed throughout urban areas.

#### C4.3 Occupation of dwellings

- 1) Exhibition homes are not to be occupied for residential use until the conclusion of the consent period for the exhibition home or exhibition village. A development application is required to change the use of the exhibition home or exhibition village to a dwelling.

#### C4.4 Hours of operation

- 1) The hours of operation for an exhibition village or exhibition home and any ancillary uses shall be restricted to between 9.00am and 6.00pm.

#### C4.5 Ancillary uses

- 1) Ancillary uses include sales offices, home financing offices and may also include public amenities such as a café and public toilets
- 2) All uses related to the development are to be ancillary to the operation of the exhibition home or village and must only service the needs generated by the development
- 3) Any ancillary uses to an exhibition home are to be contained within the curtilage of the exhibition home

## C5 Temporary residential accommodation

It is not permissible in any part of the former Palerang local government area to live in a temporary dwelling whilst a permanent dwelling is being constructed. However, a dual occupancy with consent may address this situation. Additionally, Section 68 of the *NSW Local Government Act 1993* permits a moveable dwelling in some circumstances.

## C6 Sheds, garages, carports and animal housing in residential and RU5 land use zones

The *QPRLEP2022* requires development consent for sheds and garages in residential and RU5 Village land use zones. However, in some instances development may be ‘exempt’ development – refer to *State Environmental Planning Policy (Exempt and Complying Development Codes) 2008*.

Minimum information to accompany a development application

When lodging a development application, the following information is to be provided:

- site analysis as described in Part B1
- plans of the proposed development including all other buildings, open space areas, carparking and entrances
- applicable reports and plans that are required by other parts of this DCP

### Objective

- To maintain and enhance the character and amenity of the residential areas
- To ensure that garages, carports and sheds are located to minimise the dominance of them in the streetscape

### Control

#### C6.1 Height

- The *QPRLEP2022* Height of Buildings Map shows the maximum height of buildings permitted in the Palerang local government area. Building height is defined in the *QPRLEP2022* Dictionary

#### C6.2 Setbacks

- Sheds, garages, carports and animal housing that are separate to the dwelling shall be set back from the front façade and designed so that the dwelling entry and façade are the dominant building features
- The setbacks for sheds, carports and garages in land use zones are:

Table 18 Setbacks for sheds

Setback distance (metres) for sheds	R1	R2	R5	RU5
Front	1m behind the existing building line	1m behind the existing building line	1m behind the existing building line	1m behind the existing building line
Side	0.9	0.9	15	0.9
Where the side is a street	3	3		3
Rear	0.9 if the building is less than 3.6 metres high otherwise 3	0.9 if the building is less than 3.6 metres high otherwise 3		0.9 if the building is less than 3.6 metres high otherwise 3

**Note:** Setbacks which are part of a building envelope prevail

#### C6.3 Garage frontage

- Where garages form part of the dwelling they shall not exceed 40% of the total width of the dwelling frontage

## C7 Business land development – B2 Local Centre and B4 Mixed Use

The *QPRLEP2022* contains a number of business land use zones including B2 Local Centre and B4 Mixed Use zones. Refer to the *QPRLEP2022* Land Zoning map for the location of these. Additionally, certain commercial developments may be permitted in other land use zones.

Character statements and specific controls which include the business land use zones apply to the centre of both Bungendore. Refer to section B10.1 European Heritage and section D Area Specific Provisions in this DCP.

In some instances, development may be exempt development. Refer to *State Environmental Planning Policy (Exempt and Complying Development Codes) 2008*.

### Objective

- a) To ensure that the development contributes positively to the streetscape and character of the locality.
- b) To ensure that the infrastructure associated with the development is appropriate.
- c) To ensure current solar access to all buildings and outdoor spaces is not reduced.

Minimum information to accompany the development application

When lodging a development application, the following information is to be provided:

- site analysis as described in Part B1
- the proposed use of the development
- the hours of operation
- the number of employees
- the plans of the proposed development including all buildings, open space areas, car parking, loading and unloading areas, entrances and any internal roads
- the number of vehicle movements per day
- landscaping plan detailing the following:
  - any existing vegetation to be retained relocated or removed
  - paved and grassed areas
  - planting scheme including trees, shrubs, grasses and groundcovers
  - water and maintenance schedules including drip irrigation and mulching details
- applicable reports and plans that are required by other parts of this DCP

### C7.1 Maximum gross floor area

#### Objective

- a) To minimise the scale and bulk of the building
- b) To ensure that the building fits within the rural character of the locality

#### Control

- 1) The maximum gross floor area will be no greater than 150% area of its lot. For commercial development this may increase where:
  - it is consistent with adjoining development and
  - adequate arrangements can be made for car parking, loading and unloading

## C7.2 Acoustic privacy

### Objective

- a) To minimise the impacts of noise transmission to rooms and principal private open spaces of and between sites

### Control

- 1) The impact of potential noise intrusion should be addressed in relation to compatibility with the ambient noise level at the relevant boundary of the site
- 2) Noise transmission should be reduced through the selection of building materials that reduce the amount of sound transmitted and room layout
- 3) Site or enclose heat, water and pool pumps, air conditioners and the like to reduce noise transmission within and between buildings
- 4) Setbacks may need to be greater than the minimum setback distances to meet the acoustic privacy objective

## C7.3 Building articulation

Refer to the Glossary for detail on this term.

### Objective

- a) To ensure that the facade treatment and architectural detail of buildings enhances the character and continuity of the streetscape
- b) To reduce the apparent bulk and scale of buildings
- c) To have contemporary designs which integrate with the visual elements of the streetscape

### Control

- 1) The maximum unarticulated building length to a street is to be 5m
- 2) Large areas of blank or minimally articulated walls are to be avoided
- 3) Building facades in plan and elevation should be modulated to reduce the appearance of bulk and express elements of the buildings architecture
- 4) A mix of building materials and colours should be used to reduce the bulk of buildings
- 5) Articulate buildings on corner sites to address each street frontage and define prominent corners

## C7.4 Building exteriors

### Objective

- a) To ensure that development compliments the character of the locality

### Control

- 1) Materials should be non-reflective to avoid glare
- 2) If recycled materials are to be used, materials should be structurally sound and appropriate to the locality of the development
- 3) Service pipes and vents within the external walls should be concealed where practicable

## C7.5 Building siting and orientation

### Objective

- a) To ensure that building siting and orientation reflects the characteristic pattern created by the original grid road layout where lots front the road (and laneway) and buildings are generally oriented to the street



## Control

- 1) Buildings should be orientated and designed to address and overlook the public domain
- 2) Buildings should have an identifiable address to the primary street

## C7.6 Energy efficiency

A *Building Code of Australia Section J Assessment* is required for all new commercial buildings. The Section J Assessment is required at Construction Certificate stage. However, consideration should be given at the development application stage, as meeting the Section J Assessment requirements may require modifications to the Development Application.

Consideration should also be given to NABERS (National Australian Built Environment Rating System), is a national scheme which measures the environmental performance of a building or Tenancy. NABERS provides four environmental rating tools: NABERS Energy, NABERS Water, NABERS Waste and NABERS Indoor environment. The scheme can be used to rate a range of buildings. NABERS is managed nationally by the NSW Office of Environment and Heritage, on behalf of Commonwealth, State and Territory governments.

## Objective

- a) To reduce energy, waste and water consumption in new commercial buildings developments or those undergoing significant alterations or additions

## Control

- 1) Office areas and external courtyards should, as far as practicable, be oriented to the north or north east
- 2) Where development proposals seek to use design and materials to achieve a high level of energy efficiency, applicants are encouraged to discuss the proposal with Council staff prior to submitting the development application

## C7.7 Height

The *QPRLEP2022* Height of Buildings Map shows the maximum height of buildings permitted in the Palerang local government area. Building height is defined in the *QPRLEP2022* Dictionary.

## Objective

- a) To ensure that building heights reflect the local context and desired character of the street
- b) To ensure that building heights are generally in keeping with that of neighbouring properties
- c) To ensure that privacy of residential properties is protected

## Control

- 1) Where a building is to be greater than two storeys, a transition in height is to be included

## C7.8 Setbacks

## Objective

- a) To maintain the character of the locality and enhance the streetscape

## Control

- 1) Setbacks are to be as follows, except for motels

Table 19 Setbacks for commercial buildings

Boundary	distance (metres)
front (except for corner lots)	Nil
corner lots	To be assessed relative to sight lines at the intersection and any traffic hazard that may be created
side	Nil
rear	Nil

Setbacks for motels are to be:

Table 20 Setbacks motels

boundary	distance (metres)
front (except for corner lots)	7
side street	6
side	3
rear	6

## C7.9 Roof pitch

### Objective

- a) To ensure that roof forms do not significantly add to the bulk and scale of the building
- b) To ensure that roof forms respond to the scale and pitch of other roofs in the area

### Control

- 1) Maximum roof pitch 32 degrees

## C7.10 Overshadowing

### Objective

- a) To ensure that building does not reduce existing sunlight to adjoining buildings

### Control

- 1) A reasonable level of sunlight to:
  - private open space within the development
  - private open space of adjoining buildings
  - public open space such as parks
  - solar water heaters on roofs and adjoining buildings
  - habitable rooms in adjoining buildings
  - a neighbour's habitable rooms and recreation space
 is to be maintained between 9.00am and 3.00pm on 21 June
- 2) Shadow diagrams detailing shadows cast by the proposed development at 9.00am, 12.00pm and 3.00pm on 21 June may be required to demonstrate the impact
- 3) Council may require design changes to be taken where a proposed development is likely to cause undue overshadowing to the above areas

## C7.11 Streetscape

### Objective

- a) To ensure that the character of the street is maintained or enhanced by the contribution of the development

### Control

- 1) The proposed building should fit comfortably within the existing streetscape of the village eg the character and scale of residential and other development within the vicinity

## C7.12 Waste management

### Objective

- a) To ensure all waste generated by development is contained and disposed of with minimal impact on the surrounding area.

### Control

- 1) The building design is to include a waste storage and recycling area that is roofed, graded and provided with water for cleansing. Refer to B15 Waste Management.

## C8 Industrial development

The *QPRLEP2022* permits light industry in zone IN2 Light Industrial. For the definition of light industry refer to the *QPRLEP2022* Dictionary.

Minimum information to accompany the development application

When lodging a development application, the following information is to be provided:

- site analysis as described in Part B1
- the proposed use of the industrial development and materials to be used in the industry
- the hours of operation
- the number of employees
- the expected noise levels
- plans of the proposed development including all buildings, open space areas, car parking, loading and unloading areas, entrances and internal roads.
- the number of vehicle movements per day
- landscaping plan detailing the following:
  - any existing vegetation to be retained relocated or removed;
  - paved and grassed areas;
  - planting scheme including trees, shrubs, grasses and groundcovers
  - water and maintenance schedules including drip irrigation and mulching details

### C8.1 Building Site Coverage

#### Objective

- a) To ensure industrial development is able to provide off-street parking and space for vehicle circulation, landscaping and open space
- b) To ensure that industrial development does not result in an overdevelopment of the site
- c) To contain the bulk and scale of industrial buildings

No controls have been set for these objectives. The development application should demonstrate that the objectives have been met.

## C8.2 Building Setbacks

### Objective

- a) To provide separation between industrial buildings and maintain an attractive streetscape
- b) To prevent land use conflict between industrial and other land uses and to ensure that the amenity of the area is not significantly impacted by industrial development
- c) To provide safe and efficient ingress and egress in and around industrial properties
- d) To provide sufficient space for landscaping
- e) To provide flexibility for good design

### Control

- 1) The minimum front setback is to be 5 metres. This allows for landscaping
- 2) Side and rear setback, where the adjoining land is residential land the minimum setback is to be 5 metres

## C8.3 Building Design

### Objective

- a) To minimise the impact of industrial development on the locality and adjoining land-uses
- b) To provide building designs that are easily identifiable and readily located from public roads
- c) To encourage innovative technologies into new developments to reduce ongoing water and energy use and maintenance costs

### Control

- 1) Development in the vicinity of a heritage listed item. Refer to section B10.1 European heritage in this DCP

## C8.4 Height

### Control

- 1) The height of any industrial building is to be in accordance with the *QPRLEP2022* Height of Buildings Map.

## C8.5 Visual Amenity, Materials, Colours and Finishes

### Control

- 1) External facades (including roofs) shall use material, colours and finishes that will not be reflective or cause the sun to reflect off surfaces onto other properties and roads.
- 2) Darker colours are recommended as they are more likely to blend in with the surrounding vegetation

## C8.6 Design and Appearance

### Control

- 1) The use of passive solar energy and ventilation in the design of the building is encouraged. Development should consider building design and operation measures that reduce energy consumption relative to conventional buildings. These measures could include:
  - free-spinning ventilation ducts
  - using hand operated louvres
  - effective use of vertical and horizontal cross-flow ventilation
  - use of renewable energy sources such as solar heat pump water systems

- use of renewable or recycled building materials
  - insulation of roof and walls to Australian Standards
  - use of sustainable energy technologies such as photo-voltaic cells, co-generation or (roof mounted) wind turbines
- 2) Water conservation principles are to be incorporated into the design of new buildings to minimise reliance on reticulated water.
  - 3) Devices used in the functioning of the building, such as mechanical ventilation and air conditioning plant, ventilation ducts, hoppers, waste storage containers and the like are to be located towards the rear of the property or suitably screened so they cannot be seen from a public place.
  - 4) Any external lighting for a building (including security lighting) must be directed towards the site from the property boundaries. Any lighting fixed to buildings must contain 'Light Spill' to within the property boundaries by the use of barn doors (shutters). It is recommended that night-time security lighting be operated by motion sensors set to extinguish lighting within a reasonable timeframe

## C8.7 Signage

- 1) Signage must comply with the Signage section in this DCP, *State Environmental Planning Policy (Exempt and Complying Development Codes) 2008* and the *QPRLEP2022*. Refer to C18 Advertising Signage.

## C8.8 Access and Parking

### Objective

- a) To maintain traffic circulation on industrial properties
- b) To minimise disruption to through traffic
- c) To ensure traffic generated by industrial development does not detrimentally affect local or regional traffic movements
- d) To make entrances and exits of properties easily recognisable to visitors
- e) To minimise the potential congestion or hazard on adjoining roads at points of ingress/egress
- f) To discourage the use of streets for the parking of vehicles associated with new developments

### Control

#### C8.8.1 Parking

- 1) Parking shall be provided at the rate determined section B7.1- Parking in this DCP. Parking spaces shall be provided in accordance with the requirements of the *Roads and Traffic Authority Guide for Traffic Generating Developments*
- 2) Parking areas are to comply with *Austrroads Guidelines for Planning and Assessment of Road Freight Access in Industrial Areas*

#### C8.8.2 Access

- 1) Entrances and buildings shall be clearly identified by signage, landscaping or fence treatment or have a featured surface
- 2) Ingress and egress where possible is to be gained from a public road
- 3) Where driveways are located on a main road, gates from front boundaries are to be indented to provide a holding area for vehicles when the gates are closed. The desirable minimum depth should cater for a six-metre vehicle. However, this length may need to be increased depending on the use of the building(s) and the type of vehicles using the site
- 4) All vehicles are to enter and leave the site in a forward direction

- 5) Entrances and internal roads are to comply with *Austrroads Guidelines for Planning and Assessment of Road Freight Access in Industrial Areas*
- 6) All access points fronting a public road must be recessed

## C8.9 Loading and Unloading facilities

### Control

- 1) Developments with a gross leaseable floor area of:
  - less than 1,000 m<sup>2</sup> must be designed for the manoeuvring of a medium rigid vehicle as defined by *AS2890.2: 2004*
  - more than 1,000 m<sup>2</sup> must be designed for the manoeuvring of a heavy rigid vehicle as defined by *AS2890.2: 2004*
  - all development sizes requiring articulated vehicle access must be designed for the manoeuvring of an articulated vehicle as defined by *AS2890.2:2004*
- 2) In order to prevent or reduce vehicle turning movements on-site, loading and unloading areas must be located with easy access to entrances, exits and loading docks
- 3) Sufficient area shall be provided on-site for the queuing/parking of service vehicles
- 4) Vehicle loading and unloading facilities should be separated from passenger vehicle and pedestrian circulation paths and vehicle parking areas
- 5) All service vehicles must be parked wholly within the site at all times
- 6) Loading and unloading areas are to comply with *Austrroads Guidelines for Planning and Assessment of Road Freight Access in Industrial Areas*

## C8.10 Vehicle/Pedestrian circulation

### Control

- 1) Vehicle and pedestrian circulation paths must be separated to reduce safety risk. It is recommended that pedestrian paths be incorporated into landscaping and hard surfaced. Pedestrian pathways incorporated into landscaping can be included in landscape area calculations.

## C8.11 Waste management

- 1) The building design is to include a waste storage and recycling area that is roofed, graded and provided with water for cleansing. Refer to B15 Waste Management.

## C8.12 Industrial Open Areas and Landscaping

### Objective

- a) To provide open areas that are landscaped and incorporated into the design of the site
- b) To provide landscaping that softens and screens the visual impact of industrial structures, infrastructure, storage areas and large expanses of hard paved surfaces from residential and environmentally sensitive areas
- c) To provide robust and low maintenance noninvasive landscaping within developments that contribute to water efficiency and reduces airborne pollutants
- d) To promote landscape and outdoor amenity within developments particularly for employees and visitors in terms of views, aesthetics, microclimate and outdoor areas
- e) To protect and maintain existing mature trees where possible
- f) To respect the residential interface.

## Control

### C8.12.1 Minimum Landscape Area

- 1) Sections B1 Site Analysis and B12 Landscaping of this DCP should be consulted when considering site layout and the contribution landscaping makes to the visual appearance and functioning of a site

### C8.12.2 Fencing

Some fencing may be exempt development under the State Environmental Planning Policy (Exempt and Complying Development Codes) 2008.

Refer to section C30 Gates and Fencing in this DCP

## C9 Restaurants or cafés in RU1 Primary Production or C4 Environmental Living

The land use Restaurants or cafes is defined in the *QPRLEP2022*.

### Objective

- a) To maintain the rural amenity of the land use zones RU1 Primary Production or C4 Environmental Living

### Control

- 1) Restaurants or cafes should be sited away from visually prominent areas and a minimum of 100 metres from dwellings on adjoining properties

**Note:** It is suggested that applicants consider other sections of the DCP including waste, parking, noise, food, visual amenity and access

## C10 Eco-tourist facilities

The *QPRLEP2022* permits eco-tourist facilities in zones C3 Environmental Management and RU1 Primary Production. The definition of an eco-tourist facility is provided in the *QPRLEP2022* dictionary.

Minimum information to accompany the development application

When lodging a development application, the following information is to be provided:

- Site analysis as described in Part B1
- Information in relation to clause 5.13 of the *QPRLEP2022*.
- The maximum number of guests
- Plans of the proposed facility, indicating all internal uses and the number and location of the proposed guest rooms. External facilities such as lighting that could impact on the amenity of adjoining properties or the natural environment should be shown on the plans
- The location and dimensions of car parking and internal roads
- Details of the management of waste and sewage and the means by which potable water will be obtained
- Details of power and telecommunication facilities

### Objective

- a) To ensure that the requirements of clause 5.13 of the *QPRLEP2022* are met
- b) To ensure that appropriate health and safety standards are met

## Control

### C10.1 Access

- 1) Internal roads and the entrance to the eco-tourism facility should minimise the fragmentation of environmentally sensitive land

### C10.2 Car Parking

- 1) On-site car parking must be provided in accordance with the *RTA Guide to Traffic Generating Development Version 2.2*
- 2) All parking must be provided in accordance with *Australian Standard for Parking Facilities 2890*
- 3) On-site car parking shall be constructed and located so as to minimise the noise, light and dust from vehicles entering and leaving the site
- 4) Vehicles are to enter and leave the property in a forward direction. Refer to B7.1 Car parking

## C11 Bed and Breakfast Accommodation

Provisions relating to Bed and Breakfast Accommodation are contained in the *QPRLEP2022*.

As this type of development can impact on the amenity (aural and visual) of an area the assessment of a development application will take into consideration the degree to which the proposal is compatible with the existing and desired future amenity and character of the area.

### Objective

- a) To ensure that the dwelling, although accommodating a secondary use, maintains its residential scale and appearance when assessed against surrounding dwellings and streetscape
- b) To ensure that the development, including outbuildings and parking areas, remains residential in character and reflects the character of development in the surrounding area
- c) To ensure that appropriate health and fire safety standards are met

### Development Guidelines

- The Local Government and Shires Association of NSW has published a document titled *Guidelines for Bed and Breakfast Operations – Best practice assessment and policy guidelines for use by Local Government and the Bed and Breakfast industry in NSW*. It is advisable to obtain a copy of these guidelines (or a subsequent publication) to assist in designing and establishing the Bed and Breakfast Establishment
- It is advisable to contact the Bed and Breakfast Council of NSW for advice on best practice industry standards

### Information to accompany the development application

When lodging a development application, the following information is to be provided:

- site analysis as described in Part B1
- plans of the existing dwelling house, indicating all internal uses including the permanent residents' accommodation and the number and location of the proposed guest rooms. External facilities such as air conditioning and lighting that could impact on the amenity of adjoining properties should be shown on the plans
- the location and dimensions of additional buildings and structures other than the principal dwelling, and car parking areas on site
- a traffic and parking impact statement is required to be submitted to Council as part of the development application
- details of any proposed works not included in the above
- the name of the operator of the establishment



## Control

### C11.1 Development and Design

To achieve the objectives described above and address the development guidelines, the development shall comply with the following controls:

- 1) Overnight accommodation shall be contained wholly within the principal dwelling
- 2) Ancillary development provided as part of the Bed and Breakfast facility, such as recreation facilities, gazebos, swimming pool, shall be located on the same lot as the principal dwelling
- 3) Ancillary development provided as part of the Bed and Breakfast facility, such as recreation facilities, gazebos, swimming pool, shall be of a scale that ensures that the principal dwelling remains the primary land use on the site and that residential development remains the dominant land use in keeping with the surroundings

### C11.2 Operational Matters

- 1) The proprietor and operator of a dwelling offering Bed and Breakfast Accommodation must be a permanent resident of the property
- 2) The Bed and Breakfast Accommodation must be for short-term guests occupying the premises for a maximum of two calendar week at a time
- 3) A maximum of 3 bedrooms shall be available for guests
- 4) Guest bedrooms shall accommodate a maximum of two adults per room
- 5) A trade waste agreement will be required when the bed and breakfast accommodation is to be connected to Council managed sewerage system

### C11.3 Access for people with a disability

- 1) Areas to be used by guests should be directly accessible and without unnecessary barriers
- 2) Stairs and ramps should have lesser gradients and non-slip, even surfaces in accordance with *Australian Standards for the Design for Access and Mobility*
- 3) The principal point of entry and a bathroom accessible to guests should be designed for disabled access, in accordance with current *Australian Standards for the Design for Access and Mobility*

**Note:** This development may trigger the Disability Code

### C11.4 Car Parking

Safety and convenience are the principal parking and access issues. Entering and leaving Bed and Breakfast Accommodation should be safe for visitors, other road users and pedestrians who may be unfamiliar with the establishment. Parking is to be convenient for visitors without inconveniencing adjoining neighbours or other road users.

To meet these requirements, the following controls apply:

- 1) In addition to permanent resident parking, on site car parking must be provided at the rate of 1 space per guest bedroom plus one 1 space per 2 employees in accordance with *Australian Standard 2890*
- 2) At least one 1 car parking space should be designed for people with a disability, in accordance with the relevant *Australian Standard for Parking Facilities 2890.6*.
- 3) On-site car parking shall be constructed and located so as to minimise the noise, light and dust from vehicles entering and leaving the site
- 4) No more than 50% of the property located between the main building and the front property boundary shall be occupied by off-street car parking spaces, including access driveways. Such space shall be suitably screened with appropriate landscaping

- 5) Vehicles are to enter and leave the property in a forward direction

## C12 Outdoor Dining

Outdoor dining provides the opportunity to generate a pleasant and relaxed atmosphere within commercial areas. However, tables and chairs need to be placed in a location that does not impede pedestrian movement or place diners in an unsafe area.

Approval for outdoor dining is required. One or more of the following Acts may apply.

Before an approval can be issued for outdoor dining, the business must have development consent.

If the outdoor dining area is associated with a business that has a current development approval for example a café or restaurant for a certain number of tables and chairs and the placement of some of the tables and chairs on the footpath will not involve an increase in the total number of tables and chairs, there will be no need for a new development application. However, if the outdoor dining area will increase the number of tables and chairs permitted by a current development approval, then a new or modification of the development application will be required (depending on the extent of change to the existing development approval).

**Note:** Development contributions under Section 7.11 or Section 7.12 of the *NSW Environmental Planning and Assessment Act 1979* may apply. Refer to section A13 in this DCP

### NSW Local Government Act 1993

If the outdoor dining area will be on land classified as community land under the *NSW Local Government Act 1993* or a footpath, then approval will be required under either:

- Part D Community land, 1 Engage in a trade or business
- Part E Public roads, 2 Expose or allow to be exposed (whether for sale or otherwise) any article in or on or so as to overhang any part of the road or outside a shop window or doorway abutting the road, or hang an article beneath an awning over the road

Under Section 46 of the Act, Council will charge of fee for the use of community land.

### NSW Roads Act 1993

Under the *NSW Roads Act 1993*, Council is the regulatory authority for ensuring public safety on roads (including footpaths). Where the footpath is part of a classified road, the NSW Roads and Maritime Services has a concurrence role. Approval from the road authority to use the footpath for restaurant purposes is required under Section 125 of the Act and if a permanent structure such as seating is to be erected, additional approval will be required under section 138 of the Act.

**Note:** Malbon Street, Bungendore is a classified road as it is part of the Kings Highway.

Under Section 125 of the Act, Council will charge an annual fee for the use of the footpath.

### Exempt development

In some instances the dining area may be exempt development under the State *Environmental Planning Policy (Exempt and Complying Development Codes) 2008*.

**Note:** If the proposed dining area is exempt development, consent is still required under the

- *NSW Local Government Act 1993*
- *NSW Roads Act 1993*

### Minimum information to accompany a development application

Outdoor dining areas require the following information:

- a development application (if the number of tables and chairs is to be increased or there is no development approval for a café or restaurant)

- if the development application is to establish a food premises or to increase the number of tables and chairs on an approved developed application for a food premises, the following information will also be required:
  - documentation showing that the food preparation area meets the applicable standards
  - proposed waste management strategies
  - licence application for consent under Section 125 of the *NSW Roads Act 1993*, Section 138 of the *NSW Roads Act 1993* if a permanent structure is to be erected on the footpath and Section 68 of the *NSW Local Government Act 1993*
  - the accompanying information is required:
    - a plan drawn to a scale of 1:100 showing:
      - the outdoor area to be used (include dimensions and any features such as trees and posts)
      - the distance of the outdoor furniture, barriers and any other associated equipment from property boundaries
      - location and number of chairs, couches and tables (specify type and size)
      - the area to be maintained for public access
      - the relationship of the outdoor dining area to the existing business
      - the type of furniture to be used (design, materials and colours )
      - temporary features such as fencing, heaters and pot plants
      - details of advertising structures
      - details of whether alcohol will be provided. If alcohol is to be provided, a copy of the liquor licence is to be provided
  - details of any menu board (if one is to be used)
  - details of trading hours
  - a copy of a certificate of currency for public liability insurance for a minimum of twenty million dollars
  - the consent of the property owner (in most instances this will be Council or the NSW Roads and Maritime Service)

### Objective

- a) To ensure that the dining area contributes to a friendly atmosphere and a pleasant street amenity which will encourage pedestrians to use the area
- b) To ensure that a clear passageway for pedestrians that is free of interference or intimidation is provided
- c) To ensure that the dining area is safe and that it contributes to the streetscape in a positive manner
- d) To ensure that the dining area does not impact negatively on the amenity of adjoining properties

### Control

- 1) The outdoor dining area must occupy an area of footpath adjacent to an approved restaurant or other approved premises, where the use of such footpath is directly related to the operation of the business. 1800 mm on the footpath is to be maintained as a pedestrian thoroughfare
- 2) All furniture and equipment is to be placed in the arrangement shown below. The arrangement will depend on the ability to comply with the following:
  - a minimum total footpath width of 3 metres
  - the dining area is outside the premises to which it relates

Figure 14 Preferred location for outdoor dining

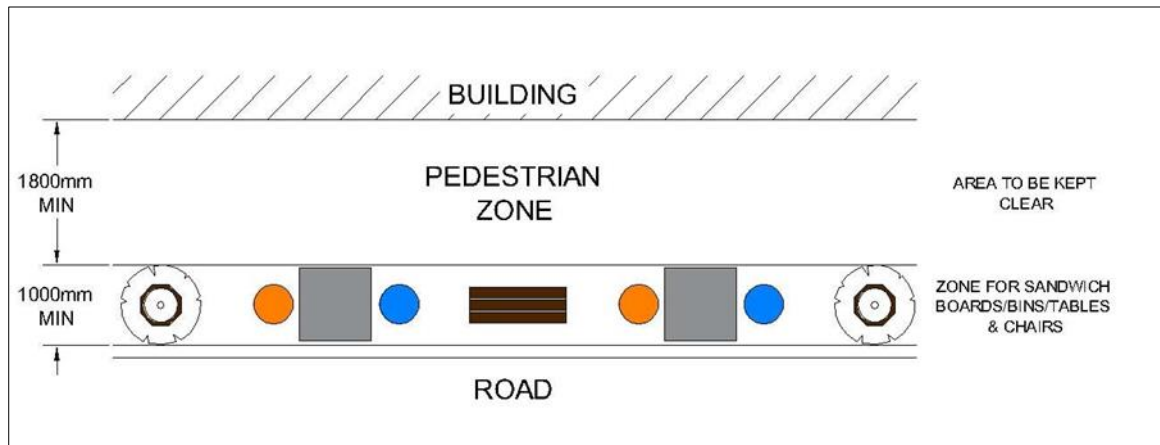

- 3) The ground surface is to be suitably constructed and sufficiently level to accommodate outdoor furniture and enable the area to be used safely and without inconvenience to pedestrians or vehicles
- 4) The boundaries of the outdoor dining area are to be marked either by removable bollards, pavement markers, fencing or planter boxes
- 5) Street barriers used to define seating areas are to be stable and should not contain any fixtures that will cause any trip hazards
- 6) Permanent barriers may be required to protect patrons from vehicular traffic
- 7) Furniture is to be removed at the close of business every day and must be of a sturdy and attractive nature
- 8) Outdoor are to be used in accordance with *Smoke Free Environment Act 2000*
- 9) There are to be no hazards across the footpath, for example power cords and street furniture barriers

## C13 Roadside Stalls

Roadside stalls are permissible with consent in some land use zones. Refer to the *QPRLEP2022* Dictionary for the definition of roadside stalls. A development application will be required to be submitted to Council. If the roadside stall is to be located on a property which fronts a classified road, the development application will be referred to NSW Roads and Maritime Services.

Clause 5.4 of the *QPRLEP2022* sets the maximum gross floor area of roadside stalls.

### Objective

- a) To ensure that roadside stalls are appropriately located such that patrons' parking and movement around the stall does not present a danger to themselves or passing traffic
- b) To ensure that roadside stalls are designed to be easily cleaned and maintained and remain an attractive feature of the rural landscape.

### Minimum information to accompany the development application

- a site plan illustrating the proposed location (including Lot and Deposited Plan number and road name) of the roadside stall and parking area
- the dates and hours of operation
- the goods to be sold

### Control

- 1) The stall is to be located within the property boundary
- 2) The stall is to be located at a point which does not impede the line of sight of passing traffic

- 3) The stall is to be located where associated roadside parking poses no potential danger to passing traffic, parked cars or stall patrons. Bus bays are not to be used
- 4) The stall is to be constructed of non-reflective materials which complements the surrounding environment
- 5) The stall is to be constructed so that food produce is protected from weather extremes so that it remains safe for consumption
- 6) The stall is to be properly maintained to ensure that it remains clean and attractive
- 7) If food produce is being sold, the preparation and storage of it must comply with the *NSW Food Act 2003*

## C14 Use of the footpath

In addition to outdoor dining, footpaths can be used for the display of merchandise, busking and temporary uses of public spaces such as the selling of raffle tickets.

Council is responsible for the effective management of footpath areas and requires that activities using the footpath obtain consent.

Consent for the display of merchandise, busking and temporary uses of public spaces is required under each of the following Acts:

- Section 68 *NSW Local Government Act 1993*
- *NSW Environmental Planning and Assessment Act 1979* (in some instances)
- *Section 125 NSW Roads Act 1993*

Under the *NSW Roads Act 1993*, Council is the regulatory authority for ensuring public safety on roads (including footpaths). Where the footpath is part of a classified road, the NSW Roads and Maritime Authority has a concurrence role.

**Note:** Malbon and Molonglo Streets Bungendore are a classified road as it is part of the Kings Highway

### Objective

- a) To ensure that the footpath area being used contributes to a friendly atmosphere and a pleasant street amenity which will encourage pedestrians to use the area
- b) To ensure that a clear passageway for pedestrians is free of interference or intimidation is provided
- c) To ensure that the footpath area being used is safe and contributes to the streetscape in a positive manner
- d) To ensure that the activity does not impact negatively on the amenity of adjoining properties

### C14.1 Footpath merchandise displays

#### Minimum information to accompany an application

The following information will be required for an application for footpath merchandise displays

- a development application (if the display will have a significant impact on the footpath area)
- licence application for consent under Section 125 of the *NSW Roads Act 1993*, Section 138 of the *NSW Roads Act 1993* if a permanent structure is to be erected on the footpath and Section 68 of the *NSW Local Government Act 1993*
- a description of the merchandise display structure (including height, width and materials)
- details of the days and hours the display structure is to be used
- a copy of a certificate of currency for public liability insurance for a minimum of 20 million dollars

- the consent of the property owner (in most instances this will be Council or the NSW Roads and Maritime Services)

### Control

- 1) A 1.8m wide clear passage of travel for pedestrians
- 2) Displays are to be stored within the business premises when the business is closed
- 3) Displays are to be removed from the footpath within 30 minutes of the close of business

### C14.1.2 Displays

- 1) The stand or display is not to occupy more than 1.5m<sup>2</sup> for each 6 metres of shop front and is not to exceed a maximum width of 600mm
- 2) Displays must be a minimum of 750mm in height above the footpath with solid fronts and sides
- 3) Display boxes or plinths must be a minimum 300mm in height above the footpath.
- 4) No plant or product may be placed directly on the footpath
- 5) Displays are not to occupy more than 50% of the shop front
- 6) Headline wire frame displays must be fixed to the wall, off the ground, not freestanding

### C14.1.4 Hanging articles or baskets

- 1) A minimum clearance of 2.1m above the footpath is required
- 2) Articles are not to unreasonably obscure pedestrian viewing of signs of adjacent shops

### C14.2 Busking

Minimum information to accompany an application

- a description of the busking act
- the day and time the act is to take place
- a copy of a certificate of currency for public liability insurance for a minimum of 20 million dollars
- the consent of the property owner (in most instances this will be Council or the NSW Roads and Services Authority)
- Parental consent if the performer is under 18 years of age
- a development application (if the display will have a significant impact on the footpath area)
- licence application for consent under Section 138 of the *NSW Roads Act 1993* and Section 68 of the *NSW Local Government Act 1993*

### Control

- 1) Performances must at all times contain material suitable for a family audience. The use of offensive, threatening, abusive, racist or discriminatory language or gestures will not be tolerated
- 2) A Busker shall not perform by means of a loud speaker or any form of sound amplification or by means of electricity amplified instruments.
- 3) Display structures must not be used. i.e. A frames
- 4) Collection of money must be done in an acceptable manner. Members of the public must not be harassed. No soliciting of funds.
- 5) The use of dangerous implements or materials is not permitted unless an assessment of the act, dangerous materials and competency of the performer has been undertaken

### C14.3 Other temporary uses of public spaces

Festivals, street parades, markets and concerts will possibly require development consent under the *NSW Environmental Planning and Assessment Act 1979*. Refer to section C20 Events in this DCP. Activities such as selling raffle tickets require the consent of Council.

Minimum information to accompany an application

- a description of the temporary use
- the day and time the temporary use is to take place
- a copy of a certificate of currency for public liability insurance for a minimum of 20 million dollars
- the consent of the property owner (in most instances this will be Council or the NSW Roads and Services Authority)
- a development application (if the use of the footpath will have a significant impact on the area)
- licence application for consent under Section 138 of the *NSW Roads Act 1993* and Section 68 of the *NSW Local Government Act 1993*

#### Control

- 1) The activity is not to be of a noisy, dangerous or offensive nature

### C14.4 Food Vans

In some instances, Mobile Food Vans may be exempt development. Refer to State Environmental Planning Policy (Exempt and Complying Development Codes) 2008.

#### Objective

- a) To mitigate the impact on existing businesses.
- b) To allow mobile food vans to operate in suitable locations

Minimum information to accompany an application

- a description of the use
- the day and time the mobile food van is to operate
- a copy of a certificate of currency for public liability insurance for a minimum of 20 million dollars
- the consent of the property owner (in most instances this will be Council or the NSW Roads and Services Authority)
- a development application (outside of the *State Environmental Planning Policy (Exempt and Complying Development Codes) 2008*)
- licence application for consent under Section 138 of the *NSW Roads Act 1993* and Section 68 of the *NSW Local Government Act 1993*

#### Control

- 1) The activity is not to be of a noisy, dangerous or offensive nature
- 2) All Mobile Food vans are to comply with all applicable regulations that 'regular' food businesses are required to comply with

## C15 Swimming pools

Private or 'backyard' swimming pool safety is legislated by the *Swimming Pools Act 1992*. The legislation also applies to moveable dwellings, hotels and motels.

The *Swimming Pools Act 1992* defines a swimming pool as being  
*an excavation, structure or vessel:*

- a) that is capable of being filled with water to a depth of 300 millimetres or more, and
- b) that is solely or principally used, or that is designed, manufactured or adapted to be solely or principally used, for the purpose of swimming, wading, paddling or any other human aquatic activity, and includes a spa pool, but does not include a spa bath, anything that is situated within a bathroom or anything declared by the regulations not to be a swimming pool for the purposes of this Act.

**Note:** This definition includes portable pools

The development of a swimming pool requires development consent. In some instances the development may be complying or exempt development under the *State Environmental Planning Policy (Exempt and Complying Development Codes) 2008*.

### Objective

- a) To ensure that swimming pools are safe and do not negatively impact the amenity of an area

### Control

- 1) The *Swimming Pools Act 1992*, requires all pools to be provided with approved fencing and other approved 'child-resistant' barriers. The fencing, signs and barriers must comply with the current version of *AS 1926, Swimming pool safety - Safety barriers for swimming pools*
- 2) All swimming pools should be fitted with a cover to minimise water loss through evaporation
- 3) Pool pumps should be located away from adjoining properties so that the requirements of the *Protection of the Environment Administration Act 1991* are met
- 4) The pool is to be registered in accordance with Council's swimming pool policy

### Further information

NSW Division of Local Government – Backyard swimming pools at [www.dlg.nsw.gov.au](http://www.dlg.nsw.gov.au)

## C16 Shipping Containers

Shipping Containers are considered a 'building' under the NSW *Environmental Planning and Assessment Act 1979* and they will require development consent. However, in some instances they may be exempt development under the *State Environmental Planning Policy (Exempt and Complying Development Codes) 2008*. The purpose for which the shipping container is to be used is required to be permissible under the *QPRLEP2022*.

As shipping containers are considered a building and they a construction certificate. Shipping containers are to be included in the floor space ratio calculation of a development in Residential and Business zones.

Minimum information to accompany the development application

When lodging a development application, the following information is to be provided:

- site analysis as described in Part B1
- the proposed use of the container
- the proposed colour(s)
- details of how they container will be tied down

### Objective

- a) To maintain the amenity of an area
- b) To ensure that the use of the containers is appropriate for the location

### Control

- 1) The General Provisions of the this DCP must be complied with
- 2) Where the container is to be used for residential accommodation consent is to be obtained for this purpose



- 3) Containers must not be located over utility areas or over effluent treatment disposal areas or systems
- 4) Containers in zones R1 General Residential, R2 Low Density Residential, R5 Large Lot Residential and RU5 Village must be behind the building line and must not be visible from the street. A vegetation screen may be used. Details of the proposed location and any screening are to be submitted with the development application. Containers must not be located any closer than one metre from side or rear boundaries. Where the lot has a building envelope, the entire shipping container must be located within the building envelope
- 5) Containers in zone RU1 Primary Production, E2 Environmental Conservation, C3 Environmental Management, C4 Environmental Living must not be located within 50 metres of the front, side or rear boundaries
- 6) Containers in zones B2 Local Centre and B4 Mixed Use are to be screened
- 7) Containers must be painted a neutral colour to blend with the surrounding natural environment and built structures. The proposed colour is to be included with the development application
- 8) Containers are not to be placed in flood planning areas
- 9) Containers that will be used for storage purposes are not to be stacked
- 10) Containers will not be permitted in a Heritage Conservation Area or on lots containing a heritage item unless they are approved on a short-term basis (less than 2 years) in conjunction with an approved development application and construction certificate for specific works

## C17 Lighting

Lighting used in association with facilities such as horse arenas, tennis courts and swimming pools may result in a loss of amenity for adjoining properties.

### Objective

- a) To ensure that lighting does not adversely impact on surrounding development
- b) To ensure that lighting does not create 'twilight' impacts on the surrounding environment
- c) To ensure that lighting does not significantly diminish the quality of the night sky

### Control

- 1) Outdoor lighting must be a "full cutoff light fixture", i.e. a type of fixture with no light emitted above the horizontal and no light dispersion or direct glare to shine above a 90-degree, horizontal plane from the base of the fixture
- 2) All outdoor lighting fixtures shall be designed, installed, located and maintained to avoid glare on to adjacent properties or streets
- 3) All direct illumination shall be kept within the boundaries of the subject property

## C18 Advertising signage

A development application is required for all types of advertising sign (including temporary signs) however, some signage may be exempt development. Refer to *State Environmental Planning Policy (Exempt and Complying Development Codes) 2008* and the *QPRLEP2022*.

Note *State Environmental Planning Policy (Exempt and Complying Development Codes) 2008* prohibits the display of an advertisement (this does not include business or building identification signs) in certain areas including residential areas.

### Signage definitions and locations

The diagram below shows the location of signs and the table provides definitions of signage types.

Figure 15 Location and type of signs

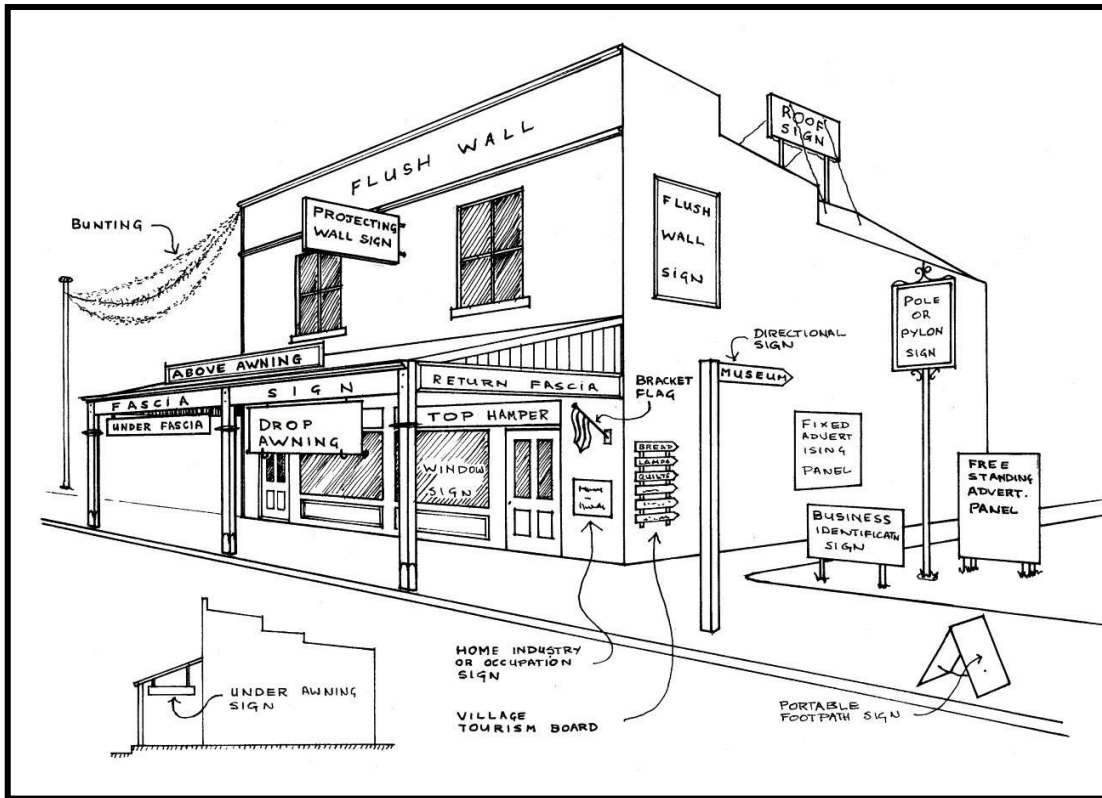

Table 21 Types of signs

Type of Sign	Description
above awning sign	Attached to the top side of an awning (other than the fascia or return end of an awning)
advertisement	Has the same meaning as in the <i>NSW Environmental Planning and Assessment Act 1979</i>
Advertising structure	Has the same meaning as in the <i>NSW Environmental Planning and Assessment Act 1979</i>
bracket style flag sign	Sign or flag suspended from a wall mounted bracket, pole or under awning level
Building identification sign	Has the same meaning as in the <i>Palarang Local Environmental Plan 2014</i>
Bunting	Continuous string of lightweight coloured material and can include a string of flags, decorations etc
business identification sign	Has the same meaning as in the <i>Palarang Local Environmental Plan 2014</i>
cold air balloons and images	Made of materials which permit the sign to be inflated by means of cold air
directional sign	Directing vehicular or pedestrian traffic to a tourist facility or activities or places of historic or scientific interest. This type of sign does not include commercial information
drop awning sign	(Or weather protection blind sign) means a sign displayed on a roll down blind or the like secured to the awning of a building
fascia sign	Means a sign that is either attached to or painted on the fascia or return of an awning
flush wall sign	(Or painted wall sign) means a sign attached to or painted on a wall of a building other than a doorway or display window
pole or pylon sign	Means a sign erected on a single pole or on a pylon which may be free standing or abutting a veranda awning
portable footpath sign	Small free-standing portable advertising structure located on a footpath
projecting wall sign	Attached to the wall of a building or the upper portion of a two storey veranda
real estate sign	Erected on a property indicating that the property is for sale or lease
roadside business sign	Erected in a set designated location for the purpose of directing the travelling public to local business and tourist facilities (may include multiple businesses) where the sign does not relate to activities carried out on the land on which it is erected
roof sign	Advertising panel or structure erected on the roof of a building, or painted thereon
temporary sign	Erected for a limited time period
top hamper sign	Attached to the transom of a doorway or display window of a building
under awning sign	Attached to the underside of an awning (other than fascia or return end)
window sign	Attached to or painted on either side of a shop window
village tourism board	Structure to which multiple directional signs can be attached

## Objective

- a) To ensure that outdoor signage compliments the development on which it is displayed and the character of the surrounding locality
- b) To ensure that outdoor signage does not adversely affect the area in which it is located in terms of appearance, size, illumination, overshadowing or in any other way
- c) To ensure that outdoor signage does not lead to visual clutter through the proliferation of signs
- d) To ensure that the content of signage does not interfere with the amenity of the locality or cause offence to the general public

## Minimum Information requirements for a development application

- A description of the sign in the proposed location including dimensions, colours (including whether it is to be illuminated) and content
- Plans which show the proposed sign(s). Photographs or sketches to illustrate the location of the sign(s) on the building or land should also be included

## Control

### C18.1 All land use zones

- 1) Signage should be designed in sympathy with the needs and character of the building to which it is to be affixed
- 2) Signage should not become the dominant visual element on a building, a group of buildings or a streetscape
- 3) Signs on buildings that are listed as heritage items are to compliment the visual quality of the building and streetscape. The sign is not to adversely impact on the cultural significance of heritage items
- 4) The sign is not to damage or degrade a heritage item
- 5) The content of the sign should be suitable for viewing by people of all ages and backgrounds
- 6) Signs are to relate to land uses in the area in which they are erected
- 7) Except for village tourism/roadside business boards, signs are to be located on the property to which the advertisement relates
- 8) Signs are to be two dimensional and not to include objects
- 9) Signs that relate to multiple businesses should have a co-ordinated approach to colour, font and size
- 10) The font and colour should be distinct from tourist and traffic signs
- 11) The sign is not to over-paint an unpainted heritage item or feature such as tiles or glass
- 12) The sign is to be located so that it does not create a traffic hazard

### C18.2 Business land use zones

- 1) There is to be only one under awning sign per premises per street frontage
- 2) No advertising structure is to extend beyond the vertical projection of the awning
- 3) Signage will be permitted above 3.5 metres in height above natural ground level only where it is designed as part of the building or otherwise sympathetic to the general form and character of the building and the surrounding streetscape
- 4) Advertising structures erected on top of awnings and on roof tops will only be permitted where alternative forms of above awning advertising are not capable of being provided on the building façade and where the size, shape and scale of the advertising is sympathetic to the general form and character of the building and the surrounding streetscape and skyline
- 5) Windows above the awnings of a premise are not to be covered by a wall sign or painted for the purpose of advertising

## C18.3 Specific sign types

### C18.3.1 Business Identification Sign

- 1) The sign is not to exceed 2.5m<sup>2</sup> in area
- 2) The sign should not be internally illuminated unless night time or emergency services are provided

### C18.3.2 Above Awning Sign

Above awning signs and structures can detract from historic streetscapes and are generally considered not to be appropriate for heritage items.

- 1) The sign is to be parallel to the fascia or return end of the awning
- 1) The sign should not project beyond the edge of the awning
- 2) The sign should have a maximum height above the awning of 0.9m to the top of the sign
- 3) The sign is to be a maximum area of 2m<sup>2</sup>

### C18.3.3 Under Awning Sign

- 1) The sign is not to exceed 2.4m in length and 0.4m in height
- 2) The sign is to be erected horizontally to the ground
- 3) The sign is not to be less than 2.6m from the ground
- 4) The sign is not to project beyond the awning
- 5) The sign is to be erected so that the outside edge of the sign is a minimum of 600mm inside the vertical line of the kerb
- 6) The sign is to be securely fixed by metal supports
- 7) If illuminated, the intensity of the illumination and colour of the sign shall remain unchanged while illuminated and there shall be no adverse effect on the amenity of surrounding properties

### C18.3.4 Cold air balloons and images other than toy balloons

- 1) This form of advertising will not be permitted as a permanent form of advertisement
- 2) The device is not to be attached to a heritage item
- 3) The device is not to extend beyond the boundaries of the site
- 4) The device is to be securely attached which is fixed to the ground. Details of the securing are to be submitted with the development application
- 5) The maximum height of the device is to be 6 metres

### C18.3.5 Directional sign

- 1) The sign is not to include commercial information other than the name and distance of the facility
- 2) The sign is to be no more than 0.4 wide (high) and 1 metre in length, or a maximum of 0.4 square metres in area

### C18.3.6 Fascia Sign

- 1) The sign is not to project above or below the fascia or return end of the awning to which it is attached
- 2) The sign is to be wholly contained within the fascia or return end of the awning
- 3) The sign is not to be internally illuminated
- 4) If the sign is to be externally illuminated there is to be no adverse effect on the amenity of surrounding properties

### C18.3.7 Flush Wall Sign (or painted wall sign)

- 1) The sign is not to project above the height of the wall to which it is affixed
- 2) The sign is not to obscure or detract from any architectural feature of a building
- 3) The sign is to be no larger than 3m<sup>2</sup>
- 4) The sign is not to be internally illuminated,
- 5) If externally illuminated, the intensity of the illumination and colour of the sign shall remain unchanged while illuminated and there is to be no adverse effect on the amenity of surrounding properties

### C18.3.8 Pole or Pylon Sign

Pole signs, because of their visibility, can detract from historic streetscapes and are therefore not considered appropriate in the vicinity of heritage items.

- 1) The design, colour and appearance, including content, is to be in harmony with the streetscape
- 2) The maximum number of pole or pylon signs shall be one per 50 metres or part thereof street frontage
- 3) All pole or pylon signs are to have a vertical configuration with a maximum area of 1.5 square metres, a maximum overall height of 3.5 metres; and a minimum clearance of 2 metres between the underside of the sign and the finished ground surface

### C18.3.9 Portable footpath sign

- 1) Portable footpath signs are not to exceed 1 metre in height and 0.75 metres in width
- 2) Only one sign will be permitted per business premises
- 3) The location of portable footpath signs is not to interfere with pedestrian movement
- 4) A clear area of 1.8 metres is to be maintained at all times

### C18.3.10 Projecting Wall Sign

- 1) The sign is to be a minimum of 2.6m above the ground
- 2) The sign is to be at right angles to the wall to which it is attached
- 3) The sign is to have a maximum area of 0.5 square metres
- 4) The sign is to project no more than 0.8m beyond the primary wall face to which it is attached
- 5) The sign not be internally illuminated unless night time or emergency services are provided
- 6) If externally illuminated or flood lit the intensity of the illumination and colour of the sign shall remain unchanged while illuminated and there is to be no adverse effect on the amenity of surrounding properties

### C18.3.11 Advertising Panel

- 1) The panel is not to be erected in front of, or block front or side views of a heritage item
- 2) The panel is not to exceed 1.2 metres in length and 1.8 metres in height
- 3) The panel is not to involve more than 1 advertising panel per premise
- 4) The panel is not to be internally illuminated, if externally illuminated the intensity of the illumination and colour of the sign shall remain unchanged while illuminated and there shall be no adverse effect on the amenity of surrounding properties
- 5) Where an advertising panel is erected on the wall of a building it:
  - i. shall not extend laterally beyond the wall
  - ii. shall not project above the top of the wall
  - iii. shall sit flush to the wall face
  - iv. shall not cover any window or architectural projection or feature

### C18.3.11 Roof signs

- 1) Roof signs are not permitted on or within the vicinity of heritage items

### C18.3.12 Top Hamper Sign

- 1) The sign is to be no wider than the window and door above which it is attached
- 2) The sign is not to extend below the head of the doorway or window to which it is attached

### C18.3.13 Under fascia sign

- 1) The sign is to only be installed where veranda awnings are suspended on posts
- 2) The sign is to have a clear separation of at least 100mm from the fascia or either side post
- 3) The sign is to have a maximum depth of 400mm
- 4) The sign is to have a maximum area of 1.5 square meters
- 5) The sign is to have a minimum clearance above ground of 2.6 metres
- 6) The sign is to be centrally located between posts

### C18.3.14 Window Sign

- 1) The sign is not to cover more than 50% of the total area of all shop windows on a premise
- 2) Signs are permitted on street level windows only
- 3) The sign is not to be illuminated
- 4) The sign is not to have an adverse effect on the amenity of surrounding properties

### C18.3.15 Village tourism/roadside business boards

- 1) The sign is not to not have an adverse visual impact on a streetscape or the immediate landscape
- 2) The sign is not to block or obscure views of heritage items
- 3) The sign is not to impede pedestrian access

## C19 Directional signage

Directional signage advises road users of the direction to facilities which are located on side streets. The function of such signage is directional and informative only and is not for promotion or general advertising.

The number of facilities which can be effectively signposted at any one point must be limited; a proliferation of signage, together with a street name sign, can render all of the signs ineffective as motorists will have difficulty scanning all the information and making decisions within the time available.

Under Council's planning controls *directional sign means any sign directing vehicular or pedestrian traffic to a tourist facility or activities or places of historic or scientific interest. This type of sign does not include commercial information.*

Directional signs erected by Council or another public authority do not require development consent.

Consent is required from Council when erecting directional signage that relates to a commercial facility.

Directional signage for tourist facilities must comply with the Tourist Signposting Manual prepared by Tourism New South Wales and the NSW Roads & Traffic Authority, and be approved by the Tourist Attraction Signposting Assessment Committee (TASAC). This Manual is available at [www.corporate.tourism.nsw.gov.au](http://www.corporate.tourism.nsw.gov.au). TASAC may be contacted through Tourism New South Wales.

## C19.1 Acceptable Directional Signage

The following criteria will be used by Council to determine whether or not to erect a directional sign:

### C19.1.1 The facility subject of the proposed signage

- Facilities for which directional signage may be approved include:
- Civic facilities such as Post Offices, other Government offices, Council administration and services such as libraries, waste management, swimming pools, sports grounds;
- Hospitals
- Public transport facilities such as airport, bus/coach interchanges, railway station
- Tertiary education institutions
- Shopping centres
- Churches and religious institutions.

Council will consider the erection of service signs for commercial facilities only in rural areas. A service sign is a basic description of the service. For example 'Accommodation' not 'Abc Accommodation'. No more than three signs at any intersection will be permitted.

Council may also agree to directional signage for registered charities provided they meet the requirements of this Policy. Requests must be in writing, giving reasons for the request, preferred location and the proposed wording of the sign. Requests should be directed to the General Manager.

As the number of facilities which can be effectively signposted at any one point is limited, the use of community facility name signs should be restricted to facilities which are likely to be those sought by a significant number of visitors to the Queanbeyan-Palerang area.

Primary and secondary schools will only be included if they have some special facilities sought by large numbers of visitors to the Queanbeyan-Palerang area.

As specific facilities are likely to be sought by name, the shortest name by which the facility is commonly known shall be shown on the signs. A denominational name may be included on signs to churches.

Directional signage will only be erected in relation to an activity lawfully carried out. Council will not erect signage to facilities which are prohibited or operating without development consent, if such is required.

### C19.1.2 Shape, size and location

- 1) All proposed signage will be constructed and maintained in accordance with *AS 1742 Series - Manual of Uniform Traffic Control Devices* (relevant version at the time of applying the standards).

### C19.1.3 Visual Amenity

Council wishes to maintain safe and attractive streetscapes which are not dominated by excessive signage that can constitute visual 'clutter'. Such 'clutter' can be distracting to motorists and become a safety hazard. Council may therefore limit the number of directional signs in any one location, may require the amalgamation of individual signage, or require it to be relocated or removed.

Factors to be considered include:

- The size and number of other signage in the vicinity
- The colour, graphics and presentation of the sign. Signs permitted in accordance with this policy will be 'White on Blue'.
- The impact of the sign on the streetscape and heritage value (if any) of the area
- Any potential impact on residential amenity, where relevant
- Potential to cause confusion with traffic signs or controls, or other directional signs
- Patronage of the facility.



Often it is not appreciated by proponents of these signs that there are more effective ways of assisting people to reach their destination, such as providing a clear address, a street directory reference or a map on their stationery or publicity material.

To maintain the effectiveness of community facility signage, the following guidelines shall be used:

- a) Where a community facility abuts a major road, signage other than on the property shall not be provided
- b) Where a community facility abuts a street which runs directly off a major road, no signage should be provided to it unless there may be uncertainty about the direction to take, as may be the case where the street name is the same on both sides of the major road.

### C19.1.4 Costs of signage

Costs associated with erecting, affixing, placing or displaying signs, and removal of redundant signs, are to be the responsibility of the organisation or individual requesting the sign.

### C19.1.5 Removal of directional signage

In accordance with Council's delegation policy, Council Officers shall remove privately erected directional signage which does not have Council's agreement.

Council shall also remove approved directional signage which has become redundant due to the closure or relocation of the facility or which exhibits unsightly or unsafe characteristics. Costs for this work shall be charged to the facility.

## C20 Events

Council encourages the holding of public events as these enhance community wellbeing and contribute to the Queanbeyan-Palerang Regional local government area's economy. However, some events particularly those where there are large numbers of people or changes to traffic arrangements will require consent from Council and possibly State government.

A development application under the NSW *Environmental Planning and Assessment Act 1979* will be required for the majority of events. Events that will require development approval are those that involve; fireworks, animals, a circus, retail and commercial activities, markets, road closures or a street parade, loud noise such as concerts and helicopters or the erection of large structures.

In addition to development approval, consent may be required under Section 68 of the *NSW Local Government Act 1993* for matters relating to waste, camping, toilets, amusement devices and the use of community land (land classified community under the *Local Government Act 1993*).

Events involving the use of roads or footpaths will need to seek approval under the *NSW Roads Act 1993*. Where food or alcohol is to be served there will also be requirements that need to be addressed.

**Note:** Event organisers should discuss the event and requirements with Council at least six months prior to the event as often matters need approval from other government organisations, a committee of Council and the NSW Police

Minimum information requirements for a development application:

The following information is to be provided with the development application or any other approvals sought:

- a detailed description of the event including all activities or forms of entertainment
- a site plan detailing natural features and the layout of event structures and activities
- event location, date(s) and time
- the name of the event organisers
- the number of people and vehicles expected to attend
- the number and type of animals involved (if applicable)

- traffic management and parking
- whether food or alcohol will be allowed or provided
- the management of waste including human waste
- water and power sources (if required)
- security management
- acoustic report (where there the event will generate noise)
- emergency procedures including the evacuation of participants if there is a natural disaster
- public liability insurance details. If the event is to be held on land owned or managed by Council then a minimum of \$20 million will be required

### Objective

- a) To have events which are safe and minimise harm to the natural environment and have a minimal impact on the amenity of an area

## C21 Caravan Parks and camping grounds (including primitive camping grounds)

The *QPRLEP2022* defines caravan parks and camping grounds. The *Local Government (Manufactured Home Estates, Caravan Parks, Camping Grounds and Moveable Dwellings) Regulation 2005* sets out the requirements for a range of situations relating to caravan parks and camping grounds including primitive camping grounds.

### Objective

- a) To ensure that caravan parks and camping grounds to be used by tourists are in a location that will facilitate the tourist experience
- b) To ensure that the amenity of the surrounding area is not impacted by the caravan park or camping ground
- c) To ensure that primitive camping grounds do not impact on the natural environment and are not a hazard to human health

### Control

- 1) Approval must be obtained under Section 68 of the *NSW Local Government Act 1993* in addition development consent under the *NSW Environmental Planning and Assessment Act 1979*
- 2) The development application is to contain the following information:
  - caravan and camping sites (including the size of the site), road layout, parking and access
  - setbacks from buildings and land use activities on adjoining lots
  - building detail including recreation areas and amenity blocks
  - water, wastewater and waste arrangements
  - consideration of environmental matters
- 3) The following is required for primitive camping grounds:
  - drinking water is to be provided
  - provision for the disposal of human waste
  - roads, entrances and parking are to be in accordance with this DCP
  - fire fighting facilities - advice is to be sought from the NSW Rural Fire Service.

Details of facilities are to be included with the development application

## C22 Filling of land

The filling of land whilst having the advantage of using excess soil and creating a usable surface can lead to significant problems if it is not undertaken correctly. For instance the material to fill an area should not be contaminated or contain items such as household goods and bricks that cannot be adequately compacted and may result in further erosion.

The *State Environmental Planning Policy (Exempt and Complying Development Codes) 2008* provides for the minor filling of land. Where development is not exempt in most instances the filling of land will require development approval. The filling of land must fit within in the definition of environmental protection works – refer to the *QPRLEP2022* Dictionary or must be Earthworks in accordance with clause 7.1 of the *QPRLEP2022*.

### Objective

- a) To create an area that will not lead to erosion and sedimentation or public health issues as a result of the leeching of inappropriate fill material

### Minimum information to accompany the development application

- a site plan illustrating the following:
  - the area to be filled and the dimensions
  - waterbodies and drainage lines above and below the fill area
  - the flora and fauna of the area
  - the drainage lines to be altered (if applicable)
  - distance to lot boundaries and the nearest public road
  - the entrance to be used for vehicles bringing in fill
  - the number and type of vehicles to be used for importing the fill and the number of vehicles movements per day
  - the reasons for undertaking the work
  - a description of the soil profile
  - the source, type and amount of fill to be used (cubic metres). Details of the site the fill material is to be taken from (for example current and previous land uses and whether there is a history of the land being or being potentially contaminated) is to be provided. If the soil is considered ‘contaminated’ or ‘previously contaminated’ an auditor’s report will be required. Land use activities that may result in contaminated soil include:
    - railway yards
    - scrap yards
    - service stations
    - sheep and cattle dips

Refer to section B14 Potentially contaminated land of this DCP.

- whether the proposed fill area contains any items of heritage value and whether the site is of Aboriginal significance, refer to section B10 Heritage in this DCP
- a timetable for which the filling will take place and details of the staged compaction of the fill
- a detailed design for retaining walls, ramps, dams and other structures
- the method and rate of compaction
- the means of revegetation of the area including the type of flora species to be planted on the compacted fill area and rehabilitation grass mix, the rate of seeding (eg. kg/ha) and the rate of fertiliser that will be applied to the rehabilitation area
- whether the site is flood prone land, refer to section B9 Flood Planning in this DCP
- sediment and erosion control measures, refer to section B8 Erosion and sediment control in this DCP

## Control

- 1) The fill material is to be compacted to a dry density of not less than 95% Standard Maximum dry density. In some instances Council may require this to be confirmed through compaction testing at an accredited laboratory
- 2) Sediment and erosion control measures are to be established at the commencement of the work, refer to section B8 Erosion and sediment control in this DCP
- 3) Gravel and rock to be used as fill should not be greater than 10mm in size
- 4) The site is to be rehabilitated with both short and long term robust vegetation
- 5) On completion of the landfilling work, written documentation may be required from a registered surveyor stating that the finished levels are in accordance with the approved design is to be submitted to Council

## C23 Demolition of buildings or structures

Clause 2.7 of the *QPRLEP2022* requires that development consent is obtained for the demolition of structures and buildings. In some instances exempt provisions may be applicable, refer to the *State Environmental Planning Policy (Exempt and Complying Development Codes) 2008*.

*Note* Friable asbestos products have been commonly used in commercial and industrial settings since the late 1800s for fireproofing, soundproofing and insulation. Some friable products were also used in houses and may still be found in houses built before 1990. Advice should be sought on the presence and management of asbestos prior to the commencement of any demolition work.

### Objective

- a) To ensure that the demolition of buildings and structures is undertaken in a safe manner
- b) To ensure that demolition waste is disposed of in an environmentally appropriate manner
- c) To ensure that the heritage values of buildings or structures are appropriately managed

### Control

- 1) A development application for the demolition of a building or structure may be part of a development application for a new building. The following information is required:
  - the proposed means of demolition and the safety strategies to be employed including the management of air pollution and noise. This should include the type of machinery to be used and the hours of work. The information should demonstrate how the *Australian Standard 2601-2001 Demolition of Structures* and Workcover requirements will be met
  - a report detailing matters such as underground services, construction materials, the structural support system, the condition of the building or structure, the distance of the building or structure from lot boundaries and other buildings or structures on the lot and adjoining lots
  - a statement outlining any heritage values the building or structure has and how these are to be managed, refer to section B10 Heritage in this DCP
- 2) A Waste Management Plan is to be prepared. The management of hazardous materials including asbestos should be included in the Plan. Refer B.14 Waste Management in this DCP
- 3) A Traffic Control Plan if the demolition will involve restricting access to a public road(s) will be required. Refer to section B7 Engineering requirements in this DCP

### Further information

- *Australian Standard - AS 2601-2001 Demolition of Structures*
- WorkCover Authority of NSW at [www.workcover.nsw.gov.au](http://www.workcover.nsw.gov.au)
- NSW Department of Environment and Heritage relating to information on asbestos at [www.environment.nsw.gov.au/waste/asbestos/index.htm](http://www.environment.nsw.gov.au/waste/asbestos/index.htm)

## C24 Sheds in RU1 Primary Production, C3 Environmental Management and C4 Environmental Living

Sheds include those used for the storing of hay and machinery, shearing sheds, roofs of horse arenas or the like but do not include a dwelling.

Certain sheds and outbuildings may be allowed as exempt development within the RU1 Primary Production and zones. Refer to the *State Environmental Planning Policy (Exempt and Complying Development Codes) 2008*.

Note: Where there is a building envelope on the lot, the provisions of the envelope prevail

### Objective

- a) To ensure farm buildings are designed and sited so as to not detract from the rural landscape, scenic quality and environmental significance of the rural areas
- b) To provide buffers between farm buildings and residential uses

### Control

- 1) Buildings are to be sited to minimise the removal of existing vegetation
- 2) Buildings shall not be sited in a visually prominent location. Refer to C24 Visual impact in rural and environmental land use zones in this DCP
- 3) The highest point of a building must be at least 5m below the highest ridgeline of any hill within 100m of the building
- 4) The maximum height of farm buildings is to be in accordance with *QPRLEP2022 Height of Buildings Map*
- 5) Setbacks are to be in accordance with Table 22 below

Table 22 Setbacks for sheds in E3, E4 and RU1

Setbacks		Minimum Required E3 Environmental Management and E4 Environmental Living zone	Minimum Required RU1 Primary Production and zones
Front	less than 4 hectares	25	25
	greater than 4 hectares	50	50
Side and rear	less than 4 hectares	15	15
	greater than 4 hectares but less than 80 hectares	25	30
	greater than 80 hectares	50	50
Edge of riparian corridor		40	
National park		100	

- 6) On lots less than 16ha sheds shall not exceed 300m<sup>2</sup> (cumulatively) in C3 Environmental Management and C4 Environmental Living land use zones
- 7) The colour of building materials is to be sympathetic to the surrounding environment and buildings

- 8) Materials are to be non-reflective
- 9) Landscaping must be provided where buildings will have a significant impact neighbouring dwellings or roads and the existing vegetation cover does not provide adequate screening. Refer section B12 Landscaping in this DCP for more details

## C25 Rural industry

The *QPRLEP2022* defines rural industry. A development application is required for all types of rural industries. In some instances, it will be necessary to prepare an environmental impact statement. Applicants should contact Council prior to submitting a development application.

Minimum information to accompany the development application

When lodging a development application, the following information is to be provided:

- site analysis as described in Part B1
- a description of the proposed rural industry, including the following:
  - the hours of operation
  - the number of employees
  - the expected noise levels
  - the number of vehicle movements per day
  - the management of waste and waste water
  - the source and amount of water to be used
  - if an agricultural produce industry is to be developed, whether produce will be sold from the property or whether a restaurant or café is intended
- plans of the proposed development including all buildings, open space areas, car parking, loading and unloading areas, entrances and internal roads.
- a landscaping plan detailing the following:
  - any existing vegetation to be retained, relocated or removed
  - paved and grassed areas
  - planting scheme including trees, shrubs, grasses and groundcovers
  - water and maintenance schedules including drip irrigation and mulching details

### Objective

- a) To ensure that industries are compatible with the rural environment
- b) To minimise any adverse impacts on the amenity of surrounding lands

### Control

- 1) Buildings are to be designed and sited so as to not to have a significant impact on the rural landscape, amenity and agricultural productivity of rural areas
- 2) Setbacks are to be in accordance with the table 23.

**Note:** Setbacks may need to be increased in order to address potential environmental or amenity impacts of the proposed development

Table 23 Setbacks for rural industry buildings and storage areas

Setbacks for rural industry buildings and storage areas		Minimum required RU1 Primary Production and zone (metres)	Minimum required IN2 Light Industrial (metres)
Primary road frontage		50	5
Side and rear setback	<4 hectares	15	5
	4ha- 80 hectares	25	-
	> 80 hectares	50	-
Watercourse		100	100
National park		100	-

- 3) Building colours are to be neutral or earth tones and of non-reflective material
- 4) Outdoor storage yards are to be screened from roadways and neighbouring dwellings

## C26 Intensive Agriculture

The *QPRLEP2022* defines intensive livestock agriculture. A development application is required for all types of intensive agriculture. In some instances, it will be necessary to prepare an environmental impact statement. Refer also to *State Environmental Planning Policy (Primary Production) 2021*.

Applicants should contact Council prior to submitting a development application.

### Minimum information to accompany the development application

When lodging a development application, the following information is to be provided:

- site analysis as described in Part B1
- a description of the proposed intensive agriculture development, including the following:
  - the number and type of animals
    - the hours of operation
    - the number of employees
    - the expected noise levels
    - the number of vehicle movements per day
    - the management of waste and waste water
    - the source and amount of water to be used
- plans of the proposed development including all buildings, open space areas, car parking, loading and unloading areas, entrances and internal roads.
- a landscaping plan detailing the following:
  - any existing vegetation to be retained, relocated or removed
  - paved and grassed areas
  - planting scheme including trees, shrubs, grasses and groundcovers
  - water and maintenance schedules including drip irrigation and mulching details

### Objective

- a) To ensure that rural industries are compatible with the rural environment in regard to character and amenity
- b) To minimise any adverse impacts on surrounding lands

- c) To ensure intensive livestock agriculture enterprises are of sufficient size so that potential conflicts with surrounding land is minimised

### Control

- 1) Buildings are to be designed and sited so as to not detract from the rural landscape, amenity and agricultural productivity of rural areas
- 2) Setbacks are to be in accordance with table 24. Note: Setbacks may need to be increased in order to address potential environmental or amenity impacts of the proposed development

**Table 24 Setbacks for intensive agriculture**

Setbacks for rural industry buildings and storage areas		Minimum required RU1 Primary Production and zone (metres)
Primary road frontage		150
Side and rear setback	<4 hectares	150
	4ha- 80 hectares	150
	> 80 hectares	150
Watercourse		100
National park		100

- 3) Building colours are to be neutral or earth tones and of non-reflective material
- 4) Hours of operation may be limited where there is likelihood of adverse impact on the amenity of the surrounding area
- 5) The siting of any building associated with an intensive livestock agricultural enterprise should be below any visually prominent ridgeline or hilltop plateau

## C27 Animal boarding or training establishments for cats, dogs and horses

Animal boarding or training establishments are defined in the *QPRLEP2022*.

**Note:** Animal housing for non-commercial purposes

Where a number of shelters are being developed for cats or dogs for non-commercial purposes a development application will be required. However, in some circumstances the *State Environmental Planning Policy (Exempt and Complying Development Codes 2008)*, for animal shelters may apply.

### Minimum Information requirements for a development application:

- Site analysis as described in Part B1
- Site plan including dimensions of enclosures and associated facilities
- Waste water management plan -For all sites, the location of the appropriately sized effluent management areas must be identified on the plans accompanying the development application
- Maximum number of animals to be housed

### Objective

- a) To provide accommodation, environment and security of animals of a standard which ensures their safety and wellbeing



## Control -General

### C27.1 Water supply

- 1) Facilities must have a continuous water supply, adequate to meet the daily requirements of the animals. An adequate water supply is deemed to be able to meet the needs of drinking water for the animals, cleaning and hosing of shelter at least once a week, and for the washing of animals
- 2) The roof of the facility shall be designed to ensure that roof water is caught and piped to an approved tank. Guttering and down pipes should be provided to convey storm water away from the animal shelter(s)

### C27.2 Facilities

- 1) Facilities must be designed and constructed in a way that provides for the good health and the wellbeing of the animals, which prevents the transmission of infectious disease agents, the escape of animals and does not cause injury to either animals or humans
- 2) Animals must be provided with protection from rain and wind, direct sunlight or other adverse weather conditions and vermin
- 3) Animal housing areas must be provided with ventilation which is sufficient to maintain the health of the animals; while minimising undue draughts, odours and moisture condensation
- 4) Floors of the shelter should be constructed of an impervious material which is graded towards the doorway to permit drainage and with no low spots where urine can collect
- 5) An isolation area must be available at the facility

### C27.3 Security and safety

- 1) The facility must be able to be reasonably secured to prevent access to the facility by unauthorised people
- 2) Any security methods used should allow for ready access to animals and ready exit for staff and animals from the facility in the event of an emergency such as a bush fire

### C27.4 Car Parking

- 1) On-site car parking must be provided in accordance with the *Roads and Traffic Authority Guide to Traffic Generating Development Version 2.2* (or successor documents)
- 2) All parking must be provided in accordance with the *Australian Standard for Parking Facilities 2890*
- 3) On-site car parking shall be constructed and located so as to minimise the noise, light and dust from vehicles entering and leaving the site
- 4) Vehicles are to enter and leave the property in a forward direction

### C27.5 Animal effluent

- 1) Animal effluent is to be treated separately from human effluent. A specific wastewater report for the effluent produced by animals must be provided with the development application. Animal effluent in this instance includes urine, faeces, water used to wash an animal(s) and water used to wash out animal enclosures. Reference should be made to *Designing and Installing On-Site Wastewater Systems* (Sydney Catchment Authority, 2014)
- 2) The effluent management area must be protected from impacts by animals and vehicles by using fencing

### C27.6 Cats

- 1) Cat housing must meet the minimum enclosure sizes shown in Tables 1 and 2 listed in the *Animal Welfare Code of Practice - Breeding Dogs and Cats*

([http://www.dpi.nsw.gov.au/\\_\\_data/assets/pdf\\_file/0004/299803/Breeding-dogs-and-cats-code-of-practice.pdf](http://www.dpi.nsw.gov.au/__data/assets/pdf_file/0004/299803/Breeding-dogs-and-cats-code-of-practice.pdf).) These limits do not apply to cats under veterinary care for a disease or injury

## C27.7 Dogs

- 1) Noise level measurements at the boundary of the property should not exceed 5dBA above existing background noise levels
- 2) Dog housing must meet the minimum enclosure sizes shown in Tables 1 and 2 listed in the *Animal Welfare Code of Practice - Breeding Dogs and Cats* ([http://www.dpi.nsw.gov.au/\\_\\_data/assets/pdf\\_file/0004/299803/Breeding-dogs-and-cats-code-of-practice.pdf](http://www.dpi.nsw.gov.au/__data/assets/pdf_file/0004/299803/Breeding-dogs-and-cats-code-of-practice.pdf).) These limits do not apply to dogs under veterinary care for a disease or injury

## C27.8 Horses

### C27.8.1 Yards

- 1) Size - Day yards or holding yards should be at least 3 m wide and be an area of at least 20 square metres. For working horses, yard size should be increased to 35 square metres. Where a roof or canopy is provided it is to be a maximum height of 4 m from existing ground level
- 2) Yard Surface - The fitting of yards and the type of yard surface should allow drainage (by absorption or evaporation) without ponding

### C27.8.2 Stables

- 1) Size - Minimum stable dimensions should be at least 3.7 m wide and 3.7 m deep. A size of 3.7 m x 4.9 m is preferable. The maximum height is to be 4 m from existing ground level

## C27.9 Management of wastewater

- 1) For proposals that include the staging of events, such as gymkhanas and dressage events, provision must be made for the management of the extra wastewater generated during the event. If the facility is purpose built for the regular staging of events, the wastewater treatment system must have sufficient capacity and the effluent management area must also be correctly sized, taking peak flows into consideration. A balance tank may be required for peak flows

## C27.10 Management of manure

- 1) All manure collected from the stables, tack shed, exercise yard, dressage or indoor arena, or any other area used by the horses, as well as from the manure trap, must be stockpiled in a dedicated, covered area that has a sealed floor. The manure may be mixed with other vegetative material such as used hay, and composted for re-use on the property's paddocks, or sold or otherwise disposed of offsite
- 2) The manure storage area must be located away from areas of concentrated stormwater flow, as well as a minimum of 40 metres from a dam or drainage depression, 100 metres from any perennial or intermittent watercourse and 150 metres from any named river. Any leachate from the manure stockpile is to be diverted away from stormwater structures such as swales, rock-filled trench, earth banks and wetlands using a bund
- 3) All manure management measures must be detailed as part of the water cycle management study, which must take into account any relevant site constraints for the storage and disposal of manure, such as slope and proximity to watercourses

## C28 Horse stables and horse arenas

### C29.1 Horse stables

Horse stables are considered a 'building' under the NSW *Environmental Planning and Assessment Act 1979*. A development application is required for the erection of stables except in circumstances where the *State Environmental Planning Policy (Exempt and Complying Development Codes 2008)*, for animal shelters applies.

If the stables are to be part of an Animal boarding and training establishment then the Animal boarding and training establishment section of this DCP should be consulted.

Minimum Information requirements for a development application:

- Site analysis as described in Part B1
- Site plan including dimensions of enclosures and associated facilities
- Waste water management plan -For all sites, the location of the appropriately sized effluent management areas must be identified on the plans accompanying the development application
- Maximum number of animals to be housed

#### Objective

- a) To provide accommodation, environment and security of animals of a standard which ensures their safety and wellbeing

#### Control

- 1) The minimum stable dimensions should be at least 3.7 m wide and 3.7 m deep. A size of 3.7 m x 4.9 m is preferable. The maximum height is to be 4 m from existing ground level
- 2) Guttering and down pipes should be provided to convey storm water away from the animal shelter(s)
- 3) The stables must be designed, constructed, serviced and maintained in a way that provides for the good health and wellbeing of the animals, which prevents the transmission of infectious disease agents, the escape of animals and does not cause injury to either animals or humans
- 4) Horses must be provided with protection from rain and wind, direct sunlight or other adverse weather conditions and vermin
- 5) The stable(s) areas must be provided with ventilation which is sufficient to maintain the health of the animals; while minimising undue draughts, odours and moisture condensation

#### C28.1.1 Yards

- 1) Size - Day yards or holding yards should be at least 3 m wide and be an area of at least 20 square metres. For working horses, yard size should be increased to 35 square metres. Where a roof or canopy is provided it is to be a maximum height of 4 m from existing ground level
- 2) Yard Surface - The fitting of yards and the type of yard surface should allow drainage (by absorption or evaporation) without ponding

#### C28.1.2 Animal effluent

- 1) Animal effluent is to be treated separately from human effluent. A specific wastewater report for the effluent produced by horses must be provided with the development application. Animal effluent in this instance includes urine, faeces, water used to wash an animal(s) and water used for washing out animal enclosures. Reference should be made to *Designing and Installing On-Site Wastewater Systems (Sydney Catchment Authority, 2014)*
- 2) The effluent management area must be protected from impacts by animals and vehicles by using fencing

### C28.1.3 Management of wastewater

- 1) For proposals that include the staging of events, such as gymkhanas and dressage events, provision must be made for the management of the extra wastewater generated during the event. If the facility is purpose built for the regular staging of events, the wastewater treatment system must have sufficient capacity and the effluent management area must also be correctly sized, taking peak flows into consideration. A balance tank may be required for peak flows

### C28.1.4 Management of manure

- 1) All manure collected from the stables, tack shed, exercise yard, dressage or indoor arena, or any other area used by the horses, as well as from the manure trap, must be stockpiled in a dedicated, covered area that has a sealed floor. The manure may be mixed with other vegetative material such as used hay, and composted for re-use on the property's paddocks, or sold or otherwise disposed of offsite
- 2) The manure storage area must be located away from areas of concentrated stormwater flow, as well as a minimum of 40 metres from a dam or drainage depression, 100 metres from any perennial or intermittent watercourse and 150 metres from any named river. Any leachate from the manure stockpile is to be diverted away from stormwater structures such as swales, rock-filled trench, earth banks and wetlands using a bund
- 3) All manure management measures must be detailed as part of the water cycle management study, which must take into account any relevant site constraints for the storage and disposal of manure, such as slope and proximity to watercourses

## C28.2 Horse arenas

The use of a horse arena must be ancillary to an existing use and does not require development consent. However, the earthworks associated with a horse arena may require development consent if the requirements of Section 2.30 Earthworks and retaining walls under the *State Environmental Planning Policy (Exempt and Complying Development Codes) 2008* cannot be met. If the horse arena is to have a roof a development application for a shed will be required. If the arena is to be part of an Animal boarding and training establishment then refer to section C28 Animal boarding and training establishment in this DCP.

### Minimum Information requirements for a development application

- Site analysis as described in Part B1
- A site plan including the following information:
  - the dimensions of the arena
  - the amount of cut and fill (volume and depth)
  - the treatment of batters
  - whether it will have a roof
  - the base material to be used
  - the management of drainage
  - any associated enclosures and facilities such as lighting
  - setbacks from the lot boundary and watercourses
  - Details of the management of sediment and vegetation
  - Details (location, type and source) of any fill that is to be imported

### Objective

- a) To ensure that the horse arena does not cause a loss of sediment
- b) To ensure that the horse arena maintains the amenity of the area

### Control

- 1) The batters of the arena are to be a minimum of 3 (horizontal):1 (vertical)

- 2) Disturbed areas including batters are to be revegetated as part of the construction process
- 3) A vegetation screen is to be established at the time of construction

## C29 Gates and Fencing

Fences and gates can have a considerable impact on the character of an area. Consideration should be given to height, material, colour and the nature of fencing in the area.

Fencing between lots is a matter for landowners subject to the *NSW Dividing Fences Act 1991*.

*State Environmental Planning Policy (Exempt and Complying Development Codes) 2008* allows some types of fencing as exempt development. Development consent is required if the development standards specified in the *State Environmental Planning Policy (Exempt and Complying Development Codes) 2008* cannot be met.

**Note:** Reference to fencing in this section includes gates.

### Objective

- a) To ensure that stock proof fencing is provided in non-urban land use zones.
- b) To ensure that fencing does not decrease the amenity or character of an area.
- c) To maintain biodiversity by restricting the type of fencing permitted in some circumstances.

### Control

#### C29.1 RU1 Primary Production, C3 Environmental Management and C4 Environmental Living land use zones

- 1) All public road frontages and public open space areas are to be fenced to the following standards:
  - height 1.2 metres (or higher depending on the type of stock, for instance fencing for deer should be higher)
  - strainers - spacing 100 metres to 120 metres depending on terrain
  - steel posts at 6 metre centres
  - steel droppers, one at centre of span between steel posts
  - one 4.0 mm high tensile, high visibility PVC coated wire on top ('horse sighter' or similar)
  - one carry 2.5mm high tensile wire at least 300mm below the top wire
  - one bottom 2.5 mm high tensile wire at least 150mm above the ground
  - 6/70/30 hinged joint netting with each horizontal wire tied to each post and dropper
  - one standard galvanised steel farm gate with steel mesh (minimum 3.65 metres) at an approved entrance
- 2) Post and rail as well as mesh fencing (maximum height 1.2 metres unless required to contain stock) may be considered as an alternative road frontage boundary fence
- 3) Where there are high biodiversity values, controls in this DCP may be varied to maintain biodiversity

#### C29.2 R1 General Residential, R2 Low Density Residential, R5 Large Lot Residential and RU5 Village land use zones

- 1) Front fencing forward of the building line is to be a maximum height of 1.2 metres and behind the building line 1.8 metres in height
- 2) Side and rear boundary fencing is to be to a maximum height of 1.8 metres behind the building line

- 3) Fencing of the street frontage and the side boundary between the front of a building and a street is optional, but shall be no higher than 0.9m
- 4) Fencing materials should be in sympathy with the materials used in the dwelling and the surrounding area
- 5) Where the lot is below the flood planning level, Council should be consulted prior to the erection of the fence
- 6) Rural type boundary fencing not incorporating barbed wire is acceptable for side and rear fences in the existing village area
- 7) Gates are to open inwards
- 8) Zincalume or other reflective materials, electrified or barbed fencing is not permitted and solid steel fences are not permitted forward of the front building line

### **C29.3 Business land use zones**

- 1) Fencing should allow viewing of the development for security purposes. The controls in B5 Crime Prevention through environmental design in this DCP should be considered

### **C29.4 IN2 Light Industrial land use zones**

- 1) Front boundary and side boundaries along a street fencing should allow viewing of the development for security purposes. The controls in B5 Crime Prevention through environmental design in this DCP should be considered. The fence should be constructed so as not to obscure any proposed signage. Concrete blocks are not permitted forward of the building line
- 2) Any fencing that is visible from a public place and located behind the front boundary, is to be finished in materials and colours that are complimentary to the external finish of the building and the streetscape. It is preferable to locate any front boundary fencing behind front boundary landscaping, to reduce the impact on the streetscape

## Part D Area Specific Provisions

The character of a local area comes from a combination of elements including topography, natural features and the expression of historic settlement patterns arising from the purpose of the original town or village in the street layout and features, open spaces and the architecture of individual buildings and their relationship to the street. A new suburb, rural village and an older, well-established suburb all have their own, quite different character. New development may complement the existing character or have such an impact that it alters the character of an area.

Certain areas of the former Palerang local government area have been identified as having a unique character. The sections below describe the history and the current character and desired future character for towns and villages. In some instances, specific controls to protect character have been included in the DCP. Controls may include:

- requirements for a minimum landscaped area
- maximum site coverage
- building style and materials
- front and side setbacks

### Objective

- a) To maintain or enhance the character of an area identified as having a unique character

### Control

- 1) The compatibility of the development with the existing character of an area is to be taken into account
- 2) Where a development is likely to differ to the character described, a statement justifying the proposal against the character statement will be required to be submitted at the same time as the development application

## D1 Bungendore

### D1.1 Character statement

#### Historical background of Bungendore

Bungendore commenced as a rural village to provide services to surrounding properties, a staging post for travellers. The historic nineteenth century area is bounded by Molonglo Street, Rutledge Street, Majara Street and Turallo Terrace.

The grid layout of roads in the original part of the village were gazetted in 1837 and a number of significant commercial and civic buildings were established along Gibraltar Street. Several inns to service travelers were located along the main roads. The Anglican and Catholic churches are within the historic grid and positioned with a block separation. Substantial private houses were established in the period 1850- 1900, many of which survive.

The Rutledge Estate to the east of the railway line was developed in the 1880s at the time of the development of railway and the opening of the rail route from Goulburn to Queanbeyan in 1883. Residential development also extended to the south of Rutledge Street during this period.

In the last fifteen years the Elmslea Estate has been developed to the north of the original village, distinctly separated from the original village by Turallo Creek and reserve. The estate has two parts - project houses on suburban lots on the eastern side and small rural lots to the west. Most recently new suburban style residential development has occurred on the southern edge of the village in the area known as Trucking Yard Lane.

A detailed historical overview is provided in the document *Thematic History Lake George, Molonglo Valley and Burra* by Suzannah Plowman.

## Current character of Bungendore

The village of Bungendore has a strong visual setting on the open plain south of Lake George, bounded by significant ridges to the east, west and south. There is a clear divide between the rural landscape and the town. The village topography is flat and is bisected by Turallo Creek running east – west and the Sydney to Canberra rail line running north - south. The creek and its reserve is the only dominant natural land feature within the village.

Four roads converge on the village, linking it with Braidwood and the south coast, Queanbeyan, Canberra, Goulburn and Sydney. From the east, the Kings Highway (Malbon Street) has views of older dwellings, the cemetery and the new housing development in the northern part of the village. From the south, the Kings Highway includes a mix of heritage buildings and rural commercial suppliers. From the west, Bungendore Road contains views of the rural landscape, the village's sewerage treatment plant and the commercial area. From the north, Tarago Road. Is lined with a belt of native and pine trees. It passes the newer housing estate and crosses over Turallo Creek.

Bungendore is a rural town with commercial, civic and residential neighbourhoods. The characteristic subdivision pattern of the original village and low scale development creates an open, informal and spacious character that contributes to the rural village character. This area is bounded by Molonglo Street, Rutledge Street, Majara Street and Turallo Terrace. There is a clear delineation between the historic nineteenth century village and the late twentieth and twenty first century residential areas.

The small commercial and light industrial areas provide local employment and services to residents in the town and the surrounding rural community. Bungendore accommodates high numbers of tourists – day trippers from Canberra and Queanbeyan, and travellers passing through.

The original village area has four distinct precincts; the civic, commercial, open space areas and the residential area which surrounds the commercial area. The civic area contains numerous significant heritage buildings which continue to serve the functional needs of the village. These include the police station, post office, public school and the railway station. Bungendore Park, well known for its mature pine trees, Anzac memorial and cricket oval, forms the centre of this area. As well as being a sporting facility, it provides a rest stop for visitors and a meeting place for the community. The role of the area has continued to grow with the development of a community health centre and in recent years additional buildings at the school and the new council administrative building.

The commercial area has two distinct parts; the 'tourist' area on Malbon Street and the 'shopping' area on Gibraltar and Ellendon Streets. Unusually for a nineteenth century village, there is not a focal point such as a village square or a 'main' street. The area has many historic buildings some being used for residences and others for business. Most buildings are single storey, constructed with local timber, brick or stone with corrugated steel roofs, either pitched between 25-30 degrees with hips or gables or low slope skillions often concealed behind parapets. There are a few two storey buildings, including the Royal Hotel. A dominant feature of almost every building is a verandah or awning, some forward of, some behind the street boundary line. The newer buildings are generally in sympathy with the character of the village. Materials include brick, painted timber and corrugated steel.

The subdivision pattern in the 'old' part of Bungendore is generally consistent with, and responds to the grid road layout that is oriented east-west. Street blocks are typically square (200 metres by 200 metres), some with service lanes. Original lots were deep and narrow (100 metres by 20 metres). The lots are large, some of the streets have verges without kerbs and those in the inner area have upright kerbs. There has been some change to the shape of the lots over time through amalgamation and subdivision. Lots front the road and buildings are typically oriented to the street.

Historic buildings of the mid nineteenth century village are substantial stone and brick structures. Many of the buildings are important as heritage features in their own right or for their historic stylised contribution to the streetscape. They include places with plain Georgian frontages and modest cottages with verandahs, steeply gabled roofs or other features. Buildings are predominantly single storey. Residences with heritage values are scattered throughout the village. Turallo Terrace on the northern edge of the original village area has a concentration of historic buildings. The churches, important for their rustic gothic style are notable heritage features of the village.



Residential lots are characterised by single dwellings with the front of the dwelling facing the front of the lot (the street frontage) and the rear of the dwelling and the rear yard facing and adjacent to the rear of the lot. Houses are generally set back from the street (average 7 metres) and are generally located within the front half of the lot leaving significant rear yards. Many lots and the streets are planted with mature trees that have created a significant canopy. The planting of mature trees along lot boundaries provides substantial buffers between lots.

The vacant rear yards and significant amount of unbuilt upon area allow for the growth of large canopy trees, which are prevalent high above rooftops. Trees are a mix of evergreen and deciduous so that there is a constant view of the green year round. Existing planting is generally informal with clumps of trees in rear yards and some trees in front yards.

Houses are typically single or double fronted with verandahs and steeply pitched gable or hipped roofs with narrow spans and a high degree of articulation over the floor plan. Wall materials include brick, stone or weatherboard and roofs are predominantly corrugated steel.

There is characteristically a larger proportion of unbuilt on area to built on area, and a larger proportion of soft landscape to hard landscape (such as concrete and paving), that creates a feeling of openness and rural village character. The significant gaps between buildings allow for views through to the surrounding rural landscape.

The major landscape within the village is trees and spaces consisting of the Turrallo Creek reserve, Frogs Hollow, Bungendore Park and the Bungendore cemetery.

The eastern part of Bungendore is largely formed by the Rutledge Estate. This area contains several individually listed places dating from the mid nineteenth century comprising small rural landholdings including farm houses and associated outbuildings. The late nineteenth century street subdivision pattern was laid over the former. There are several early twentieth century dwellings which exhibit characteristics of Californian Bungalow Style. Later development comprises mid twentieth century dwellings of no heritage value.

In recent years, Bungendore has experienced residential growth at the northern and southern ends of the town and some infill development in the older residential areas.

The new dwellings are predominantly single story with some multi-dwellings (town houses) being erected in the inner southern area. The commercial area is undergoing change with dwellings being used for commercial purposes, improvements to existing commercial buildings and the development of a supermarket and a two story building which will contain office and commercial space. These developments are of greater scale, height and bulk than the existing development with very specific functional requirements such as large scale delivery and loading docks and greater parking requirements.

### Desired future characteristics of Bungendore

- Structures are of a low scale with a distinct divide between the town and the surrounding rural landscape
- Development is generally of low density with buildings well separated (except in the commercial area (precinct 2))
- A landscaped setting including mature trees and shrubs, grassed verges and gardens, all of which combine exotic and native species
- The historic grid pattern is intact
- Heritage items are dominant features
- New buildings are of sympathetic form and external materials relate to the existing town character
- Open space areas are not cluttered with new structures

The village of Bungendore is not listed as a heritage conservation area in the *QPRLEP2022* or under the *NSW Heritage Act 1977*. The development controls below aim to maintain and enhance the historic and rural character of Bungendore. The controls relate to development in each of the precincts and are in addition to those listed in B10-Heritage.

## Objective

- To encourage development that is consistent with the desired future character of Bungendore
- To promote a mix of uses and a variety of building styles that enhance and contribute to the character and identity of the precinct and which do not have a detrimental impact of the heritage values of significant prominent buildings and the townscapes.
- To achieve a balance between the functional and aesthetic needs of new development and conserving the historic character of the town

**Precinct: 1** Civic

**Precinct: 2** Gibraltar, Ellendon, Malbon and Molonglo Streets commercial

**Precinct: 3** Historic village residential area

**Precinct: 4** Open Space (Bungendore Park, Turrallo Creek and Frogs Hollow)

Map 1 Bungendore Precincts

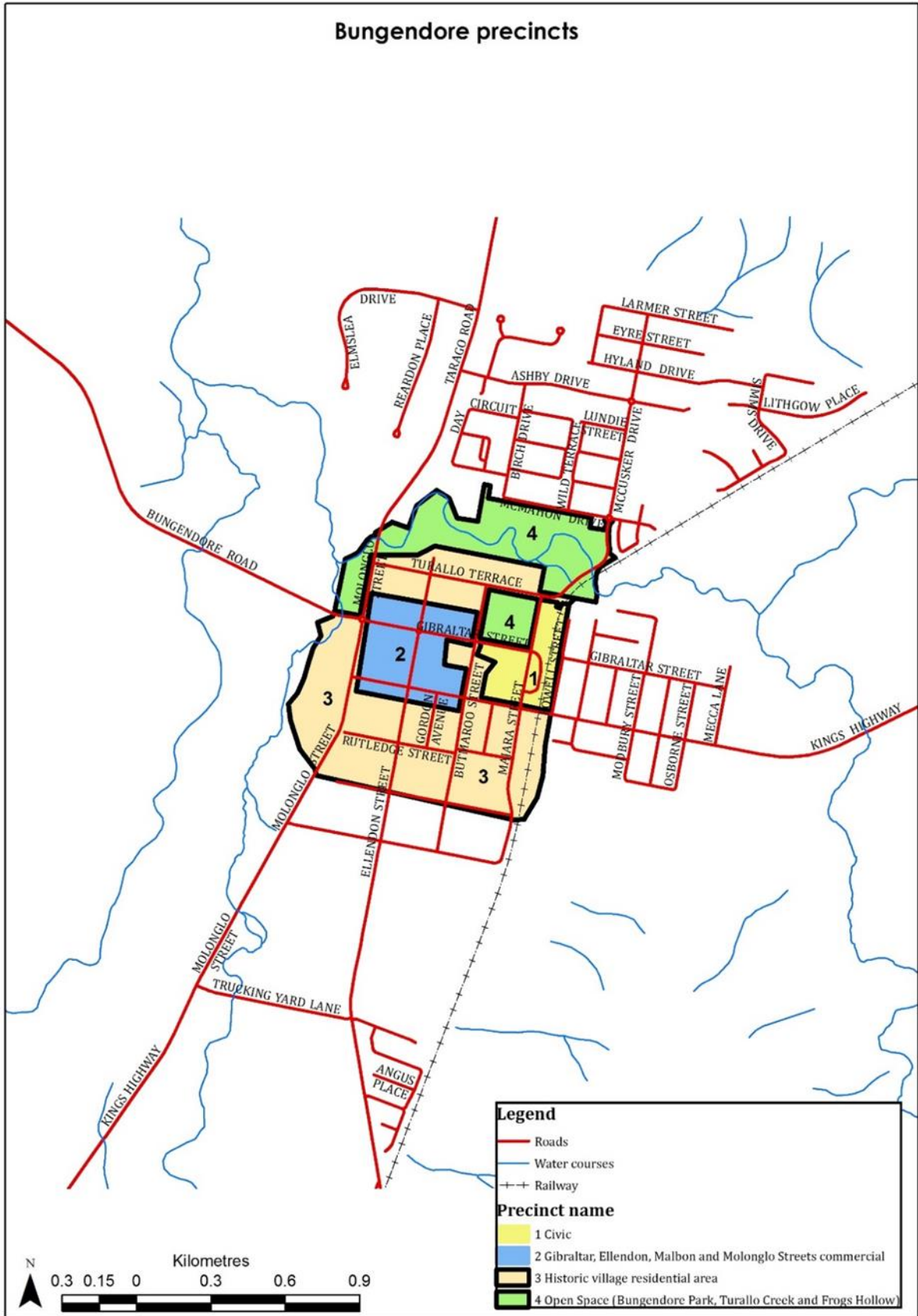

## Precinct 1 Civic

### Current characteristics

- Single story buildings designed and used for public purposes with generous open curtilages
- Buildings face Bungendore park
- A heritage railway complex from the late nineteenth century

### Desired future characteristics

- Heritage buildings including singular civic buildings such as the Railway Station, School of Arts, Police Station and Schoolhouse are dominant features
- Single storey detached buildings with generous open curtilages
- Combinations of materials including stone, brick and weatherboard walls, and corrugated steel, slate or tiled roofs
- Simple gable or hipped roofs of relatively narrow spans and pitches between 25-35 degrees
- Generous landscaped surrounds to buildings
- Variety of front setbacks

### Controls

- 1) Buildings facing the street (or both streets in the instance of a corner lot) shall have openings of a scale and proportion which is sympathetic to the existing historic buildings. Openings should read as being punctuations of the overall wall. The ratio of opening areas should be less than that of the wall area
- 2) Buildings are not to contain large sections of blank walls
- 3) New buildings are to align with the town grid
- 4) Roof planes are to be aligned parallel, or 90 degrees to the side boundary of the lot
- 5) New roofs are to be consistent with historic roof forms. i.e narrow span gables and hips, with a high degree of articulation over the floor plan
- 6) Existing mature trees are to be retained

## Precinct 2 Gibraltar, Ellendon, Malbon and Molonglo Streets commercial

### Current characteristics

- Two distinct areas:
  - the 'tourist' area on Malbon Street
  - the 'shopping' area on Gibraltar and Ellendon Streets
- No focal point such as a village square or a 'main' street
- Mix of residential and commercial historic buildings
- Mostly single storey buildings constructed with local timber, brick or stone with corrugated steel roofs, either pitched between 25-30 degrees with hips or gables or low slope skillions often concealed behind parapets
- Few two storey buildings, the prominent one being the Royal Hotel
- A dominant feature of almost every building is a verandah or awning, some forward of, some behind the street boundary line
- The newer buildings have generally been in sympathy with the character of the village
- Amongst the newer buildings there is no distinct style except that they are single storey. Materials include brick, painted timber and corrugated steel.

### Desired future characteristics

- A mix of styles and building types –commercial, retail and residential use
- A variety of front setbacks, including zero front setbacks for buildings facing the Gibraltar and Malbon Streets
- Front awnings or verandahs

- Combinations of materials including stone, timber, brick and weatherboard walls, and corrugated steel walls and roofs, slate or tiled roofs

### Controls

- 1) Buildings fronting Gibraltar, Malbon or Ellendon streets may have a zero front or side setback
- 2) Buildings fronting Gibraltar, Malbon or Ellendon streets shall incorporate a verandah or awning on the front elevation.
- 3) New buildings are to align with the town grid. Roof planes are to be aligned parallel, or 90 degrees to the side boundary of the lot
- 4) Buildings facing the street (or both streets in the instance of a corner lot) shall have openings of a scale and proportion which is sympathetic to the existing historic buildings. Openings should read as being punctuations of the overall wall. The ratio of opening areas should be less than that of the wall area.
- 5) Buildings are not to contain large sections of blank walls on elevations facing the street. These elevations should be articulated.
- 6) New roofs should be consistent with historic roof forms. i.e narrow span gables and hips, with a high degree of articulation over the floor plan
- 7) Front elevations may incorporate a glazed shopfront. This should not be fully glazed, i.e. full width floor to ceiling but be broken up in traditional proportions with sill, head and transom and have a separately identified entry door
- 8) Verge design should be consistent with adjoining properties, e.g. a combination of brick or concrete paving, timber and soft landscaping and if not fully paved should continue the existing paved footpath alignment.

### Precinct 3 Historic village residential area

#### Current characteristics

- The subdivision pattern is generally consistent with, and responds to the grid road layout that is oriented east-west. There are several service lanes
- The precinct is predominantly residential characterised by single storey dwellings facing the street
- Heritage listed buildings are scattered throughout the precinct but there is a notable concentration in Turallo Terrace on the northern edge of the original village
- The more substantial buildings are generally stone or brick
- Houses are typically single or double fronted with pitched gable or hipped roofs and verandahs. Wall materials include brick, stone or weatherboard and roofs have been predominantly corrugated steel
- Many lots and the streets are planted with mature trees that have created a significant canopy. Planting of mature trees along lot boundaries provides substantial buffers between lots
- The lots are large. Houses are generally set back from the street (average 7 metres) but are generally within the front half of the lot leaving significant rear yards
- There are a variety of verge treatments. Inner streets tend to have formed kerbs. Outer streets have grass or gravel with swales.

#### Desired future characteristics

- Low scale predominantly detached dwellings with generous curtilages and landscaped surrounds
- Simple gable or hipped roofs of relatively narrow spans and pitches between 25-35 degrees with attached awnings and verandahs
- A variety of front setbacks
- Combinations of materials including stone, timber, brick and weatherboard walls, and corrugated steel walls and roofs, slate or tiled roofs

### Controls

- 1) New roofs should be consistent with historic roof forms. i.e narrow span gables and hips, with a high degree of articulation over the floor plan

## Precinct 4 Open Space (Bungendore Park, Turrallo Creek and Frogs Hollow)

### Current characteristics

- Bungendore Park is a town park with semi-formal landscaping surrounded by civic buildings
- Turrallo Creek and Frogs Hollow areas are semi-rural open spaces which provide a green edge to the village.
  - Both have substantial frontage to Turrallo Creek
  - Exotic species are dominant in both, will heavy infestations of willows
- None of the open spaces contain a lot of recreational infrastructure

### Desired future characteristics:

- A mix of native and exotic plantings with few willows
- Limited number of structures
- Open space areas are not 'cluttered' with structures
- Structures are appealing and the design is interesting

### Controls

- 1) Structures are to be of a low scale and have a rural character
- 2) Structures are not to detract from the open landscaped character of the open space
- 3) Development is to be in accordance with the management plans for each of the open space areas

The documents listed below may be of assistance in the design of development within these precincts:

- *Design in Context: Guidelines for Development of Infill Buildings*, NSW Heritage Office
- *Bike Plan and Pedestrian Access and Mobility Plan (PAMP) for Bungendore and Braidwood*
- *Bungendore Park Master Plan*, adopted March 2014
- *Bungendore Heritage Strategy, Palerang Heritage Advisory Committee*, adopted 22 July 2010
- *Bungendore Village Town Centre Concept Plan*, August 2009, dsb Landscape Architects
- *A Landscape Master Plan To Direct The Future Development Of The Village Streetscape Character, 2008, Bungendore Chamber of Commerce and Industry*
- *Bungendore Land Use Strategy and Structure Plan, 2009*, P and A Walsh Consulting Pty Ltd

## D2 Braidwood

Specific provisions for precincts within the State listed heritage conservation area of Braidwood are contained in the Braidwood Development Control Plan (BDCP) 2006.

In respect of the precinct comprising the residential area west of Ryrie Street (Map 2), please refer to the provisions set out below.

Map 2 - Residential Area West of Historic Town Boundary (shown hatched)



## Objective

- a) to preserve and enhance the residential amenity and character of the precinct;
- b) to ensure that development in the vicinity
- c) to conserve historically significant items, views and streetscapes of buildings with historical importance is in harmony with the form and scale of those buildings;
- d) to permit uses other than residential uses only where such uses are compatible with and incidental to the residential use; and
- e) to permit the continuation of existing light industrial use.

## Preferred Land use

- dwelling houses and multi-unit housing
- home offices
- cottage enterprises
- bed and breakfast accommodation

## D3 Villages

### D3.1 Araluen

#### Historical background of Araluen

Gold was discovered in the Araluen valley in 1851. The diggings were very extensive and were divided into six districts. Early on the diggings were often referred to as the Upper and Lower Araluen. The village of Araluen was established in circa 1870. Each district had its own general stores, bakers, shoemakers, blacksmiths, banks, post offices and hotels. There were said to be twenty butchers shops in the valley. Two substantial police stations were built in 1885 to replace earlier buildings including a new court house and lockup. There were several churches, a hospital on 'hospital hill', three public and five private schools. Industry was predominantly gold mining and agriculture. Alluvial mining using sluice boxes and later hydraulic stripping were the dominant means of extracting the gold until dredges were introduced at the beginning of the 20th century and their legacy can be seen on the edges of the village. The 1871 census found that there were over three thousand people (3239) residing in Araluen. As mining declined, residents left the village and the population at the time of the 2011 census was 293 people (ABS) which includes the village and surrounding rural area.

#### Further Information

- Tallaganda Shire Council, 1998, *Development Control Plan No. 1, Environmental Heritage Provisions*
- Further information can be found in the booklet *The History of Araluen* by Lindsay and Roger Thwaites, published by the Braidwood and District Historical Society
- *Braidwood Dear Braidwood*, Netta Ellis, published by NN and NM Ellis, 1989.

#### Current characteristics

The village of Araluen sits within a picturesque cleared wide valley surrounded by steep hills covered with native vegetation, with no development on the steep slopes. The Araluen Creek/Deua River flows through the valley, within which there is a distinct feeling of space and clear views to the surrounding rural landscape. The remains of a large amount of goldmining activity in the valley can still be seen in the riparian areas of the watercourses at each end of the valley. The land use in the valley is now the low density village, orchards and broadscale agriculture.

The village is divided into two parts - a north and south area with approximately half a kilometre of main road connecting the two. There is a mix of housing styles. The majority of new dwellings are small, single storey and of a transportable nature and located in the northern part of the village. There are several buildings throughout the village of heritage significance. This includes the courthouse, churches and the pub. These buildings are of a rural nature and are the remains of a village that was



larger in area and population due to the gold mining. The hall on the main road is the community focal point of the village.

#### Desired future characteristics

- Buildings are of a low scale
- Heritage items are dominant features
- Historic mining features conserved and interpreted

#### Objective

- 1) To encourage development that complements the rural character of the village of Araluen

## D3.2 Captains Flat

### Historical background of Captains Flat

The settlement of Captains Flat developed out of a jumble of mining tents and huts. By 1886 it was recognised that a proper town was needed. 200 acres (80ha) of Crown Land was identified and the town gazetted in 1888. It grew to its peak in the 1890s with six general stores and five hotels. It was a rough and rowdy place but three doctors, two dentists, a chemist, a watchmaker and jeweler, three hairdressers, a tailor, a blacksmith, an insurance agent, a school of arts and cordial factory (Pryke, S, nd, 13) gave it some semblance of respectability.

As a result of the mining, the town went through several boom periods. The railway commenced operation in 1939 and Lake George Mines company built houses and infrastructure. In the early 1960s the last mining activity ceased and the railway closed in 1968.

- Pryke, Susan, nd, *Boom to Bust And Back Again*
- Plowman, Suzannah, *Lake George, Molonglo Valley & Burra - Thematic History* Palerang Council, New South Wales

### Current characteristics

The village of Captains Flat lies in a narrow deep valley through which the Molonglo River flows. The three entrances to the village provide interesting gateways to the village with a mix of views which are dominated by the remains of mining, steep topography or native vegetation. The former mining role of the village can be clearly seen through the small workers cottages in the village and the remnants of mining infrastructure at the top of the southern end of the valley and the impacts of mining on the landscape. The steep sides of the valley are covered in native vegetation with no development on the slopes. The original street layout which follows the floor of the valley remains. Workers cottages are the dominant form of housing with some of the lots often being small for a rural settlement at 500 square metres and the front set back being less than ten metres. Foxlow Street, the main street runs north-south forming the spine of the streets. The southern end of Foxlow Street contains the village's commercial and recreational areas. The two story brick Captains Flat hotel is the dominant building of the small commercial area. The village contains a number of heritage buildings including the former post office which is now a residence and the police station which was previously the courthouse. Buildings such as the community hall and the swimming pool have architectural styles typical of twentieth century mining and construction settlements. The meeting place for Captains Flat village activities is the recreation area in the centre of the village and the community hall. The recreation area backs on to the Molonglo River and provides opportunities for both passive and active recreation. Regular markets and sporting events are held at the recreation area.

### Desired future characteristics

- Buildings are of a low scale
- The historic road pattern is intact and street tree planting intact and reinforced
- Heritage mining features and their landscape settings are conserved
- Heritage items are dominant features

## Objective

- a) To encourage development that complements the character of the village of Captains Flat
- b) To maintain the park as a significant feature of the village

## D3.3 Majors Creek

### Historical background of Majors Creek

Majors Creek, originally known as the Village Reserve of Elrington after Major Elrington, was gazetted in 1860. Gold was discovered in October 1851 and the mining of it had a large influence on the village. Some of the land was freehold owned by Roberts and Badgery of Exeter Farm who collected licenses from the miners. While the alluvial gold was harder to find by circa 1870, reef mining revived the Majors Creek economy for another few decades. Five crushing machines were operating by 1871 and in 1889 a chlorination works was built to extract gold from other ores. At the beginning of the 20th century another phase of mining started with dredging in the creek. The population peaked at well over 1000 in the 1860s (including several hundred Chinese at Long Flat) and was listed at 1074 in 1871. In 1901 the population was 611. Dance halls, annual picnics at the recreation ground, and sports were important for the Majors Creek community. At the time of the 2011 census, the population was 220 people (ABS) which includes the surrounding rural area. A church, St Stephens Episcopalian Church was built in stone by mason Peter Rusconi from 1870-72. A post office, police station and several stores were built which served the village and surrounding rural farming communities. A denominational school operated intermittently until 1893. A brick school building was erected in 1889 and operated until the school was closed in 1969.

### Further Information

- Tallaganda Shire Council, 1998, *Development Control Plan No. 1, Environmental Heritage Provisions*

### Current characteristics

Majors Creek village lies on gently undulating country adjacent to Majors Creek. The creek was the focus of gold mining in the nineteenth century and the remains of the activity can be seen today through the mounds of earth from the tailing heaps left around the watercourse and some infrastructure. Whilst much of the land surrounding the village has been cleared there are areas to the west and east that contain large amounts of native vegetation although, some of the vegetation on the western side has been disturbed through mining. There is a feeling of open space as views of farmland and native vegetation can be seen from all parts of the village. The approaches provide a view of a village that is undisturbed by new development. The original street layout remains intact with dwellings being scattered across the layout as the village has declined in size. The streetscape trees are predominantly exotic. The dwellings are a mix of styles and ages with colourbond being a feature of some of the newer dwellings. Older dwellings are generally brick and with large front setbacks of fifteen to twenty metres. The original commercial centre now only contains a historical hotel. The hotel is single storey and with its verandah opening on to the street, it contributes significantly to the village atmosphere. There are several heritage buildings in the village including the old school house, old police station and St Stephens Anglican Church. The church is part of a cultural and recreational precinct on the eastern side of the village. As well as containing the church, the precinct has a Rural Fire Service Shed, community hall and a recreational area. A bi-annual music festival is held in the precinct utilising all the precinct buildings. St Stephens Church is the dominant feature of the precinct and makes a significant contribution to the whole village. It is constructed of local stone and has a uniquely patterned tiled roof.

### Desired future characteristics

- Structures are of a low scale
- The historic grid pattern is intact and street tree planting are intact
- The cultural and recreational precincts are intact
- Heritage items are dominant features
- Historic mining features conserved and interpreted

## Objective

- a) To encourage development that complements the character of the village of Majors Creek

## D3.4 Mongarlowe

### Historical background of Mongarlowe

The village of Mongarlowe developed where Sergeants Point Creek entered the Mongarlowe River and the river could be easily crossed. Gold was discovered in March 1852 and within the month, 233 miners were fossicking in the area. By the 1870s there were several reef mining enterprises as the alluvial gold was now too scarce and expensive to extract except by the Chinese who continued to fossick. At this time there were over 2000 people on the field which covered 30 square miles with outlying settlements at Feagans Creek, Little River, Warrambucca, Tantulean, Meroo. In the gold boom days there were hotels, a police residence erected in 1883, a log lock-up (now located behind the Braidwood Museum), three churches and a Chinese joss house, a school and teacher's residence built in 1868. The school operated until 1917, was reopened and finally closed in 1964. The bridge over the Mongarlowe River at Mongarlowe was constructed in 1894. The Mongarlowe post office operated from 1862 to 1974.

### Further Information

- Tallaganda Shire Council, 1998, *Development Control Plan No. 1, Environmental Heritage Provisions*
- *Mongarlowe and the Little River Goldfields*, Bruce Russell. Edited and designed by Netta Ellis and Penny Kane Ruzicka, 1989, Braidwood and District Historical Society.

### Current characteristics

Mongarlowe is a small village that lies nestled between Mongarlowe River and Sergeant Point Creek. The vegetation surrounding the village is predominantly native trees. The three entrances to the village are all tree lined, with the western entrance requiring the crossing of the Mongarlowe River via a timber bridge with heritage values. The views upstream and downstream from the bridge are unique as the riparian areas of the watercourse have not been disturbed. The original street layout which follows the Mongarlowe River is intact with the village lots being a range of shapes and sizes. The dwellings are a mix of styles including mud brick and predominantly single storey. Several of the former government buildings along the main road of the village such as the school and police station are now residences. Many of the dwellings have large gardens with a substantial front setback. The larger setback provides a sense of space. There are a number of dwellings on large lots and a Rural Fire Service shed just outside of the village. These are part of the broader village area. The Rural Fire Service shed is the only public building in the village and is the focal point for community gatherings. The primary recreation area is beside the bridge on the western side of the village.

### Desired future characteristics

- Buildings are of a low scale
- A landscaped setting including mature trees and shrubs, grassed verges and gardens, all of which combine exotic and native species
- The historic grid pattern is intact
- Heritage items are dominant features
- Historic features conserved and interpreted

## Objective

- a) To encourage development that complements the character of the village of Mongarlowe

## D3.5 Nerriga

### Historical background of Nerriga

Explorations for a road to transport farm produce from Braidwood to Jervis Bay were undertaken in 1839 and 1840. Aboriginal tracks may have been followed or a route taken similar to that used by earlier explorers. While Corang/Nerriga may have its origin following the opening of the 'Wool Road' in 1841 the development of Nerriga occurred following the occurrence of gold mining along the Shoalhaven and Corang Rivers which became increasingly important from the 1870s with the use of hydraulic stripping and sluicing. Agriculture and sawmilling replaced gold mining in the 20th century.

There has been a hotel in Nerriga since 1865. A Post Office operated from 1865 to 1868, and from 1873 to 1981. A general store was operating in the 1870s and in 1904 there was a general store and a butcher in Nerriga. In 1908 the population of Nerriga was 289. A half time school opened in a bark hut in 1868 which became a public school. The 1896 timber building was replaced in 1952 with a new school which closed in 1974. While a Union- Protestant Church existed in the early 1900s, two churches remain, the Church of England Church of the Good Shepherd opened in 1936 and the Roman Catholic St Mary's opened in 1957. A police station and lock up replaced earlier buildings, possibly in 1904. The Progress Association Hall was completed in 1929, replacing the Federal Hall, which had been the venue for all social activities. Sporting events have been held at the Sportsground since the 1920s.

### Further Information

- Tallaganda Shire Council, 1998, *Development Control Plan No. 1, Environmental Heritage Provisions*
- *Nerriga on the Wool Road*, Pam Radowitz, 1990. Nerriga Historical Museum.

### Current characteristics

The hamlet of Nerriga sits on both sides of the Nerriga Road, a regional road between the southern tablelands and Nowra. The surrounding landscape comprises broadscale agriculture and native vegetation. The original layout of the village remains intact although there are few buildings, particularly dwellings. There are several single story buildings constructed from timber which have heritage value including the hotel. The hotel is visually prominent and a meeting point for locals and those passing through. The community hall is the focal point for the community.

### Desired future characteristics

- Buildings are of a low scale
- Heritage items are dominant features

### Objective

- a) To encourage development that complements the character of the village of Nerriga

## D4 Mt Gillamatong

Mt Gillamatong has a high degree of historic and aesthetic landmark significance that is embedded in the undeveloped nature of the upper part of the hill. It contributes to the broader area of 'Braidwood and its setting'. The native vegetation covering the hill is considered to be of high conservation value (refer to the *QPRLEP2022* Biodiversity (Terrestrial) map).

Map 2 Land above 720 metres on Mt Gillamatong

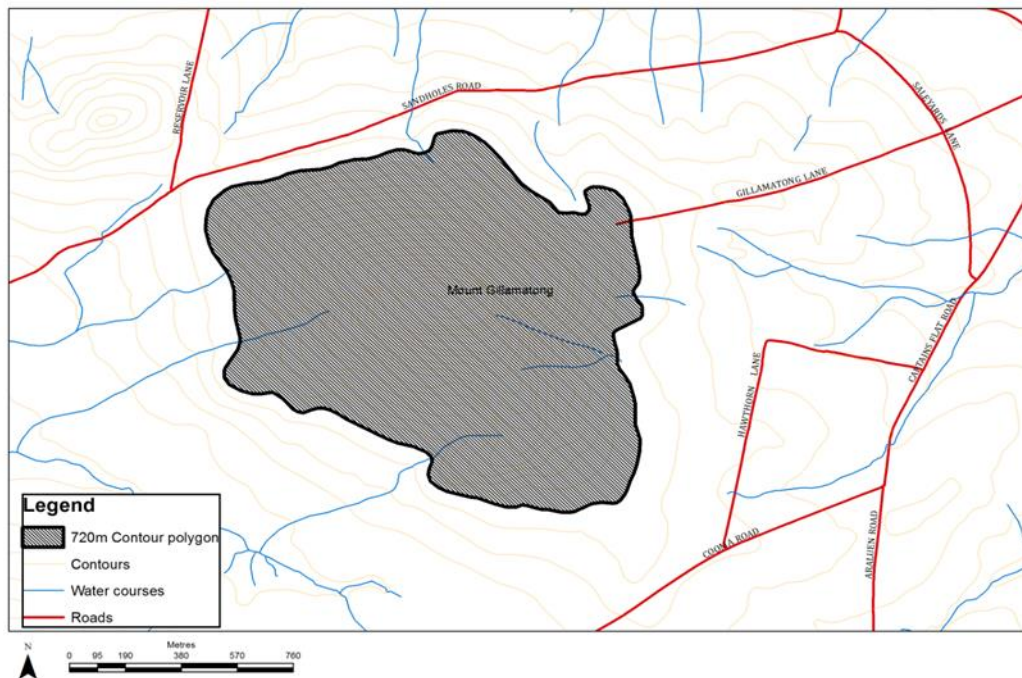

### Objective

- a) To retain the undeveloped character of the upper part of Mt Gillamatong, and to reduce the visual impact of building development on the slopes within the area above 720 metres

### Control

- 1) Where either the whole or part of a development is above the 720 metre contour line, the visual impact of that development on the surrounding area is to be considered

## D5 Lots 1 and 2 DP 456367, Lot 2 DP 131294 and Lot 1 DP 1067259

Lots 1 and 2 SP 456367, Lot 2 DP 131294 and Lot 1 DP 1067259 are adjacent to the Monaro Highway in the locality of Royalla. The *QPRLEP2022* permits residential subdivision with consent.

### Objective

- a) To ensure the view from the Monaro Highway towards Lots 1 and 2 DP 456367, Lot 2 DP 131294 and Lot 1 DP 1067259 is not dominated by buildings

### Control

- 1) A buffer is to be created from tree species indigenous to the Royalla locality on Lot 1 DP 456367. The buffer is to be within 50 metres of the Monaro Highway and for the length of Lot 1 DP 456367. This control is to be undertaken at the commencement of a development approval for residential subdivision of Lots 1 and 2 DP 456367, Lot 2 DP 131294 and Lot 1 DP 1067259
- 2) A landscape plan for each lot created from Lot 1 DP 456367 in C4 Environmental Living is to be submitted with the development application for a dwelling. The landscape plan is to include tree species indigenous to the Royalla locality and encompass the area on the western side of the lot
- 3) Materials and the colour of the materials to be used for the construction of buildings are to be harmonious with the natural environment. Details of the material(s) and colour are to be submitted with the development application

## D6 North Elmslea New Residential Development Areas Identified for Residential Growth under the Bungendore Structure Plan 2048

### Current characteristics

- Forms a rural edge to the village
- Located on the major entry routes into the village

### Desired future characteristics

- Single storey detached dwellings with generous curtilages and landscaped surrounds
- Landscaped gardens, consisting of mature trees and shrubs, provide shade, space and privacy
- The historic grid pattern, generally east-west, is replicated
- Variety of front setbacks
- Generous verges allow for significant street tree planting and non-motorized connections throughout the development.

### Objectives

- a) To encourage development that supports the ‘country feel’ of the village,
- b) To promote the use of verandas, balconies, porches to encourage front yard living spaces for surveillance and to relate to the streetscape and engage with the community.
- c) To ensure that new development is sensitive to the landscape setting and environmental conditions of the locality
- d) To ensure garage structures do not visually dominate the streetscape.

### Controls

- 1) Dwellings are designed and constructed with a combination of materials including local timber, brick or stone with corrugated steel, slate or tiled roofs.
- 2) Dwellings are to be designed with articulated facades to avoid a heavy bulky appearance.
- 3) Dwellings are oriented towards the street.
- 4) Dwellings are single or double fronted with verandahs or awnings and pitched gable or hipped roofs and a high degree of articulation over the floor plan.
- 5) Dwellings are to be setback a minimum 1.5m from side boundaries.
- 6) Dwellings are to be setback a minimum 5.0m from rear boundary.
- 7) Dwellings are to be setback a between 5.0m - 7.0m from the front boundary. Adjoining dwellings are to be offset from one another.
- 8) Garages are to be set back a minimum of 1m behind the front façade of the dwelling

## Part E Notification of Development Applications

Before considering a development application (this excludes complying development applications), Council will notify the proposal in accordance with the QPRC Engagement and Participation Plan adopted 27 November 2019.

# Appendices

## Appendix A - Flood Compatible Materials

BUILDING COMPONENT	FLOOD COMPATIBLE MATERIAL
Flooring and Sub-floor Structure	<ul style="list-style-type: none"> <li>· Concrete slab-on-ground monolith construction.</li> <li>· Suspended reinforced concrete slab.</li> </ul>
Floor Covering	<ul style="list-style-type: none"> <li>· Clay tiles.</li> <li>· Concrete, precast or in situ.</li> <li>· Concrete tiles.</li> <li>· Epoxy, formed-in-place.</li> <li>· Mastic flooring, formed-in-place.</li> <li>· Rubber sheets or tiles with chemical-set adhesives.</li> <li>· Silicone floors formed-in-place.</li> <li>· Vinyl sheets or tiles with chemical-set adhesive.</li> <li>· Ceramic tiles, fixed with mortar or chemical-set adhesive.</li> <li>· Asphalt tiles, fixed with water resistant adhesive.</li> </ul>
Wall Structure	<ul style="list-style-type: none"> <li>· Solid brickwork, blockwork, reinforced, concrete or mass concrete.</li> </ul>
Roofing Structure (for situations where the relevant flood level is above the ceiling)	<ul style="list-style-type: none"> <li>· Reinforced concrete construction.</li> <li>· Galvanised metal construction.</li> </ul>
Doors	<ul style="list-style-type: none"> <li>· Solid panel with water proof adhesives.</li> <li>· Flush door with marine ply filled with closed cell foam.</li> <li>· Painted metal construction.</li> <li>· Aluminium or galvanised steel frame.</li> </ul>
Wall and Ceiling Linings	<ul style="list-style-type: none"> <li>· Fibro-cement board.</li> <li>· Brick, face or glazed.</li> <li>· Clay tile glazed in waterproof mortar.</li> <li>· Concrete.</li> <li>· Concrete block.</li> <li>· Steel with waterproof applications.</li> <li>· Stone, natural solid or veneer, waterproof grout.</li> <li>· Glass blocks.</li> <li>· Glass.</li> <li>· Plastic sheeting or wall with waterproof adhesive.</li> </ul>
Insulation Windows	<ul style="list-style-type: none"> <li>· Foam (closed cell types).</li> <li>· Aluminium frame with stainless steel rollers or similar corrosion and water resistant material.</li> </ul>
Nails, Bolts, Hinges and Fittings	<ul style="list-style-type: none"> <li>· Brass, nylon or stainless steel.</li> <li>· Removable pin hinges.</li> <li>· Hot dipped galvanised steel wire nails or similar</li> </ul>







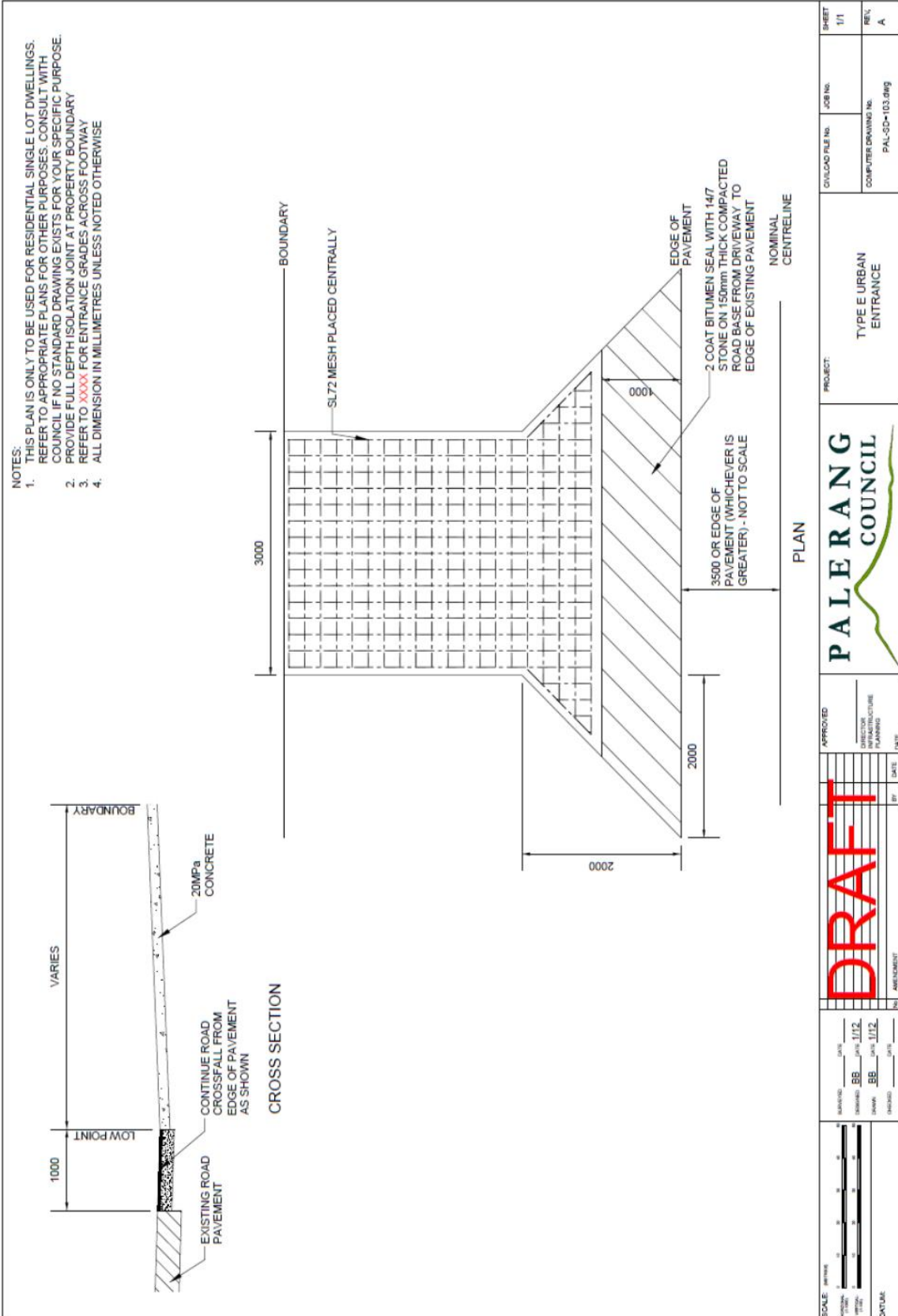







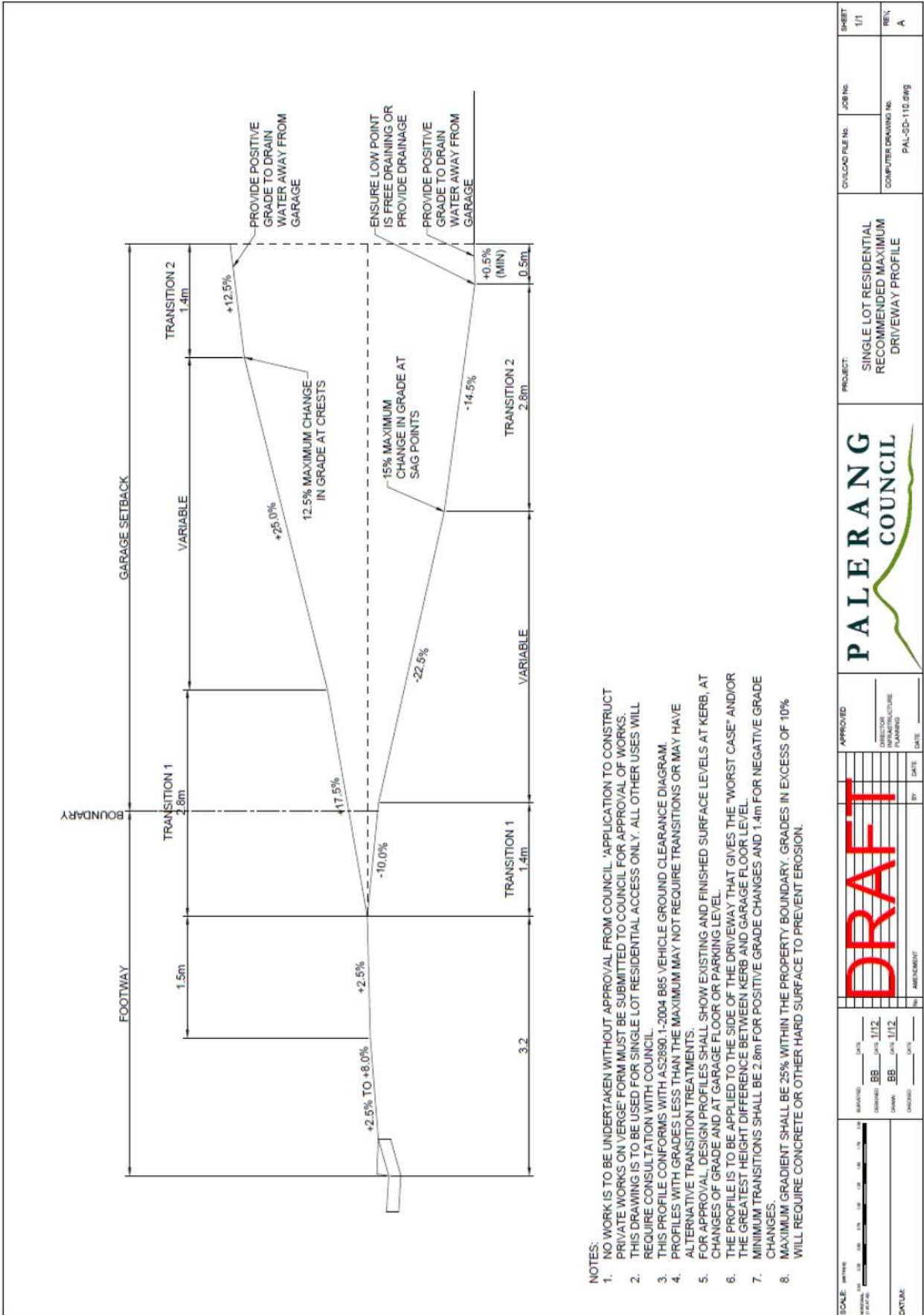

**NOTES:**

- NO WORK IS TO BE UNDERTAKEN WITHOUT APPROVAL FROM COUNCIL. APPLICATION TO CONSTRUCT PRIVATE WORKS ON 'VERGE' FORM MUST BE SUBMITTED TO COUNCIL FOR APPROVAL OF WORKS.
- THIS DRAWING IS TO BE USED FOR SINGLE LOT RESIDENTIAL ACCESS ONLY. ALL OTHER USES WILL REQUIRE CONSULTATION WITH COUNCIL.
- THIS PROFILE CONFORMS WITH AS2890.1-2004 B85 VEHICLE GROUND CLEARANCE DIAGRAM.
- PROFILES WITH GRADES LESS THAN THE MAXIMUM MAY NOT REQUIRE TRANSITIONS OR MAY HAVE ALTERNATIVE TRANSITION TREATMENTS.
- FOR APPROVAL, DESIGN PROFILES SHALL SHOW EXISTING AND FINISHED SURFACE LEVELS AT KERB, AT CHANGES OF GRADE AND AT GARAGE FLOOR OR PARKING LEVEL.
- THE PROFILE IS TO BE APPLIED TO THE SIDE OF THE DRIVEWAY THAT GIVES THE "WORST CASE" AND/OR THE GREATEST HEIGHT DIFFERENCE BETWEEN KERB AND GARAGE FLOOR LEVEL.
- MINIMUM TRANSITIONS SHALL BE 2.8m FOR POSITIVE GRADE CHANGES AND 1.4m FOR NEGATIVE GRADE CHANGES.
- MAXIMUM GRADIENT SHALL BE 25% WITHIN THE PROPERTY BOUNDARY. GRADES IN EXCESS OF 10% WILL REQUIRE CONCRETE OR OTHER HARD SURFACE TO PREVENT EROSION.

SCALE: METRES	DATE: 1/12
0 0.5 1.0 1.5 2.0	DESIGNED BY: BB
	CHECKED BY: BB
	DATE: 1/12
DATE:	BY:
	DATE:
	DATE:

**DRAFT**

APPROVED  
DIRECTOR  
INFRASTRUCTURE  
PLANNING









PROJECT:  
SINGLE LOT RESIDENTIAL  
RECOMMENDED MAXIMUM  
DRIVEWAY PROFILE

C:\LOAD FILE NO.	JOB NO.	SHEET
COMPUTER DRAWING NO.	PAL-DD-110.0WG	1/1
REV.	A	REV.



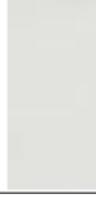

### Appendix C – Suggested Heritage Colours Scheme

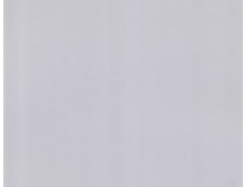
	Walls	Trims 1	Trims 2	Window and door frames	Doors
<b>1. Indian red and buff scheme</b>	Porters Donkey Grey	Dulux Georgian Brick	Porters Burnt Umber	Porters Almond White	Dulux Georgian Brick
					
<b>2. Sandstone and green scheme</b>	Porters Sandstone	Porters Burnt Umber	Porters Chalk NSW	Porters Sage	Dulux Mid Brunswick Green
					
<b>3. Ox Blood scheme</b>	Dulux Ox Blood	Porters Obsidian	Dulux Pale Purple	Porters Cashmere	Dulux Pale Purple
					
<b>4. Charcoal and yellow scheme</b>	Porters Lead	Porters Bellbottoms	Porters Bachiotta Grey	Porters Black Swan	Porters Morocco
					
<b>5. Warm grey scheme</b>	Porters Wild Goose	Porters Uso-Iro	Porters Ice Breaker	Porters Lead	Porters Uso-Iro
					

### Appendix D – Classified Road Map

